

°C

%RH

SHIMADEN

Series **SR107**

SHIMADEN HYBRID RECORDER

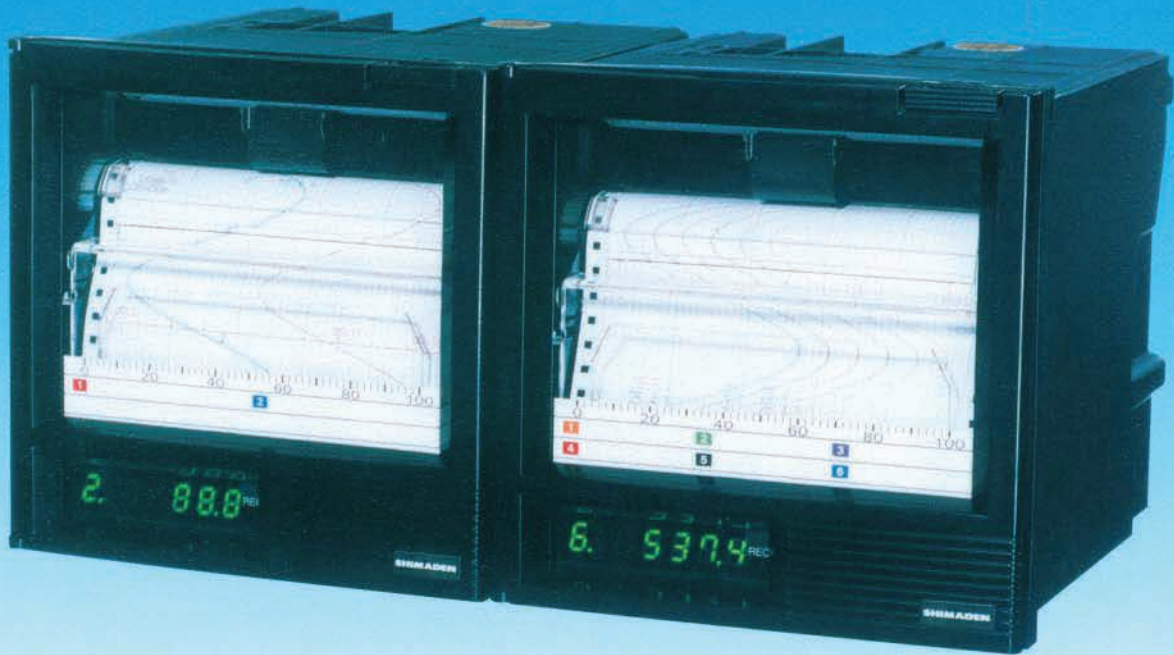

CE approved

The Slimmest and Lightest Recorder in the world

With a Thickness of only 197 (175) mm

Weight: SR107 Continuous Type (1.2Kg)

SR107 Dotting Type (1.5Kg)

BASIC FEATURES

- Compact Housing**
- High-Quality Ink Jet Clear Recording**
- Easy Operation**
- A Variety of Measurements**
- Varied Digital Printing**

SPECIFICATIONS

Indicating, key operation system

- Indication: LED (7 segments) , 6 digits, green
Indication character:
7 segments, alphanumeral
Character height 10mm, width 5mm
- Contents of indication:
Channel No.: 1 digit (1 to 6)
Measured value:
5 digits (including code for measurement below 0)
Temperature: 1 digit below decimal point
Voltage/current:
Scaling, -9999 is displayed for -10000 and under.
Status indication:
Alarm, burnout, carriage failure with symbolic code.
Measurement display cycle:
3 sec for channel selection,
1 sec for data update in the same channel
- Operation key: 3 keys
keylock: soft key lock is possible with key operation.

Input system

- Input points: 1, 2-continuous recording, 6-dot recording
Input signal: Thermocouple, B, R, S, K, E, J, T, N, W, L, U, PN
Resistance bulb, Pt100
DC voltage; 50mV, 500mV, 5V, 50V range
DC current; 4 to 20mA DC, 10 to 50mA
DC (with external resistor, 10Ω)
- Designation of input signal:
Specify when ordering
1-continuous: 1 kind
2-continuous: Up to 2 kinds
6-dot: Up to 2 kinds
- Input range: Specify when ordering
Refer to the attached sheet "Table of input range codes"
1-continuous: 1 kind
2-continuous: Up to 2 kinds
6-dot: Up to 2 kinds
- Measurement cycle:
1, 2-continuous: 0.2sec/point
6-dot: 30sec/all points
- Burnout: When thermocouple or resistance bulb input is disconnected, the recording is deflected to 100%.
- Input filter: Settable within the range of 0-255sec in 1sec steps.
Setting time prior of delivery is 3 sec.

Recording system

- Writing system: Ink jet system, in 6 colors max.
Chart width: 100mm
Chart length: Z fold 15.08m
Recording color:
1-continuous: recording: purple
printing: purple
2-continuous: recording:
No.1 channel, red
No.2 channel, blue
printing: purple
6-dot recording:
No.1 channel, orange
No.2 channel, green
No.3 channel, purple
No.4 channel, red
No.5 channel, black
No.6 channel, blue
printing: black
- Chart speed: 10, 20, 24, 30, 50, 120, 200, 300, 400, 1000, 1200, 1500 mm/h
Can be changed by key operation.
Setting speed prior to delivery is 20mm/h
(Note) in continuous type, it records data intermittently when the speed exceeds 400mm/h.
- Chart speed accuracy: ±0.1% (continuous feed of more than 1m excluding expansion and contraction of paper)
- Recording cycle: Continuous recording:
Depend on chart speed
[Calculation formula]
$$\text{Recording cycle (sec)} = \frac{400}{\text{chart speed (mm/h)}}$$

(not faster than 2 seconds.)
Dot recording: 30 sec/all points.
- Recording range: Specify when ordering
Industrial unit: Specify when ordering
Printing function: [Printing during analog recording]
[Note] Chart speed of continuous type should be less than 400mm/h and that of dotting type should be less than 50mm/h.
- Channel No. printing: Beside of recording line
Periodic printing: Channel number, measurement value, unit, chart speed and lapsed time from the start of recording
[Note] Print period depends on chart speed.
- Scale printing: This print out is effected alternately with periodic printing.

[Note] Print interval depends on chart speed.

Alarm printing: Channel number, kind of alarm and lapsed time from the start of recording when alarm is on or off.

Burnout printing: Channel number and lapsed time from the start of recording

[Printing independent of analog recording]

[Note] Printing is performed by key operation, while analog recording is interrupted. Completion of printing is following by a return to analog recording.

Instantaneous value list: Channel number, measured value, industrial unit, lapsed time from the start of recording

Parameter list (set value list) :
Input signal, input range, recording range, unit, alarm, input filter, chart speed, etc.

Scale line printing: Printing of scale line of any channel

Test pattern: All characters and color patterns can be printed.

[Other printing]

Recording start mark

Chart speed change mark

Alarm

Type: Absolute value alarm, high and low

Setting: Two levels for each channel (high: 2 levels, low: 2 levels, or each level at high / low)

Indication: Alarm level is indicated for each channel at occurrence of alarm.

Printing: Channel No. alarm level and lapsed time from the start of recording are printed on chart paper.

Hysteresis: Approx. 0.2% of recording range

Alarm output: See "Optional specifications"

Performance and characteristics

Indication accuracy/Resolution *1:
Thermocouple input: ($\pm 0.3\%$ + 1digit) of input range

[Note] Not guaranteed at 400°C or less of B thermocouple
:Resolution, 0.1°C
:Minimum input range
See input range table.

Resistance bulb : ($\pm 0.3\%$ + 1digit) of input range
: Resolution, 0.1°C

DC voltage : ($\pm 0.3\%$ + 1digit) of input range
: Resolution, 1 digit minimum

DC current : Converted value to DC voltage guaranteed

Recording accuracy *1:
Indication accuracy $\pm 0.2\%$

Recording resolution:
0.1mm

Reference junction compensation accuracy:
K, E, J, T, N, L, U, PN: $\pm 0.5^\circ\text{C}$
B, R, S, W : $\pm 1^\circ\text{C}$

90% response time:
Less than 2 sec (continuous type only)

Maximum input voltage:
Thermocouple, resistance bulb and DC voltage (50mV, 500mV range) : $\pm 10\text{V}$ DC or less
DC 5V/50V range: $\pm 100\text{V}$ DC or less

Input resistance:
Thermocouple, 50mV voltage range
 $> 10\text{M}\Omega$
5V/50V range: $> 1\text{M}\Omega$
500mV range: $> 100\text{k}\Omega$

Isolation: 100M Ω (between each terminal and earth at 500V DC)
Channel to channel: 500V AC, 1min
Power terminal to ground: 2000V AC, 1min
Input terminal to ground: 500V AC, 1min
Power terminal to input terminal: 2000V AC, 1min
Alarm to alarm: 750V AC, 1min
(leak current: 5mA or less)

Common mode noise rejection:
120dB (50/60Hz)

Series mode noise rejection:
30dB (50/60Hz)

[Note] *1 Measurement condition:
23 $\pm 2^\circ\text{C}$, 65 $\pm 10\%$ RH, power voltage 100 to 120V, 200 to 240V, frequency 50/60Hz within 1%, warm-up time 30min or more, vertical mounting, and free from the effects of vibration, noise, etc.

Power requirement

Line supply: Specify when ordering
Rated voltage
100 to 120VAC or 200 to 240VAC
Usable voltage
85 to 132VAC or 180 to 264VAC

Frequency: 50/60Hz

Power consumption:

- 6-dotting type: 100-120V AC, without option, 13VA or less
- 6-dotting type: 200-240V AC, without option, 13VA or less
- 6-dotting type: 100-120V AC, with alarm, 15VA or less
- 6-dotting type: 200-240V AC, with alarm, 15VA or less

Operating environment

- Temperature limits: 0 to 50°C
- Humidity limits: 20 to 80%RH
(temperature×humidity<3200)

Mounting position:

- Front inclination 0°, rear inclination 30°, left/right inclination 0°

Signal source resistance:

- Thermocouple input: 1kΩ or less
- Resistance bulb input: Less than 10kΩ per line resistance of each wire of 3-wire system should be balanced with others
- Voltage input: Less than 0.1% of input resistance

Vibration: 10 to 60Hz, 0.2m/s² (0.02G) or less

Shock: None

Memory protection: Non-volatile memory

Physical data

- Mounting: Panel (may be inclined up to 30° backwards from the vertical)
Two more records can be mounted side by side.

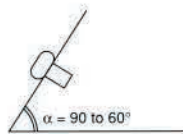

- Panel thickness: 2 to 30mm
- Material: Case: mold Front door frame: mold
- Finish color: Case: black Front door frame: black
- Protective structure:

- Front door: IEC IP50
- Case size: Bezel 144×144mm
- Depth 175mm (Continuous type)
197mm (dotting type)
- Cutout 137×137mm

External terminals:

- Screw terminals (M4 screw)

- Mass: Approx: 1.2kg (continuous type)
Approx: 1.5kg (dotting type)

Optional specifications

- Alarm output (DO):
2, 4 or 6 points N. O contact relay
(refer to ordering information)

- Contact capacity AC 250V/DC 30V 3A (resistance load.)
Alarm output unit is required.

External control input (DI):

- 1 point, no-voltage contact input is used for selection of chart speed in 2 steps. Normally, operation is effected at main chart speed.
Sub-speed is selected with contact ON, and main speed with contact OFF.
Main/sub speed is set by key operation.
When sub-speed is set to 0mm/h, recording start/stop can be selected.
Alarm output unit and external control input unit are required.

Other functions

Printing/recording adjustment:

- Make adjustment when characters kink and/or disturbance of record (round trip difference) occur.

Adjustment of zero/span of analog trend record position:

- The position of ink cartridge is adjusted for correct recording on zero point (0% point) and span point (100% point) on chart paper. This adjustment should be made after replacement of ink cartridge or chart paper.

Measured value shift:

- Indication of recording value is shifted by adding or subtracting calculation of measured value.

Sub chart speed:

- This is for selecting chart speed with external control input. It is selected from the following.
0, 10, 20, 30, 50, 120, 200, 300, 400, 1000, 1200, 1500mm/h
Setting prior to delivery: 20mm/h

Channel skip:

- This is used to stop the operation of unused channel. Skipped channel stops all operations including display and alarm.

Setting recording status at power ON:

- Recording can be started again or disabled when power is ON or when power is recovered from failure.

Applicable standards

- Safety Standards: IEC1010-1 (1990)
 - reinforce insulation
 - overvoltage category II except alarm output terminals (overvoltage category I)
 - pollution degree 2
- EMC Standards: EN50081-1 (1992) , EN50082-1 (1992)
- Dust/drip-proofing: IP50

INPUT	RANGE	CODE	INPUT	RANGE	CODE	INPUT	RANGE	CODE
B	400.0~1400.0°C	210	J	0.0~ 200.0°C	008	Pt100/ JPt100	-50.0 ~ 150.0°C	504
	600.0~1600.0°C	218		0.0~ 300.0°C	009		-50.0 ~ 50.0°C	502
	800.0~1600.0°C	221		0.0~ 400.0°C	010		0.0 ~ 100.0°C	006
R	0.0~1200.0°C	015	T	0.0~ 600.0°C	012		0.0 ~ 200.0°C	008
	0.0~1400.0°C	017		0.0~ 800.0°C	013		0.0 ~ 300.0°C	009
	0.0~1600.0°C	018		100.0~ 300.0°C	202		0.0 ~ 400.0°C	010
	600.0~1200.0°C	217		300.0~ 600.0°C	207		0.0 ~ 500.0°C	011
S	0.0~1400.0°C	017	N	-50.0~ 150.0°C	504		0.0 ~ 600.0°C	012
	0.0~1600.0°C	018		0.0~ 200.0°C	008		100.0 ~ 300.0°C	202
	600.0~1200.0°C	217		0.0~ 300.0°C	009		200.0 ~ 400.0°C	205
	800.0~1600.0°C	221		0.0~ 600.0°C	012		0.00 ~ 10.00	001
K	0.0~ 300.0°C	009	W	0.0~1200.0°C	015		15.00~ 35.00	101
	0.0~ 400.0°C	010		0.0~1600.0°C	018	0.0 ~ 40.0	002	
	0.0~ 500.0°C	011		600.0~1200.0°C	217	0.0 ~ 50.0	003	
	0.0~ 600.0°C	012		L	0.0~ 300.0°C	009	0.0 ~ 60.0	004
	0.0~ 800.0°C	013	0.0~ 600.0°C		012	0.0 ~ 75.0	005	
	0.0~1000.0°C	014	300.0~ 600.0°C		207	0.0 ~ 100.0	006	
	0.0~1200.0°C	015	U		-50.0~ 150.0°C	504	0.0 ~ 150.0	007
	E	0.0~ 300.0°C		009	0.0~ 200.0°C	008	0.0 ~ 300.0	009
0.0~ 400.0°C		010		0.0~ 300.0°C	009	0.0 ~ 400.0	010	
0.0~ 600.0°C		012		PN	0.0~ 300.0°C	009	0.0 ~ 600.0	012
100.0~ 300.0°C		202	0.0~ 600.0°C		012	0.0 ~ 800.0	013	
300.0~ 600.0°C		207	0.0~ 1200.0°C		015	0.0 ~1200.0	015	
			0.0~1200.0°C		015	0.0 ~1600.0	018	

MAXIMUM INPUT RANGE FOR EACH INPUT TYPE

Type of input	Range	
Thermocouple	B 400.0 ~ 1760.0°C	
	R 0.0 ~ 1760.0°C	
	S -200.0 ~ 1760.0°C	
	K -200.0 ~ 1370.0°C	
	E -200.0 ~ 800.0°C	
	J -200.0 ~ 1100.0°C	
	T -200.0 ~ 400.0°C	
	N 0.0 ~ 1300.0°C	
	W 0.0 ~ 1760.0°C	
	L -200.0 ~ 900.0°C	
	U -200.0 ~ 400.0°C	
	PN 0.0 ~ 1300.0°C	
R.T.D	Pt100 -200.0 ~ 600.0°C	
	JPt100 -200.0 ~ 600.0°C	
DC. Voltage	±50mV -50.00 ~ 50.00mV	
	±500mV -500.0 ~ 500.0mV	
	±5V -5.000 ~ 5.000V	
	±50V -50.00 ~ 50.00V	
	Scaling	①Scaling is available within -32767~32767
		②6 digit (including code and decimal point). Decimal point can be set at random.

LEGEND CODE

Legend	Code	Legend	Code	Legend	Code
NON	00	inH ₂ O	20	m/s ²	40
°C	01	mmHg	21	rpm	41
°F	02	cmHg	22	mm	42
%RH	03	inHg	23	cm	43
%	04	l/S	24	m	44
K	05	kg/h	25	mm ³	45
mV	06	kg/cm ²	26	cm ³	46
V	07	kgf/cm ²	27	m ³	47
mA	08	Torr	28	in	48
A	09	mmAg	29	ib	49
W	10	l/min	30	g	50
μs/cm	11	l/h	31	kg	51
mbar	12	m ³ /min	32	t	52
bar	13	m ³ /h	33	l	53
psi	14	Nm ³ /min	34	ppm	54
psi g	15	Nm ³ /h	35	pH	55
Pa	16	mm/s	36	cal	56
kPa	17	m/s	37	kcal	57
mmH ₂ O	18	m/min	38		58
mH ₂ O	19	m/h	39		59

ITEMS	CODE	SPECIFICATIONS
1	SERIES SR107-	Hybrid recorder, DIN 144X144
2	RECORDING SYSTEM	1 Continuous recording
		2 Continuous recording
		6 Dot recording
3	INPUT 1	Select from input type of codes. 4~20mA available with shunt resistor (option)
		Select from measuring range codes
		Select from legend codes
4	INPUT 2 For item 4 [000000] when selecting one input type	Select from input type of codes
		Select from measuring codes
		Select from legend codes
5	POWER SUPPLY	84- 100-120V AC 50/60Hz
		85- 200-240V AC 50/60Hz
6	ALARM OUTPUT/EXTERNAL CONTROL	0 Without
		1 2-point alarm output (only 1 continuous)
		2 4-point alarm output (only 2 continuous)
		3 6-point alarm output (only 6 dotting)
		4 2-point alarm output + external control (only 1 continuous)
		5 4-point alarm output + external control (only 2 continuous)
		6 6-point alarm output + external control (only 6 dotting)
7	REMARKS	0 Without
		9 With (Please consult before ordering)

Up to 2 kinds of input can only be selected for model with 6 dotting recording system.
 ※2 Example—NO.1~NO.3—R.T.D., NO.4~NO.6 K.

■ Standard Range (Factory-set when shipped)

Input	Standard/Rating	Range	Type of input	Range code	Legend code
Termocouple	K	0~1200°C	K	015	01
R.T.D.	Pt100	0~ 200°C	H	008	01
DC Voltage	0~5V DC	0~ 100°C	V	006	00

■ Input Type of Codes

Code	Type of code	Code	Type of code	Code	Type of code	Code	Type of code
B	B. thermocouple	R	R. thermocouple	S	S. thermocouple	K	K. thermocouple
E	E. thermocouple	J	J. thermocouple	T	T. thermocouple	N	N. thermocouple
W	W. thermocouple	L	L. thermocouple	U	U. thermocouple	P	P. thermocouple
G	JPt100	H	Pt100	A	0~10mV DC	M	0~100mV DC
Q	0~1V DC	V	1~5V DC	F	0~10V DC	I	4~20mA DC
0	*INPUT 2 is (0) when select at only INPUT 1						

CODING EXAMPLE

1. SR107-7H00801-000000 84-3C

No.1~No.6

6-dotting type with alarm, Pt100 input (0~200°C range), 20mm/h chart speed, 100~120V 50/60Hz.

2. SR107-7 H00801-K01501 84-0C

No.1~No.3(R.T.D)No.4~No.6(K)

6-dotting type without alarm, Pt100 input (No.1~No.3, 0~200°C range), and K input (No.3~No.6, 0~1200°C range), 20mm/h chart speed, 100~120V AC 50/60HZ.

3. SR107-1 H00801-000000 84-1C

No.1(input)

1-Continuous type with alarm, Pt100 input (0~200°C range), 20mm/h chart speed, 100~120V AC 50/60HZ.

4. SR107-2 H00801-K01501 84-2C

No.1 (input) No.2 (input)

2-Continuous type with alarm, Pt100 input (1st, 0~200°C range), and K input (2nd, 0~1200°C range), 20mm/h chart speed, 100~120V 50/60HZ.

■ Spare and Optional Parts

Items	Type	Remarks
Chart paper (50 divisions)	SRX00DL-5000S	6 charts / box
Recording head	SRZH2002 (PHZH2002)	1,2 continuous
Recording head	SRZH1001 (PHZH1002)	6 dotting
Shunt resistor 10Ω ± 0.1%	SRZT8101	For 4-20mA DC
2-point alarm output	SRZE1101	only 1 continuous
4-point alarm output	SRZE1201	only 2 continuous
6-point alarm output	SRZE0301	only 6 dotting
2-point alarm output + external control	SRZE1A01	only 1 continuous
4-point alarm output + external control	SRZE1B01	only 2 continuous
6-point alarm output + external control	SRZE0C01	only 6 dotting

*4~20mA available with shunt resistor (option)

EXTERNAL DIMENSIONS (I)

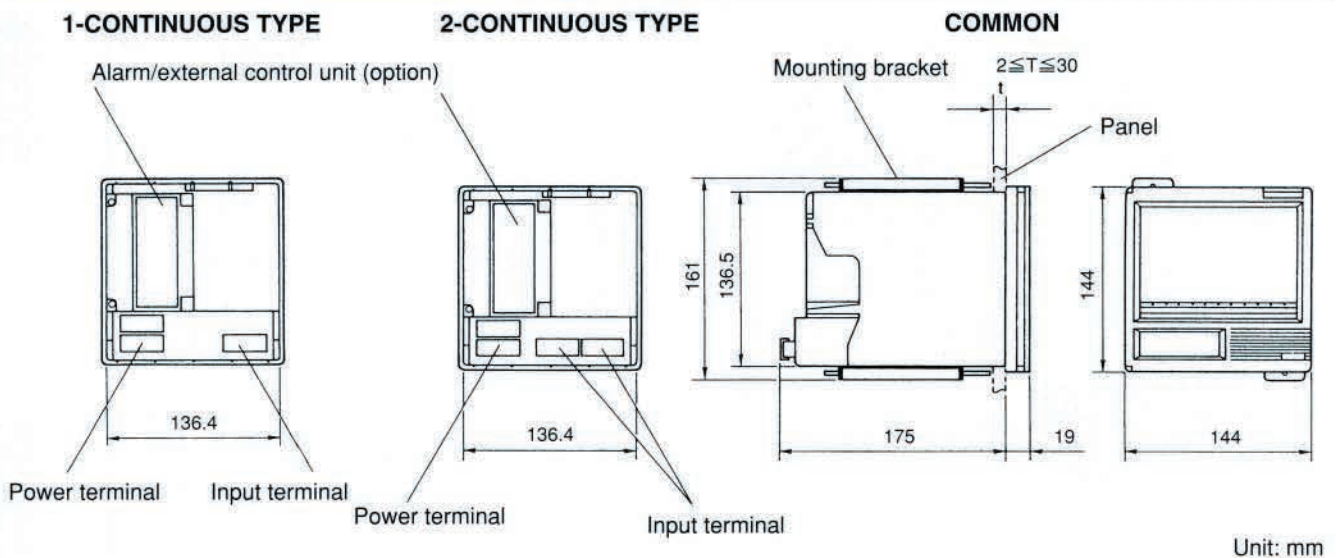

TERMINAL ARRANGEMENT

1-CONTINUOUS TYPE

Power terminal
100 to 120VAC or
200 to 240VAC
50/60Hz



Input terminal

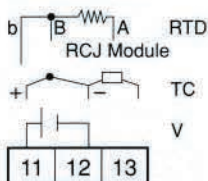

Alarm/External

①①	①②①	Alarm 1
①②	①②②	Alarm 2
①③	①②③	Alarm 3
①④	①②④	Alarm 4
①⑤	①②⑤	Not used
①⑥	①②⑥	Not used
①⑦	①②⑦	Chart speed change
①⑧	①②⑧	Not used
①⑨	①②⑨	Not used

2-CONTINUOUS TYPE

Power terminal
100 to 120VAC or
200 to 240VAC
50/60Hz



Input terminal

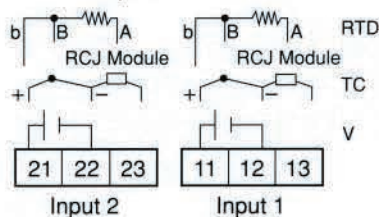

6-DOTTING TYPE

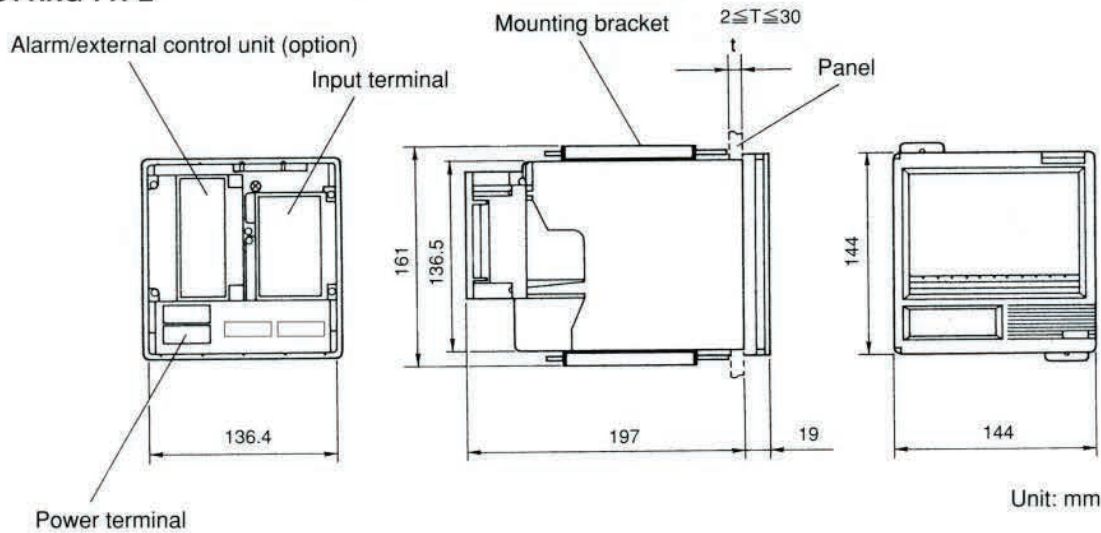

TERMINAL ARRANGEMENT

6-DOTTING TYPE

Power terminal
100 to 120VAC or
200 to 240VAC
50/60Hz



Input terminal

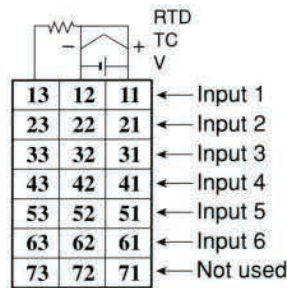

Alarm/External

①①	①②	②①	②②	Alarm 1
①②	①③	②③	②④	Alarm 2
①③	①④	②④	②⑤	Alarm 3
①④	①⑤	②⑤	②⑥	Alarm 4
①⑤	①⑥	②⑥	②⑦	Alarm 5
①⑥	①⑦	②⑦	②⑧	Alarm 6
①⑦	①⑧	②⑧	②⑨	Chart speed change
①⑧	①⑨	②⑨	②⑩	Not used
①⑨	①⑩	②⑩	②⑪	Not used

PANEL CUTOUT

When mounting one unit

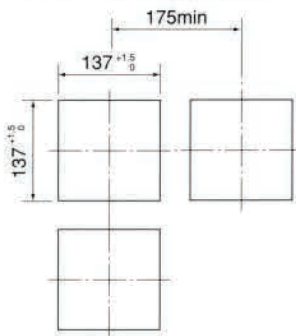

When mounting multiple n unit

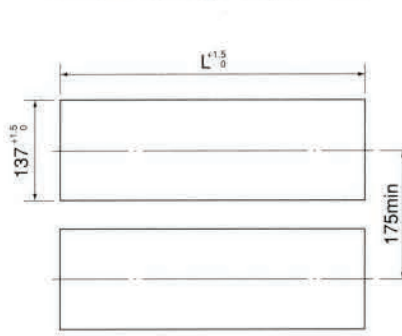

No. of units	L ^{+1.5} ₀ (mm)
2	282
3	426
4	570
5	714
6	858
7	1002
8	1146
9	1290
10	1434
n	(144Xn)-6

Warning

- The SR107 series is designed for the control of temperature, humidity and other physical values of general industrial equipment. (It is not to be used for any purpose which regulates the prevention of serious effects on human life or safety.)

Caution

- If the possibility of loss or damage to your system or property as a result of failure of any part of the process exists, proper safety measures must be made before the instrument is put into use so as to prevent the occurrence of trouble.

(The contents of this brochure are subject to change without notice.)

Temperature and Humidity Control Specialists
SHIMADEN CO., LTD.

Head Office: 2-30-10 Kitamachi, Nerima-Ku, Tokyo 179-0081 Japan
Phone: (03)3931-7891 Fax: (03)3931-3089 E-mail: shima01@blue.ocn.ne.jp