

BR1-27

71 x 97 x 61 mm DIN rail

Clever Split Refrigeration Controller with RTC



Main features

- Up to six real time defrosts per day
- Enhanced ECO Energy Saving management
- Defrost synchronisation between two or more controllers
- Up to 2 auxiliary configurable outputs (Light, switched loads, second evaporator etc.)
- Universal mains power supply
- Connectivity to hard-wired supervisory systems, or wireless option

Applications

Cold stores, control panels.

BR1-27 series

Functions		C1S5W-B
Temperature inputs	Thermostat	•
	Evaporator	•
	Auxiliary	•
DI1, DI2 digital inputs	Voltage free contact / Defrost synchronisation	•
Outputs	Thermostat	•
	Evaporator fans	•
	Defrost	•
	Auxiliary 1	•
	Auxiliary 2	•
Connections	Screw terminals	•
Power supply	100÷240Vac	•
Aux. functions	RS485 serial port	•

› All models come with an alarm buzzer.

› In order to know more options available, please consult LAE or our local dealer.

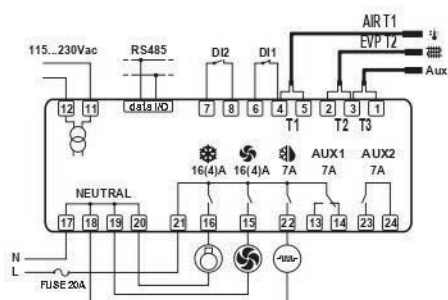

Technical Data

Range	-50÷110°C, -58÷180°F
Resolution	0.1 / 1 °C; °F
Precision	<±0.5°C within the measurement range
Sensor type	NTC10K mod. standard SN4B20P1/P2/P3
Power supply	100÷240Vac ±10% 50÷60Hz 3W
Ambient temperature	-10÷50°C