

# EC150

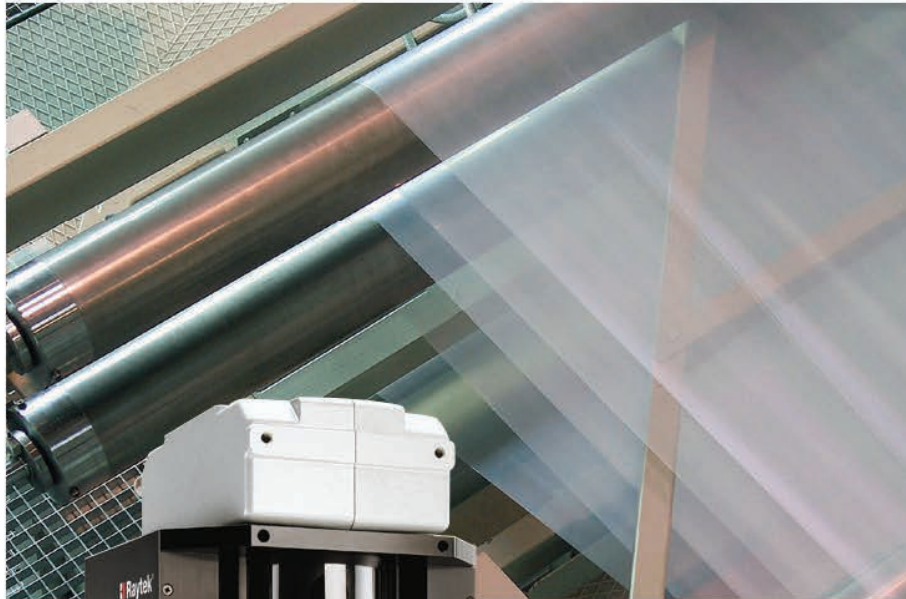

Film Extrusion, Extrusion Coating, and Lamination Processes



MP150 Linescanner

Now available  
with 1024  
datapoints  
per scan!



## Film Extrusion Imaging System

The EC150 System is an automated surface inspection system for detecting, measuring, and classifying defects occurring in extrusion coating, co-extrusion and laminating processes.

### Benefits

- Detect “wavy” or “running” edges, gaps, and torn edges quickly and automatically
- Insure proper web temperatures for strong film-to-substrate adhesion
- Improve profitability and product quality
- Automate quality monitoring
- Reduce scrap

### Features

- View complete thermal images and temperature profiles
- On board Ethernet TCP/IP Communication
- Define product-specific configurations and data files
- Customize and display “automatic” sector overlaid on thermal image
- Built-in line laser sighting
- Automatically analyze sector temperature distributions
- Automatic fail-safe alarm logging
- Software supports English, German, French, Finnish, and Italian languages

## The EC150 Process Imaging System monitors thin film extrusion coating, co-extrusion, or lamination processes

The EC150 System provides a unique capability for managing the quality of plastic film extrusion processes. Temperature and viscosity variations in the melt stream across the width of an extruder flow channel can cause “wavy” or “running” edges, gaps, and edge-tears in the extruded film. Using the MP150 linescanner, the EC150 System continuously monitors the temperature distribution and width of the extruded melt curtain to automatically detect such imperfections.

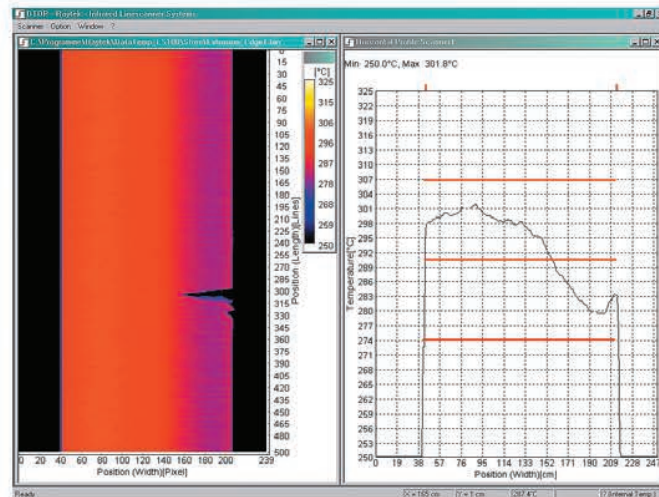

### Temperature Monitoring

The EC150 system continuously monitors the extrusion process allowing temperature data to be visualized as a line graph (profile) and a thermographic image. Profiles and images may be printed or archived for future analysis.

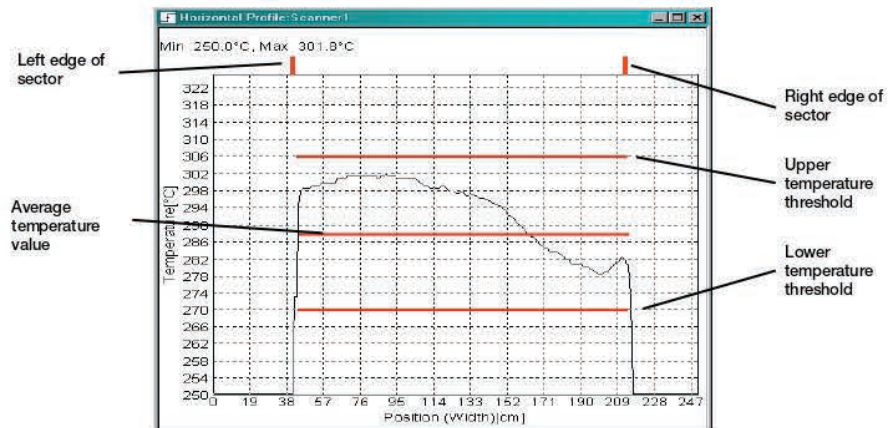

### Automatic Edge Detection

One unique feature of the EC150 is the “automatic sector” feature. Using this capability, the system continuously monitors the melt curtain and automatically “finds” the edges by detecting the temperature difference between the process material and the background. As the edge moves through typical process variations, sectors defined by the user can be programmed to move with it. Temperature deviations representing excessively wavy edges, tears or other defects can be detected from one scanned line of temperature data to the next. If a fault or defect occurs, an alarm may be triggered to facilitate rapid corrective action.

# The EC150 System offers unique capabilities for monitoring film extrusion processes

As illustrated below, the EC150 System continuously monitors the melt curtain temperature distribution to ensure adequate film-to-substrate adhesion and automatically detects edge imperfections such as wavy or running edges, temperature gaps and edge-tears...defects that are otherwise difficult to detect.

## Extrusion Coating

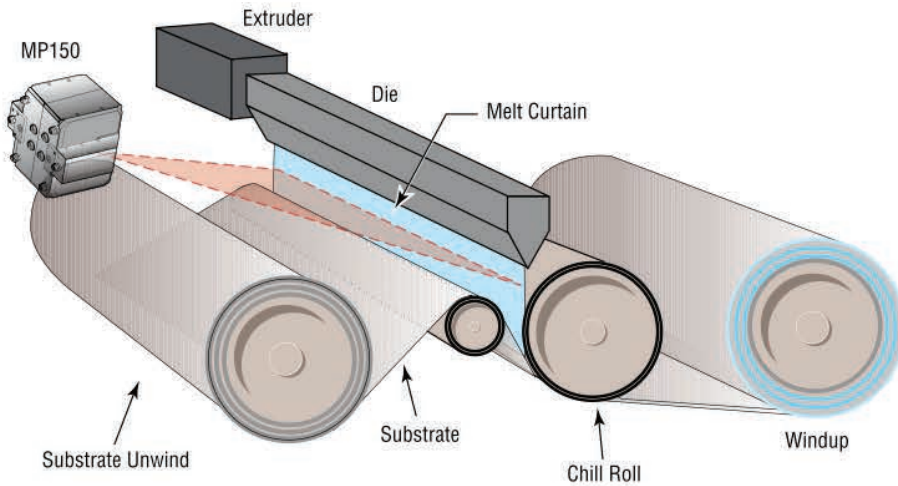

In extrusion coating, resin is melted and formed into thin hot film. The MP150 measures the extruded film as it is coated onto a moving, flat substrate such as paper, paperboard, metal foil, or plastic film. The coated substrate then passes between a set of counter rotating rolls, which press the coating onto the substrate to ensure complete contact and adhesion. The extrusion coated layer may protect a printed substrate or act as a moisture barrier.

## Extrusion Laminating

Extrusion laminating (also known as sandwich laminating) is a process related to extrusion coating, but the extrusion-coated layer is used as an adhesive layer between two or more substrates. A secondary layer is applied to the extrusion coating while it is still hot. The MP150 monitors the melt curtain before the chill roll before the sandwich is formed. The sandwich is then pressed together by pressure rolls. In addition to providing adhesion, the extrusion-coated layer may also serve as a moisture barrier.

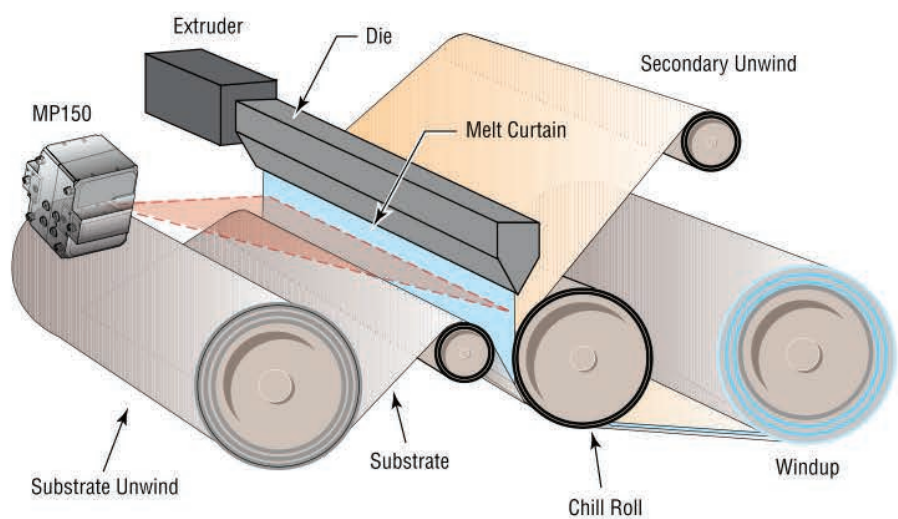

## EC150 System

Part Number	Description
RAYTEC150P30	MP150P30 Process Imager <sup>1</sup> DataTemp EC150 Software
XXXTMP50ACRMB	Adjustable mounting base
XXXTMP50ACPS	Industrial power supply
XXSYS485CV	RS232/485 Converter
XXXTMP50DPB	Alarm/Trigger Box

<sup>1</sup>See MP150 Datasheet for other models.

## EC150 Specifications

Temperature Range <sup>2</sup>	100 to 350°C (212 to 662°F)
System Accuracy <sup>2</sup>	±3°C (±6°F)
Optical Resolution <sup>2</sup>	60:1 (90% energy)
Ambient Temperature	0 to 50°C (32 to 122°F)
Field of View (FOV)	45° or 90° (selectable)
Number of Temp. Points	256 points @ 150Hz 512 points @ 80Hz 1024 points @ 40Hz
Scan Rate	up to 150Hz
Physical Dimensions	200 x 180 x 190 mm (7.9 x 7.1 x 7.5 in)
Weight	7 kg (15.5 lbs)

<sup>2</sup> Specifications for MP150P31 (see MP150 Datasheet for other models). MP150 models available measure from 20°C (68°F) to in excess of 450°C (842°F).

## Options and Accessories

Part Number	Description
XXXTMP50ACCC	MP150 carrying case
XXXTMP50485CB*	RS485 cable extension (10m)
XXXTMP50PSCB*	Power cable extension (10m)

## Easy Installation

The small size of the MP150 linescanner allows for easy installation. The MP150 connects to a standard PC operating Windows® NT4 or Windows® 2000. The system's RS485 digital interface insures reliable operation over long cable runs. The diagram below represents a typical system installation. The Alarm/Trigger Box is part of the EC150 System. This Box provides one Alarm output and includes a "trigger" input (e.g. push-button switch) to momentarily pause the measurement while maintenance is performed on the extruder. The PC never has to be opened to install the EC150 System.

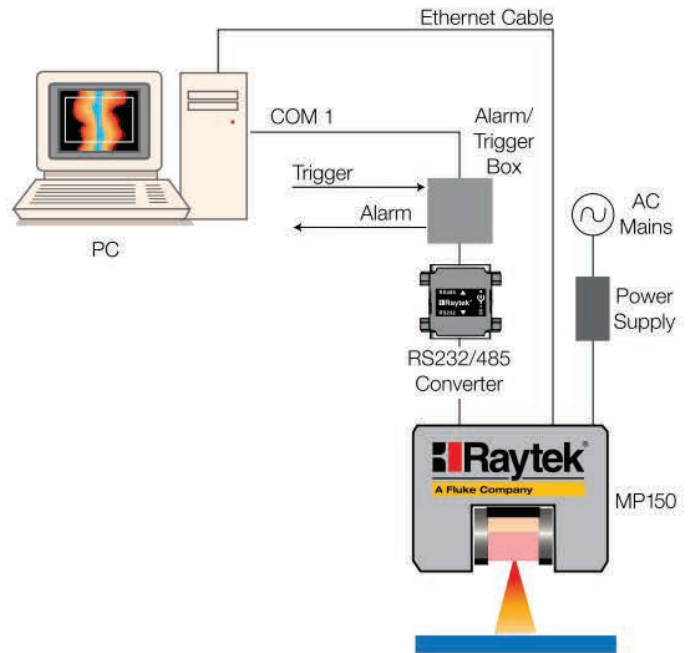

## Fluke Process Instruments

### Americas

Santa Cruz, CA USA  
Tel: +1 800 227 8074 (USA and Canada, only)  
+1 831 458 3900  
[solutions@flukeprocessinstruments.com](mailto:solutions@flukeprocessinstruments.com)

### EMEA

Berlin, Germany  
Tel: +49 30 4 78 00 80  
[info@flukeprocessinstruments.de](mailto:info@flukeprocessinstruments.de)

### China

Beijing, China  
Tel: +8610 6438 4691  
[info@flukeprocessinstruments.cn](mailto:info@flukeprocessinstruments.cn)

### Japan

Tokyo, Japan  
Tel: +81 03 6714 3114  
[info@flukeprocessinstruments.jp](mailto:info@flukeprocessinstruments.jp)

### Asia East and South

India Tel: ++91 22 2920 7691  
Singapore Tel: +65 6799 5578  
[sales.asia@flukeprocessinstruments.com](mailto:sales.asia@flukeprocessinstruments.com)

### Worldwide Service

Fluke Process Instruments offers services, including repair and calibration. For more information, contact your local office.

[www.flukeprocessinstruments.com](http://www.flukeprocessinstruments.com)

© 2016 Fluke Process Instruments  
Specifications subject to change without notice.  
11/2016 3111671D



Raytek is an ISO 9001 certified company