

°C	Series FP23
%RH	
SHIMADEN	

PROGRAMMABLE CONTROLLER



BASIC FEATURES

- 2-channel controller (Basic type: 1-channel controller)**
- Independent 2-loop / 2-input operation control**
- High accuracy $\pm (0.1\% FS + 1 \text{ digit})$**
- High Sampling Cycle 0.1 sec.**
- High resolution 1/1000 °C display achieved**
*Only for R.T.D. input (scale: 0.000~30.000 °C)
- Programmable Max. 400 steps (400 steps x 1 pattern to 20 steps x 20 patterns)**
- Auto-Tuning PID / Expert PID**
- Max. 10 Zone PID control available**
- Independent Universal-Input**
- User Friendly Operation (Menu Driven: 4 Lines LCD Display)**
- Easy Setting & Maintenance via Infrared COM port on the front panel**
- Interface RS-232C/RS-485 (MODBUS / Shimaden)**
- The front dust/splash-proof IP66**
- Universal Power Supply (100~240V AC $\pm 10\%$)**
- Sensor power supply**

COPING WITH ADVANCED PROCESS CONTROL

Temperature °C, Pressure MPa, Flowrate m³/s, etc.

Two types of programs can be executed at the same time.

High-performance programmable controller

FP23 Series



Number of program patterns:

Max. 20

Number of program steps:

Max. 400

High accuracy:

$\pm (0.1\% \text{ FS} + 1 \text{ digit})$

High sampling cycle:

100 msec.

(100 msec. even at 2-loop specification)

Universal-Input

Thermocouple

R.T.D.

DC voltage

DC current

All of them are acceptable.



- * Individual setting is allowed for each channel at 2-loop specification.
- * Current input is executed through externally attached shunt resistor with 250Ω.

Easy setup through infra-red communication



- Easy setting thanks to dedicated setup program
- Reading and writing of various parameters are possible.
- Saving and reading to files are possible.

10-segment linear approximation and square root extraction operation functions

Linearising nonlinear signal input
Number of approximation point:
Max. 11

Linearisation of signals with square characteristic such as flow rate

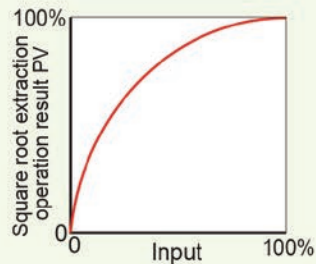
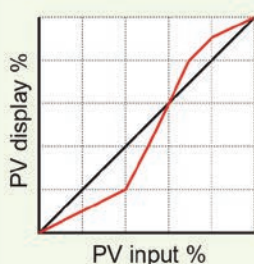

Multiple PID

- Selectable from 10 PID Nos. for each step
- Control by zone PID is also available (Max. 10 zones).

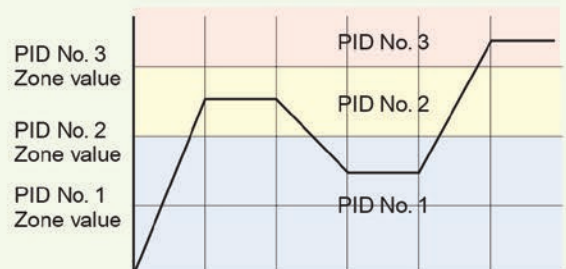

EASY READABILITY AND USABILITY ARE RADICALLY PURSUED.

Excellent visibility thanks to the large LED with 5 digits x 2 lines and LCD with 128 x 32 dots

■PV Display Panel

- Measured value (PV) display
- CH2PV is indicated when CH2 lamp is illuminated.
- Error message display

■SV Display Panel

- Target value (SV) display
- CH2SV is indicated when CH2 lamp is illuminated.
- CH2PV is indicated when PV2 lamp is illuminated.
- Error message display

■LCD Display Panel

- Pattern / Step No. display
- Output display (numerical value and bar graph)
- Channel display
- Various setting parameters display



■Status Lamp Display Panel

- RUN: Program on standby: Flashing
Program in execution: ON
- HLD: Program suspended: ON
- MAN: Manual operation (MAN) in execution: Flashing
During FIX mode: ON
- FIX: Event output being on: ON
- EV1~3: External control output being on: ON
- DO1~5: When start pattern No. by DI is selected: ON
- EXT: In communication mode: ON
- COM: Auto tuning in execution: Flashing
- AT: Control output monitor lamp

■Infra-red Communication Display Panel

- Infra-red communication through dedicated adaptor
- Receptacle/illuminator

■Key Switch Display Panel

- DISP** : Return to the basic screen
: Switching to display mode
- GRP** : Go to screen group
- SCRN** : Go to any screen within the group
: Selection of editing and setting parameters
- ◀▶▲** : Increase/decrease of numeric value and scaling factor
- ENT** : Registration of numeric value and/or data
- STEP** : Switching of step No.
- PTN** : Switching of pattern No.

EASY PARAMETER SETTING THANKS TO THE INTERACTIVE MODE THROUGH 4 LINE LCD DISPLAY

DISPLAY MODE CORRESPONDING TO EACH SPECIFICATION

◆ Independent 2-loop control



- CH1...PV
- CH2...PV
- CH1...PTN No. STEP No. SV
- CH2...PTN No. STEP No. SV

◆ 2-input operation control



- Operation result PV
- SV
- Input 1
- Input 2

◆ Positioning proportional control (servo output)



- PV
- SV
- Opening

COPING WITH MULTIFARIOUS

1 Loop / 2 Loop Control

1-input control

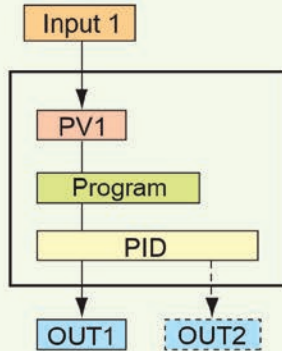

* 1 output (for heating/cooling control) may also be provided.

2-input operation control

(max. value, min. value, deviation value, average value)

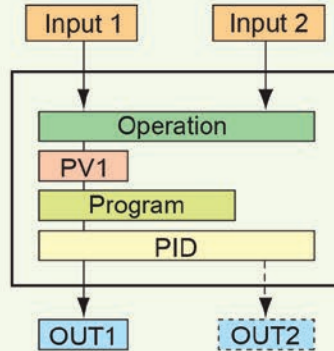

* 2 outputs (for heating/cooling control) may also be provided.

Independent 2-loop control

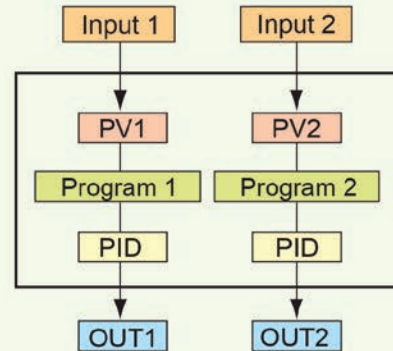

Servo Output Specification (Control motor/motor valve control)

With feedback potentiometer

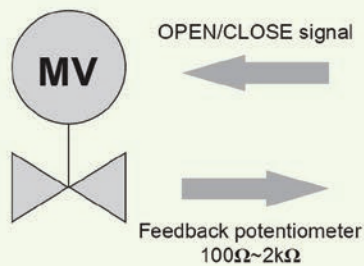

Without feedback potentiometer

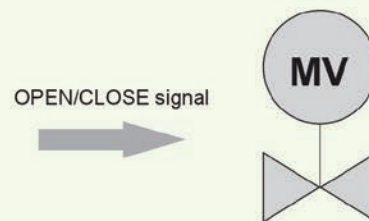

* Proportional control may be executed both with and without feedback potentiometer.

Easily Connectable with External Equipment such as PLC thanks to Abundant Number of Input/Output Points

• External Control Input (DI): Max. 10

Execution/stop of program control
Stop of program control
Suspension of program control
Postponement of program step
FIX mode
Manual control operation
Logical operation input
Selection of start pattern No.



• Event Output: 3 External Control Output: Max. 13

27 alarm actions, various status output and logical operation output

• Sensor power supply 24V DC

• Analog Output: Max. 2

Externally output PV, SV, deviation value, output value, limit value for each channel by means of analog signal

• Communication function

Both Shimaden standard protocol and MODBUS (RTU/ASCII) communication protocol are equipped.

APPLICATIONS

Heating Control

1-input Specification

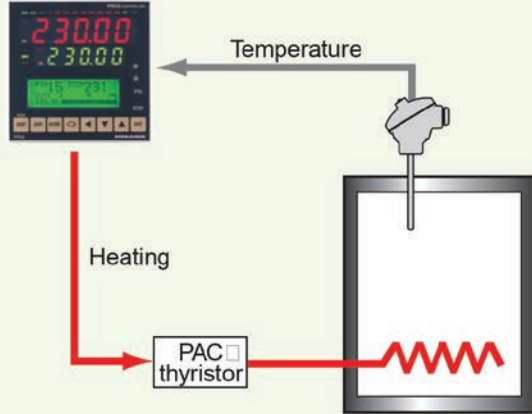

3-Zone Program Temperature Control of Electric Furnace

1-input Specification (Master-slave control)

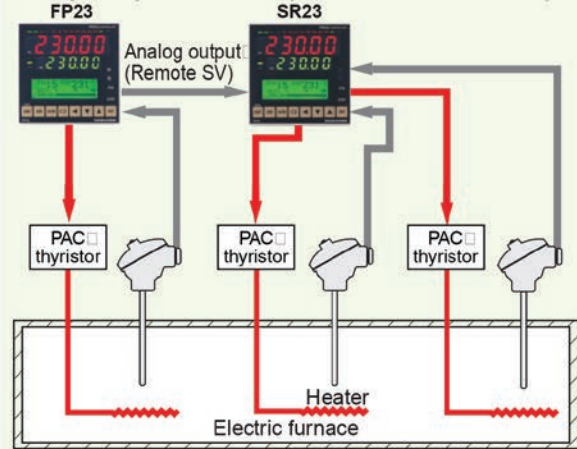

Heating/Cooling Control

1-input Specification

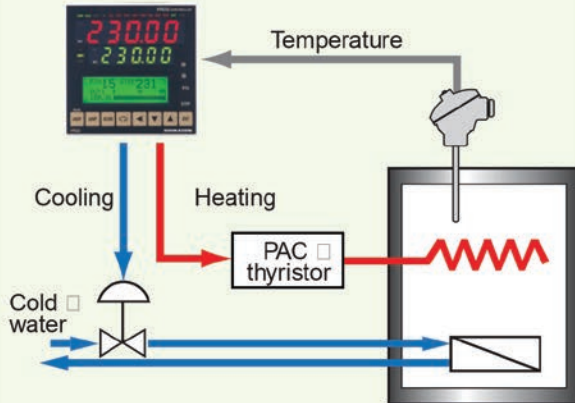

Constant-temperature/constant-humidity control

2-input Specification (Independent 2-loop control)

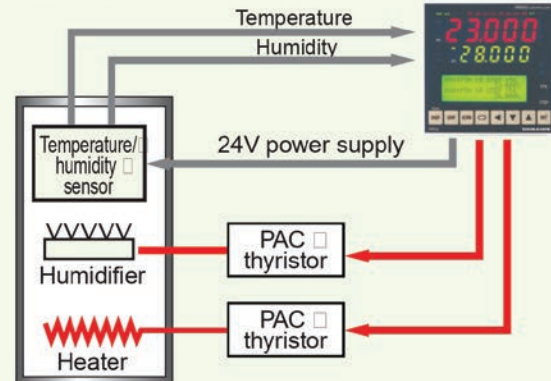

* Cooling (dehumidifying) may be achievable by using event output as well.

Differential Pressure Control

2-input Specification (2-input operation control)

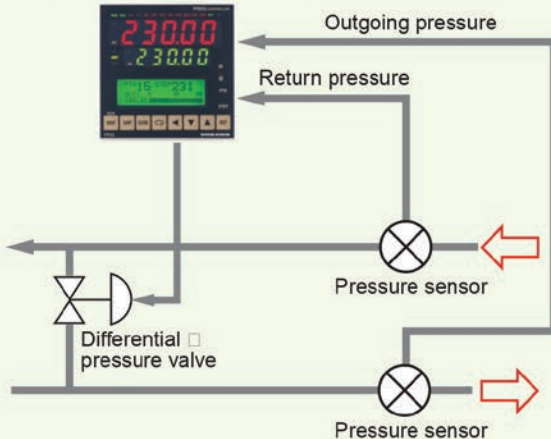

Widely Coping with Various Usages

- Semiconductor manufacturing equipment
- Electrical/electronic parts/components manufacturing-related equipment
- Various industrial furnaces
- Vacuum heating furnaces
- Environmental test equipment
- Food processing machines
- Plastic processing/molding machines
- Sterilization/pasteurization equipment for pharmaceuticals

- 1-output control

Ordering Information

ITEM	CODE		Specifications	
SERIES	FP23-		96 × 96 DIN size, high-performance programmable controller	
BASIC FUNCTIONS	SS		Universal-input, 1-input/1-output control, 3 event outputs	
CONTROL OUTPUT 1	Y		Contact 1c, contact rating: 240V AC 2.5A/resistive load, 1A/inductive load	
	I		Current 4 ~ 20mA DC, Load resistance: max. 600Ω	
	P		SSR drive voltage output 12V±1.5V DC, Load current: max. 30mA	
	V		Voltage 0 ~ 10V DC, Load current: max. 2mA	
CONTROL OUTPUT 2	N-		None	
HEATER BREAK ALARM (FOR SINGLE-PHASE)	00		None	
	31		Heater break alarm* (heater current 30A with CT)	* Selectable only when Control Output 1 is Y or P
	32		Heater break alarm* (heater current 50A with CT)	
ANALOG OUTPUT 1	0		None	
	3		0 ~ 10mV DC, Output resistance: 10Ω	
	4		4 ~ 20mA DC, Load resistance: max. 300Ω	
	6		0 ~ 10V DC, Load current: max. 2mA	
ANALOG OUTPUT 2/ SENSOR POWER SUPPLY	0		None	
	3		0 ~ 10mV DC, Output resistance: 10Ω	
	4		4 ~ 20mA DC, Load resistance: max. 300Ω	
	6		0 ~ 10V DC, Load current: max. 2mA	
	8		Sensor power supply 24V DC 25mA	
EXTERNAL INPUT/ OUTPUT CONTROL SIGNAL (DI/DO) *1	standard	0	DI 4 points, DO 5 points (start pattern No. switching not available)	
		1	DI 10 points, DO 9 points (start pattern No. switching available)	
		2	DI 10 points, DO 13 points (start pattern No. switching available)	
COMMUNICATION FUNCTION		0	None	
		5	RS-485	Shimaden standard protocol / MODBUS (RTU/ASCII) communication protocol
		7	RS-232C	
REMARKS		A	Without	
		9	With	

*1 When switching the start pattern No. by DI, 10 points of DI (CODE 1 or 2) are required.

Optional Accessories

Name	Model	Description
Infra-red Communication Adapter	S5004	USB connector cable (2m), Setup Software (CD-ROM)
Shunt Resistor	QCS002	250Ω ±0.1%, external input resistance at current input
Relay Unit	AP2MC	Converts open collector output to contact output. 2 circuits built-in

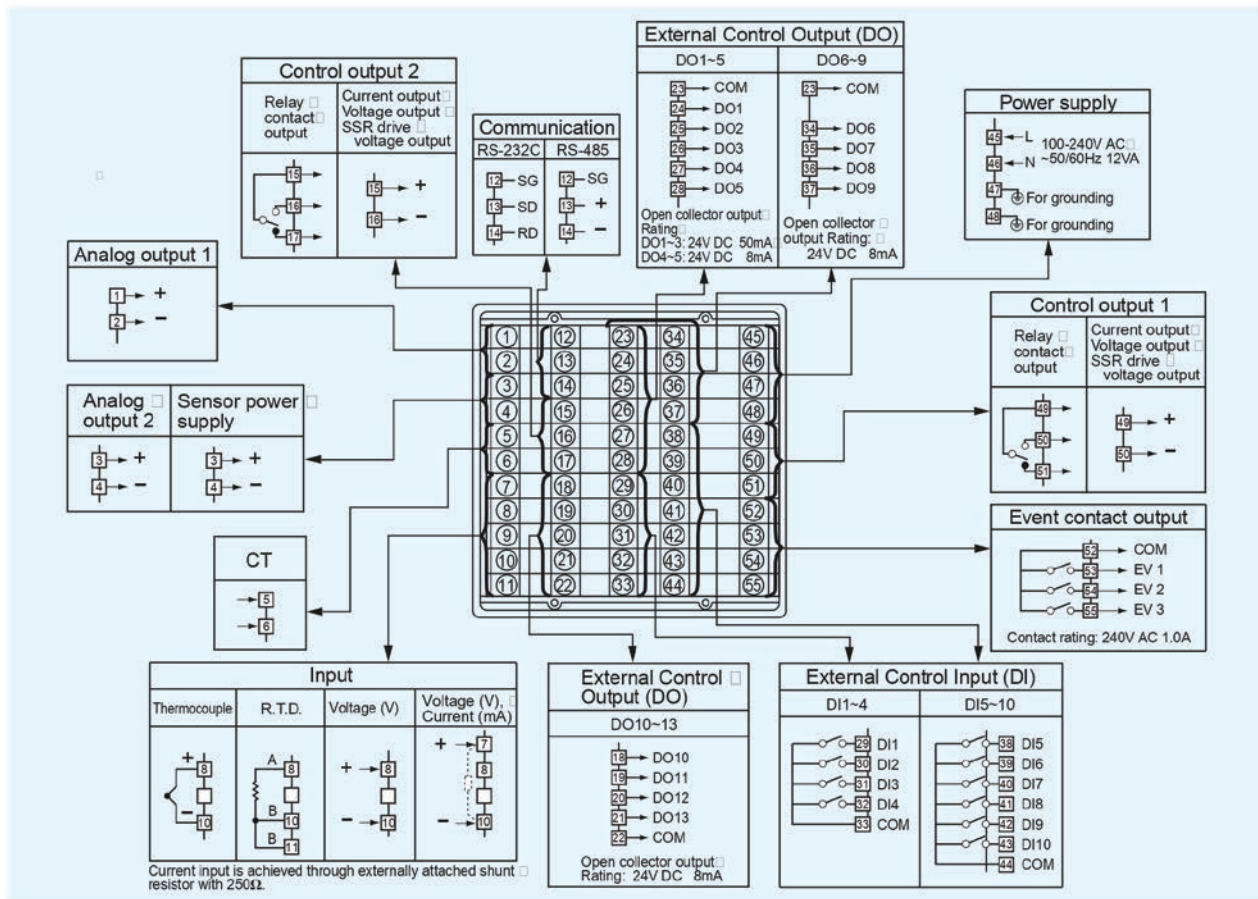

External Dimensions & Panel Cutout

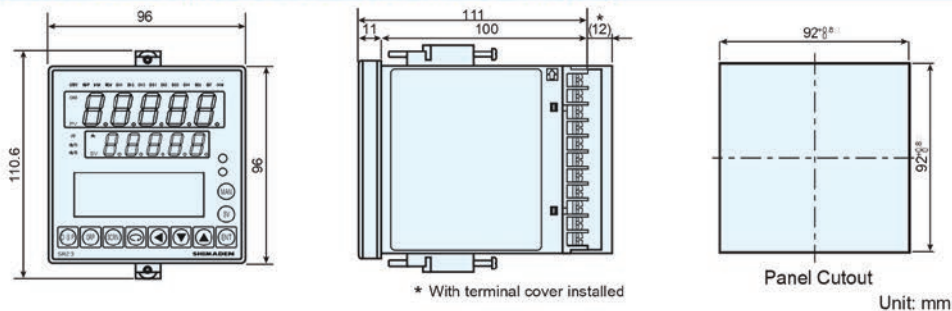

Accessories Required for Heater Break Alarm Function

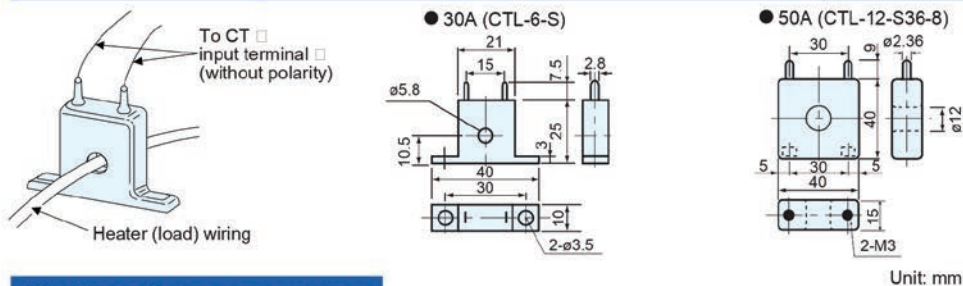

Optional Accessories

Relay Unit Model AP2MC
 (Converts open collector output to contact output. 2 circuits built-in)



Infra-red Communication Adapter Model S5004 with USB connector cable



- 2-output control (Heating/cooling control)

Ordering Information

ITEM	CODE		Specifications	
SERIES	FP23-		96 × 96 DIN size, high-performance programmable controller	
BASIC FUNCTIONS	SD		Universal-input, 1-input/2-output control, 3 event outputs	
CONTROL OUTPUT 1		Y	Contact 1c, contact rating: 240V AC 2.5A/resistive load, 1A/inductive load	
		I	Current 4 ~ 20mA DC, Load resistance: max. 600Ω	
		P	SSR drive voltage output 12V±1.5V DC, Load current: max. 30mA	
		V	Voltage 0 ~ 10V DC, Load current: max. 2mA	
CONTROL OUTPUT 2		Y-	Contact 1c, contact rating: 240V AC 2.5A/resistive load, 1A/inductive load	
		I-	Current 4 ~ 20mA DC, Load resistance: max. 600Ω	
		P-	SSR drive voltage output 12V±1.5V DC, Load current: max. 30mA	
		V-	Voltage 0 ~ 10V DC, Load current: max. 2mA	
HEATER BREAK ALARM (FOR SINGLE-PHASE) *1		00	None	
		31	Heater break alarm* (heater current 30A with CT)	* Selectable only when Control Output 1 or 2 is Y or P
		32	Heater break alarm* (heater current 50A with CT)	
ANALOG OUTPUT 1		0	None	
		3	0 ~ 10mV DC, Output resistance: 10Ω	
		4	4 ~ 20mA DC, Load resistance: max. 300Ω	
		6	0 ~ 10V DC, Load current: max. 2mA	
ANALOG OUTPUT 2/ SENSOR POWER SUPPLY		0	None	
		3	0 ~ 10mV DC, Output resistance: 10Ω	
		4	4 ~ 20mA DC, Load resistance: max. 300Ω	
		6	0 ~ 10V DC, Load current: max. 2mA	
		8	Sensor power supply 24V DC 25mA	
EXTERNAL INPUT /OUTPUT CONTROL SIGNAL (DI/DO) *2	standard	0	DI 4 points, DO 5 points (start pattern No. switching not available)	
		1	DI 10 points, DO 9 points (start pattern No. switching available)	
		2	DI 10 points, DO 13 points (start pattern No. switching available)	
COMMUNICATION FUNCTION		0	None	
		5	RS-485	Shimaden standard protocol / MODBUS (RTU/ASCII) communication protocol
		7	RS-232C	
REMARKS		A	Without	
		9	With	

*1 In a 2-output specification, the heater break alarm is used by either of Control Output 1 or 2.

*2 When switching the SV No. by DI, 10 points of DI (CODE 1 or 2) are required.

Optional Accessories

Name	Model	Description
Infra-red Communication Adapter	S5004	USB connector cable (2m), Setup Software (CD-ROM)
Shunt Resistor	QCS002	250Ω ±0.1%, external input resistance at current input
Relay Unit	AP2MC	Converts open collector output to contact output. 2 circuits built-in

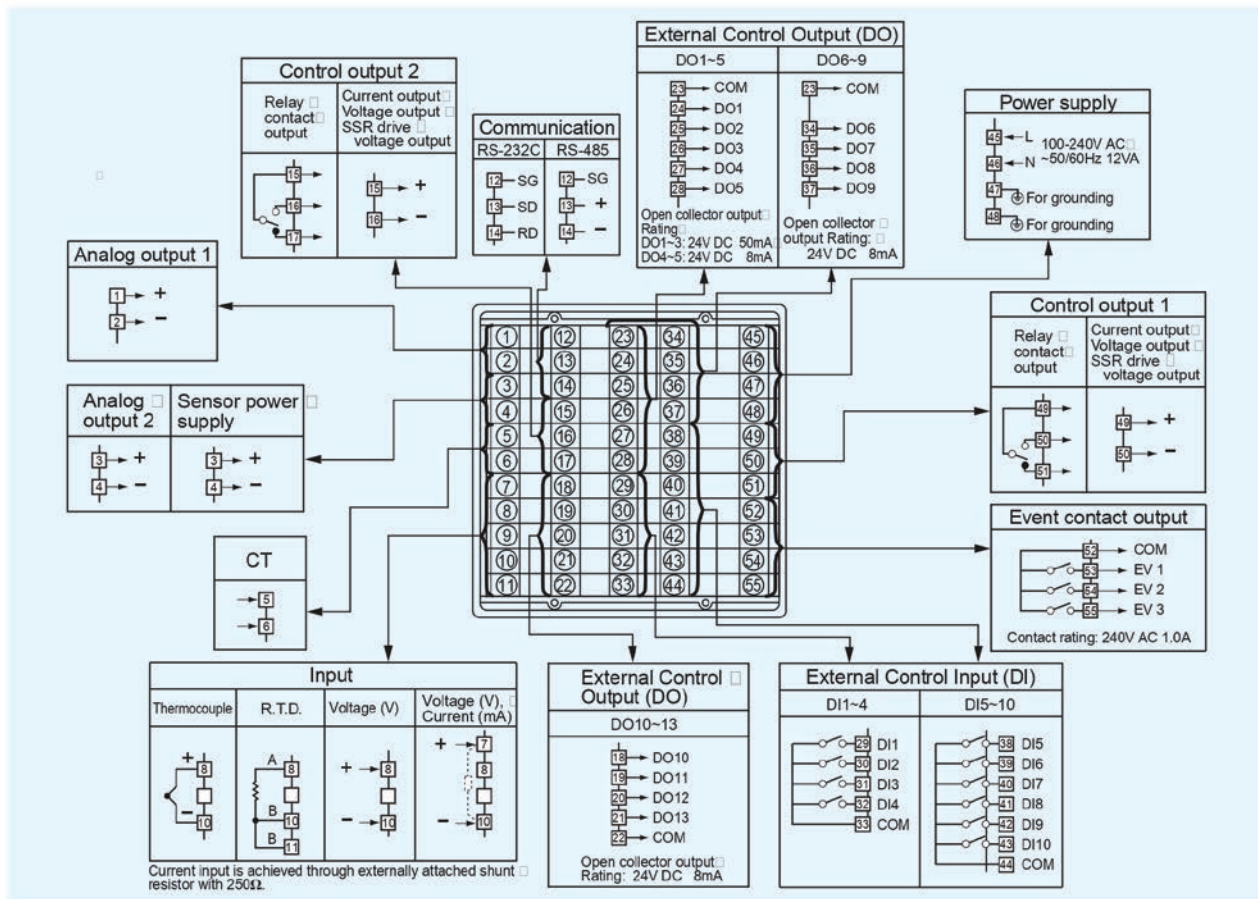

External Dimensions & Panel Cutout

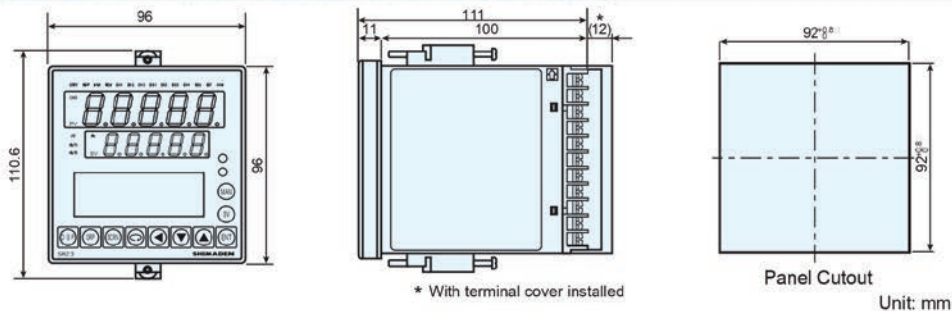

Accessories Required for Heater Break Alarm Function

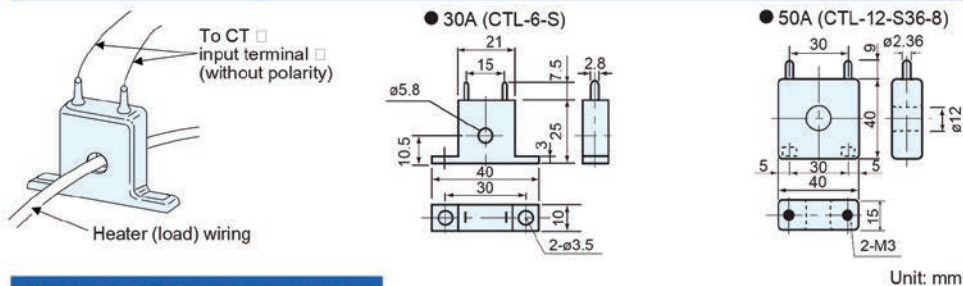

Optional Accessories

Relay Unit Model AP2MC
 (Converts open collector output to contact output. 2 circuits built-in)



Infra-red Communication Adapter Model S5004 with USB connector cable



- 2-input/2-output control (independent 2-loop control)
- 2-input operation/1-output control (1-loop control by max. value, min. value, average value, deviation value operation)
- 2-input operation/2-output control (1-loop heating/cooling control by max. value, min. value, average value, deviation value operation)

Ordering Information

ITEM	CODE		Specifications	
SERIES	FP23-		96 × 96 DIN size, high-performance digital controller	
BASIC FUNCTIONS *1	DL		Universal-input, independent 2-loop control, 3 event outputs	
	DS		Universal-input, 2-input operation/1-output control, 3 event outputs *2	
	DD		Universal-input, 2-input operation/2-output control, 3 event outputs	
CONTROL OUTPUT 1 *2	Y		Contact 1c, contact rating: 240V AC 2.5A/resistive load, 1A/inductive load	
	I		Current 4 ~ 20mA DC, Load resistance: max. 600Ω	
	P		SSR drive voltage output 12V±1.5V DC, Load current: max. 30mA	
	V		Voltage 0 ~ 10V DC, Load current: max. 2mA	
CONTROL OUTPUT 2	Y-		Contact 1c, contact rating: 240V AC 2.5A/resistive load, 1A/inductive load	
	I-		Current 4 ~ 20mA DC, Load resistance: max. 600Ω	
	P-		SSR drive voltage 12V±1.5V DC, Load current: max. 30mA	
	V-		Voltage 0 ~ 10V DC, Load current: max. 2mA	
HEATER BREAK ALARM (FOR SINGLE-PHASE) *3	00		None	
	31		Heater break alarm (heater current 30A with CT)	Selectable only when Control Output 1 or 2 is Y or P
	32		Heater break alarm (heater current 50A with CT)	
ANALOG OUTPUT 1	0		None	
	3		0 ~ 10mV DC, Output resistance: 10Ω	
	4		4 ~ 20mA DC, Load resistance: max. 300Ω	
	6		0 ~ 10V DC, Load current: max. 2mA	
ANALOG OUTPUT 2/ SENSOR POWER SUPPLY	0		None	
	3		0 ~ 10mV DC, Output resistance: 10Ω	
	4		4 ~ 20mA DC, Load resistance: max. 300Ω	
	6		0 ~ 10V DC, Load current: max. 2mA	
	8		Sensor power supply 24V DC 25mA	
EXTERNAL INPUT/OUTPUT CONTROL SIGNAL (DI/DO) *4	standard	0	DI 4 points, DO 5 points (start pattern No. switching not available)	
		1	DI 10 points, DO 9 points (start pattern No. switching available)	
COMMUNICATION FUNCTION		0	None	
		5	RS-485	Shimaden standard protocol/MODBUS (RTU/ASCII) communication protocol
		7	RS-232C	
REMARKS		A	Without	
		9	With	

*1 Independent 2-loop control, 2-input operation/1-output control and 2-input operation/2-output control are all supported in the 2-output specification. This controller is shipped with the function selected at BASIC FUNCTION set.

*2 In a 2-input operation/1-output control specification, output for control is output to Control Output 1. Select the same specification as Control Output 2 for Control Output 1.

*3 In a 2-output specification, the heater break alarm is used by either of Control Output 1 or 2.

*4 When switching the start pattern No. by DI, 10 points of DI (CODE 1) are required.

Optional Accessories

Name	Model	Description
Infra-red Communication Adapter	S5004	USB connector cable (2m), Setup Software (CD-ROM)
Shunt Resistor	QCS002	250Ω ±0.1%, external input resistance at current input
Relay Unit	AP2MC	Converts open collector output to contact output. 2 circuits built-in

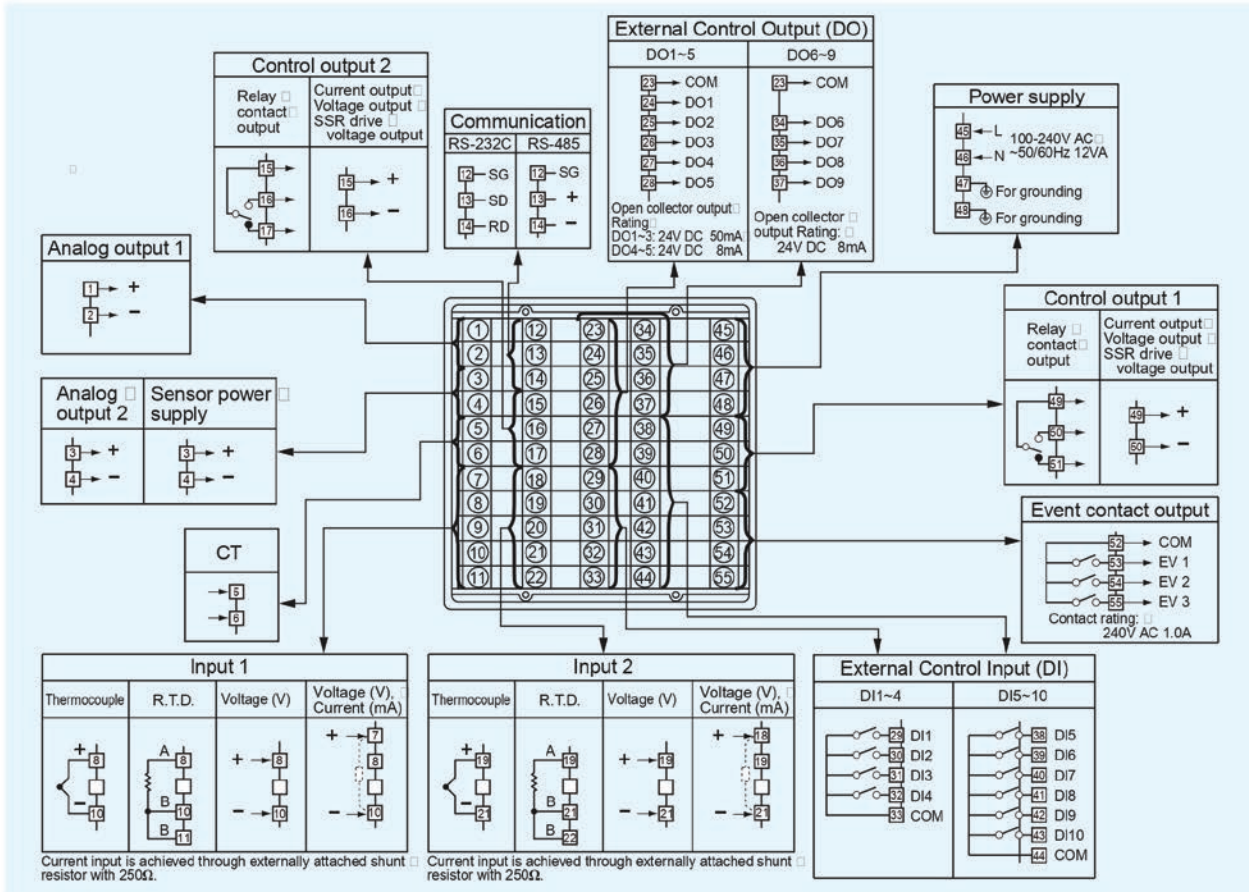

External Dimensions & Panel Cutout

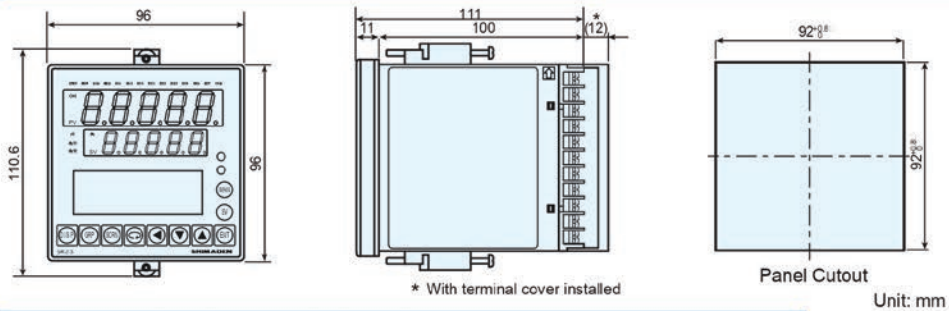

Accessories Required for Heater Break Alarm Function

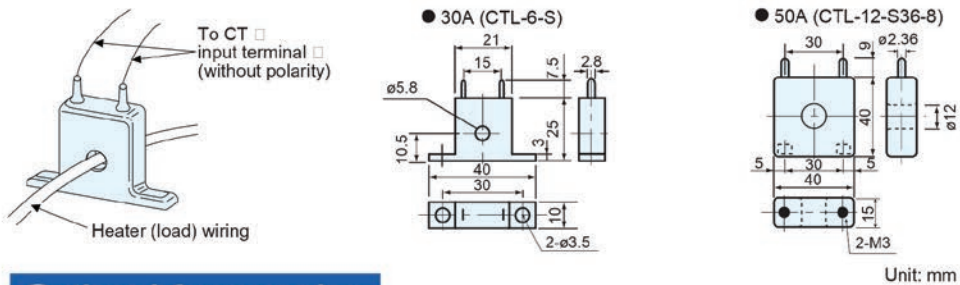

Optional Accessories

Relay Unit Model AP2MC
 (Converts open collector output to contact output. 2 circuits built-in)



Infra-red Communication Adapter Model S5004 with USB connector cable



Input type		Code	Measuring range		
Thermocouple	B	01	*1	0.0 ~ 1800.0°C	
	R	02		0.0 ~ 1700.0°C	
	S	03		0.0 ~ 1700.0°C	
	K	04			-100.0 ~ 400.0°C
		05			0.0 ~ 400.0°C
		06			0.0 ~ 800.0°C
		07			0.0 ~ 1370.0°C
		08	*2		-200.0 ~ 200.0°C
	E	09			0.0 ~ 700.0°C
	J	10			0.0 ~ 600.0°C
	T	11	*2		-200.0 ~ 200.0°C
	N	12			0.0 ~ 1300.0°C
	PL II	13			0.0 ~ 1300.0°C
	PR40-20	14	*3		0.0 ~ 1800.0°C
	WRe5-26	15			0.0 ~ 2300.0°C
	U	16			-200.0 ~ 200.0°C
	L	17			0.0 ~ 600.0°C
	K	18	*4		10.0 ~ 350.0 K
	Gold and Iron/Chromel	19	*5		0.0 ~ 350.0 K
R.T.D.	Pt	JPt			
	31	45	*6	-200.0 ~ 600.0 °C	
	32	46		-100.00 ~ 100.00 °C	
	33	47		-100.0 ~ 300.0 °C	
	34	48		-60.00 ~ 40.00 °C	
	35	49		-50.00 ~ 50.00 °C	
	36	50		-40.00 ~ 60.00 °C	
	37	51		-20.00 ~ 80.00 °C	
	38	52	*7	0.000 ~ 30.000 °C	
	39	53		0.00 ~ 50.00 °C	
	40	54		0.00 ~ 100.00 °C	
	41	55		0.00 ~ 200.00 °C	
	42	56	*8	0.0 ~ 300.0 °C	
	43	57		0.00 ~ 300.0 °C	
44	58		0.0 ~ 500.0 °C		

Input type		Code	Measuring range	
Voltage (mV)	-10 ~ 10mV	71		Initial value: 0.0~100.0 Measuring range may be arbitrarily set within following range by scaling function.
	0 ~ 10mV	72		
	0 ~ 20mV	73		
	0 ~ 50mV	74		
	10 ~ 50mV	75		
	0 ~ 100mV	76		
	-100 ~ 100mV	77		
Voltage (V)	-1 ~ 1V	81		Scaling range: -19999~30000 counts Span: 10~30000 counts Lower limit value < Higher limit value Decimal alignment: None, decimal positions: 1, 2, 3 or 4
	0 ~ 1V	82		
	0 ~ 2V	83		
	0 ~ 5V	84		
	1 ~ 5V	85		
	0 ~ 10V	86		
	-10 ~ 10V	87		
Current (mA)	0 ~ 20mA	84		*If you use this with current input, please attach external shunt resistor with 250Ω.
	4 ~ 20mA	85		

Note: Minimal decimal is selectable.

Note:

- *1. Thermocouple B: Accuracy not guaranteed for temperatures below 400°C
- *2. Thermocouple K, T: Accuracy = ± (0.5% FS+1 digit) for -100°C or lower temperature
- *3. Thermocouple PR40-20: Accuracy = ± (0.3% FS + 1°C)
- *4. Thermocouple K: 10.0~30.0 K: Accuracy = ± (0.75% FS + 1 K)
30.0~70.0 K: Accuracy = ± (0.30% FS + 1 K)
70.0~350.0 K: Accuracy = ± (0.25% FS + 1 K)
- *5. Thermocouple Gold and Iron/Chromel: Accuracy = ± (0.25% FS + 1 K)
- *6. For JPt100, set to -200.0~500.0°C.
- *7. When exceeding higher limit at 30.000°C, indicated as scaleover.
- *8. When exceeding higher limit at 300.00°C, indicated as scaleover.

Note: Unless otherwise specified, the measuring range will be set as listed below during the shipment from the factory.

Input	Standard/Rating	Measuring range
Thermocouple	JIS K	0.0~800.0°C

Warning

- The SR23 series is designed for the control of temperature, humidity and other physical values of general industrial equipment. (It is not to be used for any control purpose when a serious potential effect may result on human life or safety.)

Caution

- If the possibility of loss or damage to your system or property as a result of failure of any part of the process exists, proper safety measures must be made before the instrument is put into use so as to prevent the occurrence of trouble.

(The contents of this brochure are subject to change without notice.)

Temperature and Humidity Control Specialists
SHIMADEN CO., LTD.
 Head Office: 2-30-10 Kitamachi, Nerima-Ku, Tokyo 179-0081 Japan
 Phone: +81-3-3931-7891 Fax: +81-3-3931-3089
 E-MAIL: exp-dept@shimaden.co.jp URL: http://www.shimaden.co.jp



05SR23ILC