

**RM18G/RM18N****HYBRID RECORDER****OUTLINE**

THE RM18G AND RM18N ARE HYBRID RECORDER ALLOWS DIGITAL PRINTOUT ON ANALOG TREND OR PEN TRACES ON 180 mm WIDE CHART PAPER. THE RM18G OFFERS 288 x 288 mm DIN SIZE PANEL AND THE RM18N(M) REPLACES MONITOR MODEL RECORDER.

**FEATURES**

- CONTACT FREE FEEDBACK POTENTIOMETER AND INPUT SELECTOR
- EASY CHANNEL IDENTIFICATION BY MARK PRINTER
- BOTH TREND & DATA LOGGING PRINTOUTS
- DIELECTRICS STRENGTH OF 2000V BETWEEN POWER INPUT AND GROUND
- ABUNDANCE OF PRINTOUT FUNCTION
- INDIVIDUAL SCALE PLATE
- WIDE RANGE OF POWER SUPPLY VOLTAGE
- OPTIONAL IC CARD

**SPECIFICATIONS**

Number of inputs: 1,2,3,4 pen, 6,12,24, or 30 dot point.

**Type of input:**

**DC Voltage:** 4mVDC min., 20VDC max.

**Direct thermocouple:** K, T, J, E, B, S, R, G, C, N, PR40-20, PLII, U, L, Au-Fe

**RTD:** Pt100Ω, Pt50Ω, JPt100Ω, Cu10Ω (at 0°C), Cu10Ω (at 25Ω)

**Current:** 4 ~ 20mA

**Conductivity:** 100μS/m ~ 2000mS/m

**Recording width:** 180mm calibrated

**Recording accuracy:** ± 0.5% max.

**Open input protection (option):** Up scale with mV or TC input

**Chart Speed:** 1, 2, 3 & 4 pen model; 1 ~ 3600mm/h  
6, 12, 24 & 30 point model; 1 ~ 1800mm/h

**Chart paper:** Fold chart standard, 23m long, 210mm width

**Data print color:** Purple (Red on alarm)

**Dot print interval:** 2.5/ 5/ 10 s/ch.

**Input sampling:** 120 msec. in pen model, 2.5/ 5/ 10 s/ch in dot point model.

**Cartridge pen:** Disposable felt pen

**Print head:** Pen models; Wire dot 1 color ribbon cartridge,  
Dot point models; 6 color ribbon cartridge

**Alarm:** 6 Set points per channel

**Alarm output (option):** 2 relays drive per setting. Form-C  
250VAC 3A /125VDC 0.5A/30VDC 3A max.,  
Hysteresis 0.5 ± 0.2%, Setting accuracy ± 0.5%

**Input impedance:** 10MΩ min. In mV/TC input. 200kΩ min.  
In mV/TC Input with burn-out, 1MΩ min.

In Volt Input and 100Ω min. In mA Input

**Source impedance:** 10kΩ max. in mV/TC input, 200Ω  
max. in mV/TC Input with burn-out, 1kΩ  
max. In Volt input and 10Ω max. per wire in RTD input.

**CMRR:** 140dB min. in 50/60 ± 0.5Hz

**NMRR:** 60dB min. in 50/60 ± 0.5Hz

**Isolation resistance:** Input/ground 500VDC, 20MΩ min.

**Dielectric strength:** Power supply voltage/ ground 2000VAC,  
1 minute duration. input/ground 500VAC, 1 minute  
duration

**Power supply voltage:** 85 ~ 264VAC, 45 ~ 65Hz ± 5%

**Allowable instant power failure:** 50ms max.

**Power consumption:** 70VA max.

**Vibration resistance:** 1m/s<sup>2</sup> max., 10 ~ 60Hz

**Shock resistance:** 2m/s<sup>2</sup> max.

**Operating conditions:** -5 ~ 50°C. 35 ~ 85%RH

**Dimensions:** RM18G; 288 x 288 x 340 mm.

RM18N; 288(w) x 322(h) x 340(d) mm

**Case structure:** Dust-proof

**Mounting:** Panel-mount

Allowable backward inclination : 30°

**Material:** Case — Steel plate

Door frame — Aluminum die casting

**Color:** Case — Metallic silver

Door frame — Black(Standard)

**Alarm types:** 6 types/ channel (H,HH,L,LL,RH,RL)

**Drives:** 2 relay drive/alarm set value

**Alarm output:** 250 V AC, 3 A max. (resistance load)  
125 V DC, 0.5 A max. (resistance load)  
30 V DC, 3 A max. (resistance load)

**Hysteresis width:** 0.5 ± 0.2 %

**Setting accuracy:** ± 0.5 %

### MAXIMUM RANGE & ACCURACY

The Junction compensation accuracy is not added to digital readout accuracy and recording accuracy. The junction compensation accuracy is based on operating conditions: 23 ± 2°C temperature; 55 ± 10%RH humidity; 85 ~ 264VAC power source; 30 minutes min. warm-up time; no effect of vibration resistance and shock resistance.

Limit of compensation error: ± 1°C at R,S,B,PR40-20  
± 0.5°C at K,E,J,T,G,C,N

#### Resolution:

Range Code	Max. Resolution
000 & 001	10uV
002	100uV
003,004,006,007	1mV
005	10mV
008	0.01mA
010-047, 049-058	0.1°C
048	0.1K

Digital readout accuracy: ± (0.2% + 1digit)

Recording accuracy: ± 0.5%

#### NOTE:

(\*1): Extension scaling up to 3 times among each ranges: ± (0.3% + 1digit)

(\*2): Ranges under a span of 0 ~ 400°C, can not guarantee accuracy

(\*3): Ranges of 0 ~ 300°C: ± 2%, 300 ~ 800°C: ± 1%

(\*4): Ranges of 0 ~ 200°C: ± 0.3% + 1digit

(\*5): ± (0.5% + 1digit)

(\*6): ± (0.8% + 1digit)

(\*2 ~ \*6):

Recording accuracy = digital readout accuracy ± 0.3%

### RANGE TABLE

GROUP	INPUT	CODE	RANGE(*1)	
Volt	mV	000	- 10.0 ~ +10.0mV	
	mV	001	- 50.0 ~ +50.0mV	
	mV	002	- 200.0 ~ +200.0mV	
	V	003	- 1.0 ~ +1.0V	
	V	004	- 5.0 ~ +5.0V	
	V	005	- 20.0 ~ +20.0V	
	V	006	0.0 ~ +5.0V	
	V	007	+1.0 ~ +5.0V	
Current	mA	008	4.0 ~ 20.0mA	
TC	R	010	0.0 ~ 1450.0°C	
	R	011	0.0 ~ 1760.0°C	
	S	012	0.0 ~ 1760.0°C	
	B	013	0.0 ~ 1830.0°C (*2)	
	K	014	0.0 ~ 100.0°C	
	K	015	0.0 ~ 700.0°C	
	K	016	0.0 ~ 900.0°C	
	K	017	- 200.0 ~ 100.0°C	
	K	018	- 200.0 ~ 400.0°C	
	K	019	- 200.0 ~ 650.0°C	
	K	020	- 200.0 ~ 1370.0°C	
	K	021	0.0 ~ 1000.0°C	
	E	022	0.0 ~ 150.0°C	
	E	023	0.0 ~ 400.0°C	
	E	024	- 200.0 ~ 500.0°C	
	E	025	- 200.0 ~ 600.0°C	
	E	026	- 200.0 ~ 900.0°C	
	E	027	- 200.0 ~ 250.0°C	
	E	028	- 200.0 ~ 400.0°C	
	E	029	- 200.0 ~ 700.0°C	
	J	030	0.0 ~ 150.0°C	
	J	031	0.0 ~ 500.0°C	
	J	032	- 200.0 ~ 650.0°C	
	J	033	- 200.0 ~ 300.0°C	
	J	034	- 200.0 ~ 500.0°C	
	J	035	- 200.0 ~ 900.0°C	
	J	036	- 200.0 ~ 750.0°C	
	T	037	0.0 ~ 150.0°C	
	T	038	0.0 ~ 400.0°C	
	T	039	- 200.0 ~ 350.0°C	
	T	040	- 200.0 ~ 400.0°C	
	G	041	0.0 ~ 2320.0°C	
	C	042	0.0 ~ 2320.0°C	
	N	043	0.0 ~ 900.0°C	
	N	044	0.0 ~ 1260.0°C	
	PR40-20	045	0.0 ~ 1880.0°C (*3)	
	U	046	- 200.0 ~ 400.0°C (*4)	
	L	047	- 200.0 ~ 900.0°C (*4)	
	Au-Fe	048	0.0 ~ 300.0°C (*5)	
	RTD	JPt100	049	- 50.0 ~ 100.0°C
		JPt100	050	- 200.0 ~ 600.0°C
		Pt100	051	- 50.0 ~ 100.0°C
		Pt100	052	- 200.0 ~ 600.0°C
		JPt50	053	- 50.0 ~ 100.0°C
		JPt50	054	- 100.0 ~ 250.0°C
		JPt50	055	- 200.0 ~ 550.0°C
		Cu10Ω at 25°C	056	- 50.0 ~ 200.0°C (*6)
		Cu10Ω at 0°C	057	- 50.0 ~ 200.0°C (*6)
TC		PLII	058	0.0 ~ 1360.0°C

## CONDUCTIVITY RECORDER

**Sensor:** Thermistor (2.5kΩ at 25°C, 400Ω at 25°C), Pt1000Ω at 0°C

**Solution temperature compensation:** Auto temp. compensator provided temp. Sensor by Thermistor for 5 ~ 45°C, Pt1000Ω for 0 ~ 100°C

Note 1: To be specified from 2.5

Note 2: Unavailable for purity water

**Recording accuracy:** ± 0.5% at 25°C

**Temperature characteristics:** ± 0.3% /10°C

**Isolation resistance:** Input/ground 200VDC, 20MΩ min., Other terminal than Input/ground 500VDC, 20MΩ min.

**Dielectric strength:** Input/ground 200VAC, 1 minute duration, power Input/ground 2000VAC. 1 minute duration

**Common mode reduction ratio:** 100dB min (50/60 ± 0.5Hz)

### RANGE AND MAX. CABLE LENGTH

Length described below is based under use of our exclusive 3-cored or 5-cored cable.

Model: 3-cored cable: IPS0245A1500

5-cored cable; WPSN040A000001A

RANGE CODE	CELL CONSTANT	RANGE	MAX. CABLE LENGTH(m)
00	1 (m <sup>-1</sup> )	0 ~ 100.0μS/m	50
01		0 ~ 200.0μS/m	90
02		0 ~ 500.0μS/m	90
03		0 ~ 1000μS/m	90
04	10 (m <sup>-1</sup> )	0 ~ 1.000mS/m	50
05		0 ~ 2.000mS/m	90
06		0 ~ 5.000mS/m	90
07		0 ~ 10.00mS/m	90
08	100 (m <sup>-1</sup> )	0 ~ 10.00mS/m	50
09		0 ~ 20.00mS/m	90
10		0 ~ 50.00mS/m	90
11		0 ~ 100.0mS/m	90
12		0 ~ 200.0mS/m	25
13	1000 (m <sup>-1</sup> )	0 ~ 100.0mS/m	50
14		0 ~ 200.0mS/m	90
15		0 ~ 500.0mS/m	90
16		0 ~ 1000.0mS/m	90
17		0 ~ 2000.0mS/m	25

## STANDARD FUNCTIONS

FUNCTION	DESCRIPTION
Analog indication	Process variable is indicated on a scale plate.
Recording	Pen tracing (pen models), Printing with 5 marking by 6 color ribbon cartridge (dot point models).
Engineering unit indication	Engineering unit is indicated on the scale plate.
Digital display	Indicates channel no., process variable, date, chart speed, alarm set point in the display 1 & 2.
Scaling	Indicates and prints process variable with set point.
Logging print	Prints each channel's process variable, engineering unit on the chart paper. Printing mode is selected from analog recording, end mode for analog recording.
Date print	Prints year and date at a programmed time.
Time print	Prints time at a Programmed interval.
List print	Prints type of input, range, engineering unit, alarm set point, date, time, chart speed, scaling and logging print status on the chart paper.
Skip	Abandon dot print of inputs as required by dot point models.
Programming	Chart speed, alarm set point, logging print interval, skip, date and time can be programmed.
Memory backup	Back-up for clock by lithium batteries for 10 years or 5 years in unused and for program by non-volatile memory.
Key lock	If you don't use key for more than 5 minutes in a user mode, the key would be locked automatically.
Alarm	6 set points alarm per channel.
Chart speed	2 chart speeds can be programmed.
Time indicator	Indicates year, month, day, hour, minute. Adjust for leap year automatically
Self diagnostics	Indicates "ERROR", and outputs when CPU, printer, ADC are faulty.
Fail alarm	Outputs when faulty.
Common alarm	Outputs in alarming.



## OPTION 2

CODE	FUNCTION	DESCRIPTION
A01	Burn-out	Sets Indicator at over 100% or 0% per Inputs when input becomes open for TC or $\pm 50\text{mV}$ max. Input.
A02	Zone recording	Recording on the Chart track ranged per Inputs.
A03	Partial compression and enlargement	Partial compression and enlargement in the same range can be done.
A04	Pen gap rectifying	Keep process time on pen tracks.
A05	Scale print	The scale values of zero point and span point of each channel are printed.
A06	Alarm print	When an alarm arises, alarm-on time, alarm-on channel, alarm setting number, and alarm mode are printed in purple color.
A07	Alarm recovery print	When an alarm is recovered, the time of recovery, the recovered channel, alarm setting number, and alarm mode are printed in purple color.
A08	Digital filter	Execute the first-order lag recording of the measured value through the digital filter.
A09	Changing range	Change ranges with DI, 2 ranges max.
A10	Integration sum	Indicates and prints sum among channels.
A11	Integration balance	Indicates and prints balance among channels.
A12	Average among channels	Indicates and prints average among channels.
E01	Temperature balance	The actual temperature after subtracting the reference temperature of reference channel is designated and recorded.
E02	New alarm	New alarm channel is output in one-shot relay.
E04	Digital display ON/OFF	To turn off the designated value in the display through Auto Mode.
E05	Adjustment of print gap	To adjust a gap on the time axis between 1-pen and print.
E06	Max., min. and average value on print	Prints max., min. and average per inputs in logging print.
E07	Hysteresis width	Hysteresis width can be set. (Standard : 0.5% FS)
E09	Fail alarm converse output	Outputs in operating, stops in power failure.
D02	DE connection	To execute the compensating temperature, taking in, the inside temperature of outside compensating box by thermocouple input of the set channel.
D03	DH connection	To execute the compensating temperature, taking in, the inside temperature of outside compensating box by the voltage wire (copper wire) of the set channel.

**NOTE:** Recording accuracy may change in case optional Zone Recording or Expanded/Reduced Recording is installed.

## DI REMOTE OPTIONS

CODE	FUNCTION	DESCRIPTION
B01	Chart start/stop	Close: starts Open: stops
B02	Change chart speed	Close: 1st Open: 2nd
B03	Aux. chart drive	Chart feeding for external chart drive source
B04	Change chart drive source	Close: Internal Open: External
B05	Comment print 1	Prints up to 16 characters per verse.
B06	Comment print 2	
B07	Comment print 3	
B08	Comment print 4	
B09	Comment print 5	
B10	Remote logging print	Close: starts to print
B11	Remote date print	Close: starts to print
B12	Range change 1	Close: changes range
B13	Range change 2	
B14	Range change 3	
B15	Range change 4	
B16	Integration input	Integrates in proportion to contact closing times
B17	Integration reset	Resets Integrated value
B18	New alarm reset	Close: executes to reset New Alarm

## OTHER OPTIONS

CODE	DESCRIPTION
A13	Dot print interval 2.5 sec.
A14	Dot print interval 10 sec.
C01	Frosted glass
C04	Clean chart
D04	Conductivity input
E03	Lamp hold/reset
E08	Manual chart speed change

**ALARM BOARD:** 8 or 30 relays.

## COMMUNICATION INTERFACE

FUNCTION	DESCRIPTION
INTERFACE	RS-232C
	RS-422A
	ARCNET

## IC MEMORY CARD

CODE	DESCRIPTION
F03	256K byte
F04	512K byte
F05	1M byte
F06	2M byte

- 1: Load and save available for programmed data.
- 2: Memory available for measured data.
- 3: Printing available for day and month report.
- 4: Back-up available for integration in instant Power failure.

## OUTSIDE DIMENSION

(Unit : mm)

### RM18G TYPE

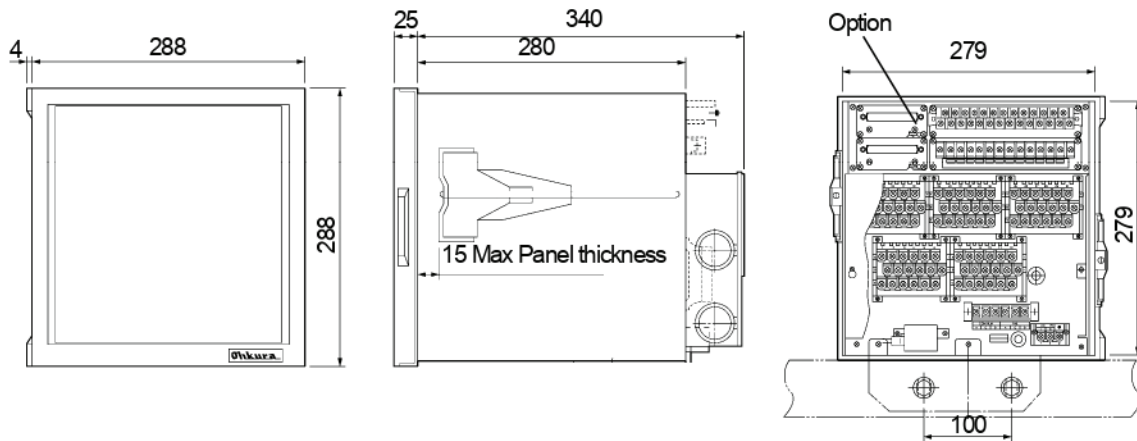

### RM18N TYPE

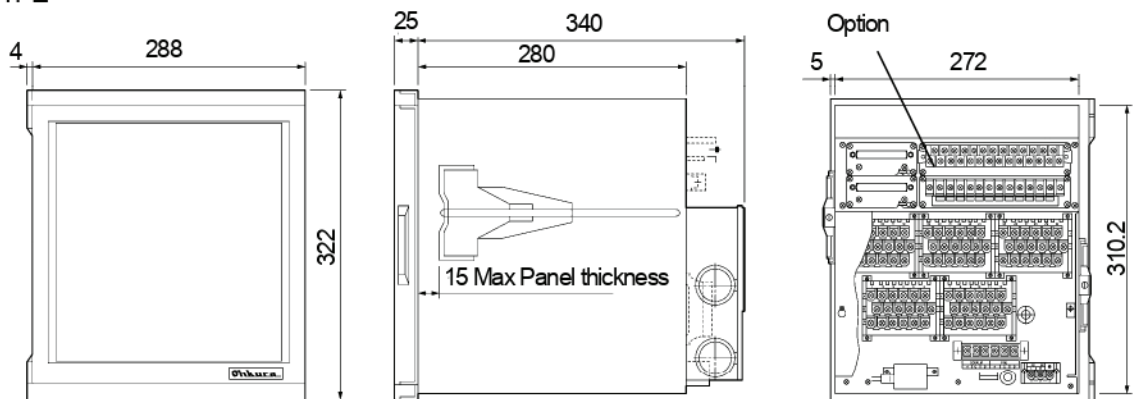

## PANEL CUTOUT

(Unit : mm)

### RM18G TYPE

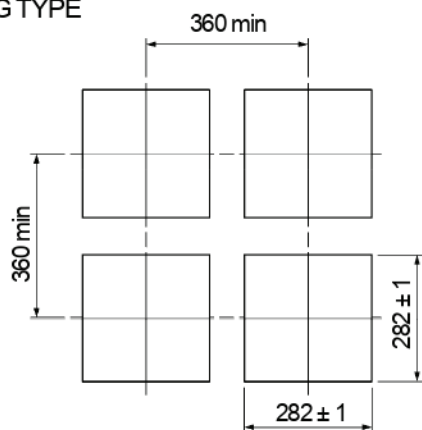

### RM18N TYPE

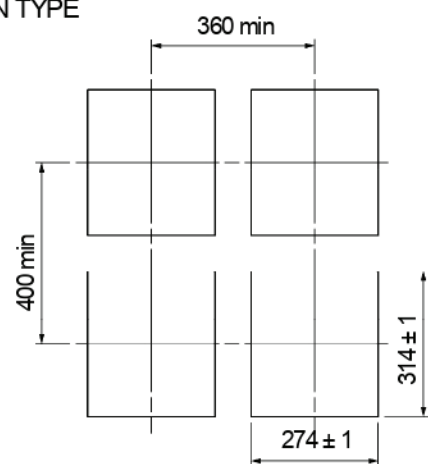

Door open angle: 135°

Panel: Steel plate, 3mm thickness min.

# TERMINAL ARRANGEMENT

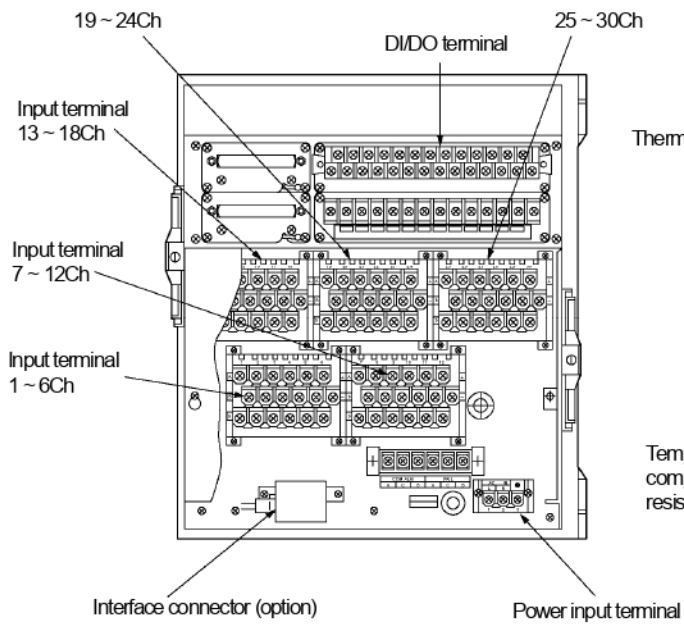

## Wiring

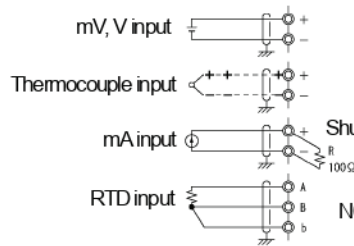

## Input terminal

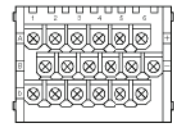

NOTE: Shunt resistance is installed on the terminal

## Conductivity recorder 3-cored input

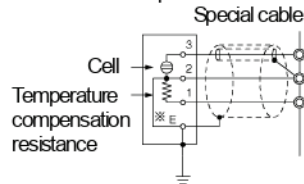

## Conductivity recorder 5-cored input

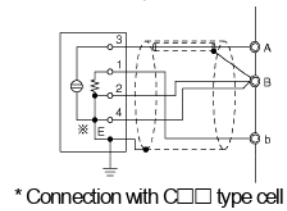

## Power wiring

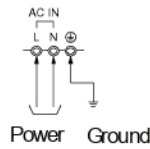

## Power terminal details

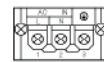

## Alarm output terminal

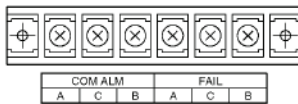

## MODEL CODE NUMBER

MODEL	BASE INSTRUMENT	
RM1801	1 pen recorder	
RM1802	2 pen recorder	
RM1803	3 pen recorder	
RM1804	4 pen recorder	
RM1806	6 point recorder	
RM1812	12 point recorder	
RM1824	24 point recorder	
RM1830	30 point recorder	
CODE	STRUCTURE	
G	Standard	
N	Equivalent panel cut size of the old model 15R	
CODE	COMMUNICATION INTERFACE	
0	None	
1	RS-232C	
2	RS-422A	
9	Special	
CODE	D/DO	
00	None	
01	DO(52)	
02	DI(24)	
03	DI(5)	
04	DI(5) + ARCNET	
05	8 relays	
06	DO(52) + DI(24)	
07	DO(52) + DI(5)	
08	DO(52) + DI(5) + ARCNET	
09	DO(52) + 8 relays	
10	DI(24) + DI(5)	
11	DI(24) + DI(5) + ARCNET	
12	DI(24) + 8 relays	
13	DI(5) + 8 relays	
14	DI(5) + ARCNET + 8 relays	
15	DO(52) + DI(24) + DI(5)	
16	DO(52) + DI(24) + DI(5) + ARCNET	
17	DO(52) + DI(24) + 8 relays	
18	DO(52) + DI(5) + 8 relays	
19	DO(52) + DI(5) + ARCNET + 8 relays	
20	DI(24) + DI(5) + 8 relays	
21	DI(24) + DI(5) + ARCNET + 8 relays	
22	DO(52) + DI(24) + DI(5) + 8 relays	
23	DO(52) + DI(24) + DI(5) + ARCNET + 8 relays	
24	30 relays	
CODE	ILLUMINATION, PANEL CALIBRATION, IC MEMORY CARD	
0	None	
1	Illumination (Note 1)	
2	Panel calibration (Note 2)	
3	IC Memory Card (Note 3)	
4	Illumination + Panel calibration (Note 2)	
5	Illumination + IC Memory Card (Note 3)	
6	Panel calibration + IC Memory Card (Note 3)	
7	Illumination + Panel calibration + IC Memory Card (Note 3)	
CODE	FRONT BEZEL COLOR	
1	N1.5 (Standard)	
2	7.5BG4/1.5	
3	N4	
4	N7	
5	7.5BG6/1.5	
9	Special	
CODE	QUAKE RESISTING SPEC	
A	None	
B	Yes	
CODE	OPTION	
0	None	
1	Provided (Fill "1", if any option for code from A01 to F06 is Installed)	
CODE	CUSTOM HARDWARE/SOFTWARE	
0	None	
C	Conductivity recorder	
X	Custom hardware (Consult factory)	
Y	Custom software (Consult factory)	
Z	Custom hardware + software (Consult factory)	

Note 1: Unavailable on 4 pen recorder.

Note 2: Available on multipoint recorder which input type other than T/C, Conductivity.

Note 3: To be added price of IC memory card for applicable capacity from code F03 to F06.

Note 4: Conductivity recorder can be specified on 6 or 12 point recorder, input mixture unavailable.

## MONITOR TYPE MODEL CODE NUMBER

MODEL	BASE INSTRUMENT	
RM1824	24 point recorder	
RM1830	30 point recorder	
	CODE	STRUCTURE
	G	Standard
	N	Equivalent panel cut size of the old model SM24
	CODE	COMMUNICATION INTERFACE
	0	None
	1	RS-232C
	2	RS-422A
	9	Special
	CODE	DO
	00	None
	05	8 relays
	24	30 relays
	CODE	ILLUMINATION
	0	None
	1	Illumination
	CODE	FRONT BEZEL COLOR
	1	N1.5 (Standard)
	2	7.5BG4/1.5
	3	N4
	4	N7
	5	7.5BG6/1.5
	9	Special
	CODE	QUAKE RESISTING SPEC
	A	None
	B	Yes
	CODE	MONITOR TYPE
	0M	



## STANDARD ACCESSORIES

DESCRIPTION	MODEL	MODEL / NUMBERS					NOTE
		1PEN	2PEN	3PEN	4PEN	DOT POINT	
Box	H2H07827	1	1	1	1	1	
Lubricant	H4A12290	1	1	1	1	1	
Fuse	WPSJ011D00001A	1	1	1	1	1	
Chart paper	HZCAA1025AF001	1	1	1	1	1	100 division
Cartridge pen No.1	HPSR001L0001	1	1	1	1		Red
Cartridge pen No.2	HPSR001L0002		1	1	1		Blue
Cartridge pen No.3	HPSR001L0003			1	1		Green
Cartridge pen No.4	HPSR001L0004				1		Purple
Ribbon cassette	HPSR001H0003	1	1	1	1		Purple
Ribbon cassette	HPSR001H0005					1	6 color
Wrench	HPSAA003A001					1	for M3 screw
Mounting bracket	H4A13299	2	2	2	2	2	RM18G
	H4A13611						RM18N
Instruction manual	HXPRM18mnG0001E	1	1	1	1		
	HXPRM18mnG0002E					1	
Engineering data manual	HXPRM18mnG0003E	1	1	1	1		
	HXPRM18mnG0004E					1	

## CAUTION

Do not install this device before consulting instruction manual

**Ohkura**

OHKURA ELECTRIC CO., LTD.

Head Office / Factory

Sales Offices

URL

e-mail (in English)

Saitama, JAPAN

Tokyo, Osaka, Nagoya, Kyushu

<http://www.ohkura.co.jp/>

[contact\\_e@ohkura.co.jp](mailto:contact_e@ohkura.co.jp)

Specifications are subject to change without notice.

For further information, a quotation or a demonstration please contact to:

Printed in Japan: June 2016