

# 3HXOL Series

## PRODUCT DATA SHEET

### Fluoropolymer Heater

**Excellent chemical resistance to aggressive acids!**

Inert to most solutions

Low Watt density design saves space & ensures long life

Corrosion-resistant head

Grounded internal metal element & non-floating construction



Up to 100°C (212°F)



3,000 to 18,000 Watts



120 to 600 Volts  
(600V on 12,000W or lower only)



PTFE sleeved 304 stainless steel



cULus  
CE (except 600 Volts)

3HXOL SERIES, MULTI ELEMENT L-SHAPED FLUOROPOLYMER (PTFE) HEATERS							
WATTS	VOLTS	WIDTH in/(mm)	HEATER PAD LENGTH in/(mm)	STD. VERT. LENGTH in/(mm)	MAX. COLD ZONE in/(mm)	MODEL NUMBER	SHIP WGT. lbs/(kg)
3000	240	8	13	18	36	3HXOL3208-13-R*-**	20
		(203)	(330)	(460)	(915)	3HXOL3408-13-R*-**	(9.1)
4500	240	10.5	11	18	35	3HXOL4.5210.5-11-R*-**	21
			(263)	(280)	(460)	(890)	3HXOL4.5410.5-11-R*-**
6000	240	10.5	19	18	35	3HXOL6210.5-19-R*-**	22
			(263)	(485)	(460)	(890)	3HXOL6410.5-19-R*-**
9000	240	10.5	23	18	35	3HXOL9210.5-23-R*-**	36
			(263)	(585)	(460)	(890)	3HXOL9410.5-23-R*-**
12000	240	10.5	30	18	35	3HXOL12210.5-30-R*-**	42
			(263)	(760)	(460)	(890)	3HXOL12410.5-30-R*-**
15000	240	10.5	36	18	31	3HXOL15210.5-36-R*-**	48
			(263)	(915)	(460)	(790)	3HXOL15410.5-36-R*-**
18000	240	10.5	42	18	25	3HXOL18210.5-42-R*-**	54
			(263)	(1070)	(460)	(635)	3HXOL18410.5-42-R*-**

Three-phase standard. Guards recommended.

## Features & Values

- Inert to most aqueous acid, alkaline, anodizing, & pickling solutions up to 100°C (212°F)
- Rugged, heavy wall PTFE covered stainless steel element reduces permeation. Guaranteed 100% pinhole free
- Space saving & long service life with low Watt density design of 10 W/in<sup>2</sup> (1.5 W/cm<sup>2</sup>)
- Vapor-resistant, flame retardant polypropylene terminal enclosure with 3 ft (.9m) flexible PVC liquid tight conduit
- Optional patented purge feature promotes a longer heater life by reducing chemical permeation
- Lower Watt densities available for highly viscous solutions & technical acids

## Specifications

**Wattages** 3,000 to 18,000 Watts

**Voltages** 120 to 600 Volts. \*600 volt not available on 15 kW to 18 kW.

**Temperature Range** Up to 100°C (212°F)

**Safety Features**

- Grounded internal metal element
- Built-in thermal protector. Replaceable P1 protector standard for up to 82°C (180°F). Other options available
- Non-floating construction

**Certifications** cULus listed  
CE compliant (except 600V)

## Dimensions

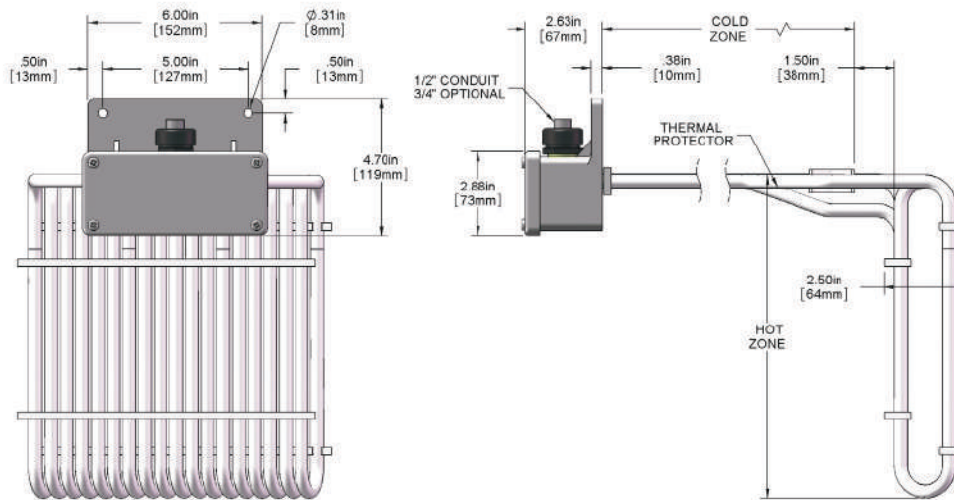

## Model Number Breakdown

Series	Wattage	Voltage	Width	Heater Pad Length	Vertical Length	Phase	Type of Protector	Wire & Conduit Length
3HXOL = PTFE	3 = 3000	1 = 120	08 = 3kW	13 = 3kW	R18	3 phase (std), no designator	<b>Replaceable Fuse</b> P1 (std) = solutions up to 190°F	36" length standard (no designator)
	4.5 = 4500	2 = 240	10.5 = 4.5kW	11 = 4.5kW	Specify custom lengths	1 = single phase	<b>Resettable Fuse</b> P2 = solutions up to 190°F	Specify variations from standard Ex: -X84 = 84"
	6 = 6000	3 = 380	10.5 = 6kW	19 = 6kW			P8 = 190° to 210°F	
	9 = 9000	4 = 480	10.5 = 9kW	23 = 9kW			P3 = 210° to 250°F	
	12 = 12000	5 = 415	10.5 = 12kW	30 = 12kW				
	15 = 15000	6 = 600	10.5 = 15kW	36 = 15kW				
	18 = 18000	7 = 400	10.5 = 18kW	42 = 18kW				
		8 = 208						
		9 = 220						
		0 = 200						