

HXO Series

PRODUCT DATA SHEET

Fluoropolymer Heater

Excellent chemical resistance to aggressive acids!

Inert to most solutions

Low Watt density design saves space & ensures long life

Corrosion-resistant head

Built-in thermal protector & grounded element



Up to 100°C (212°F)



500 to 9,000 Watts



120 to 600 Volts
(600V on 4,500W or lower only)



PTFE sleeved 304 stainless steel



cULus
CE (except 600 Volts)

HXO SERIES, FLUOROPOLYMER (PTFE) HEATERS								
WATTS	VOLTS	WIDTH in/(mm)	HEATER PAD LENGTH in/(mm)	HOT ZONE in/(mm)	OVERALL LENGTH in/(mm)	MAX. COLD ZONE in/(mm)	MODEL NUMBER	SHP WGT. lbs/(kg)
500	120	5	6	8	11	36	HXO.5105-06-11-**-*	6
	240	(127)	(152)	(203)	(279)	(914)	HXO.5205-06-11-**-*	(2.7)
1000	120	6	6	8	11	36	HXO1106-06-11-**-*	7
	240	(152)	(152)	(203)	(279)	(914)	HXO1206-06-11-**-*	(3.2)
2000	120	6	10	12	17	35	HXO2106-10-17-**-*	8
	240	(152)	(254)	(305)	(432)	(889)	HXO2206-10-17-**-*	(3.6)
	480						HXO2406-10-17-**-*	
3000	240	6	12	14	23	35	HXO3206-12-23-**-*	13
	480	(152)	(305)	(356)	(584)	(889)	HXO3406-12-23-**-*	(5.9)
4000	240	6	19	21	29	35	HXO4206-19-29-**-*	15
	480	(152)	(483)	(533)	(737)	(889)	HXO4406-19-29-**-*	(6.8)
5000	240	6	20	22	35	31	HXO5206-20-35-**-*	18
	480	(152)	(508)	(559)	(889)	(787)	HXO5406-20-35-**-*	(8.2)
6000	240	6	22	24	40	25	HXO6206-22-40-**-*	22
	480	(152)	(559)	(610)	(1016)	(635)	HXO6406-22-40-**-*	(10)
8000	240	6	36	38	47	28	2HXO8206-36-47-**-*	25
	480	(152)	(914)	(965)	(1194)	(711)	2HXO8406-36-47-**-*	(11.3)
9000	240	6	40	42	54	30	2HXO9206-40-54-**-*	28
	480	(152)	(1016)	(1067)	(1372)	(762)	2HXO9406-40-54-**-*	(12.7)

Single phase ONLY. Guards recommended.

Features & Values

- Inert to most aqueous acid, alkaline, anodizing, & pickling solutions up to 100°C (212°F)
- Rugged, heavy wall PTFE covered stainless steel element reduces permeation. Guaranteed 100% pinhole free
- Space saving & long service life with low Watt density design of 10 W/in² (1.5 W/cm²)
- Vapor-resistant, flame retardant polypropylene terminal enclosure with 3 ft (.9m) flexible PVC liquid tight conduit
- Optional patented purge feature promotes a longer heater life by reducing chemical permeation
- Lower Watt densities available for highly viscous solutions & technical acids

Specifications

Wattages	500 to 9,000 Watts
Voltages	120 to 600 Volts (600V on 4,500W or lower only)
Temperature Range	Up to 100°C (212°F)
Safety Features	<ul style="list-style-type: none"> ▫ Grounded internal metal element ▫ Built-in thermal protector. Replaceable P1 protector standard for up to 82°C (180°F). Other options available ▫ Non-floating construction
Certifications	cULus listed CE compliant (except 600V)

Dimensions

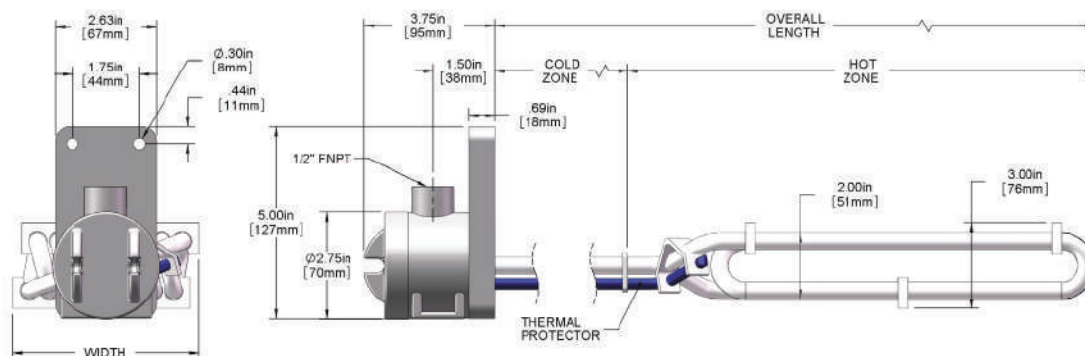

Model Number Breakdown

Series	Wattage	Voltage	Width	Hot Zone	Overall Length	Type of Protector	Wire & Conduit Length
HXO = PTFE	.5 = 500	1 = 120	05 = .5kW	06 = .5kW	11 = .5kW	Replaceable Fuse (Type-JTC)	36" length standard (no designator)
	1 = 1000	2 = 240	06 = 1kW	06 = 1kW	11 = 1kW	P1 (std) = solutions up to 190°F	Specify variations from standard Ex: -X84 = 84"
	2 = 2000	3 = 380	06 = 2kW	10 = 2kW	17 = 2kW	Resettable Fuse (Type-JTC)	
	3 = 3000	4 = 480	06 = 3kW	12 = 3kW	23 = 3kW	P2 = solutions up to 190°F	
	4 = 4000	5 = 415	06 = 4kW	19 = 4kW	29 = 4kW	P8 = 190° to 210°F	
	5 = 5000	6 = 600	06 = 5kW	20 = 5kW	35 = 5kW	P3 = 210° to 250°F	
	6 = 6000	7 = 400	06 = 6kW	22 = 6kW	40 = 6kW		
	8 = 8000	8 = 208	06 = 8kW	36 = 8kW	47 = 8kW		
	9 = 9000	9 = 220	06 = 9kW	40 = 9kW	54 = 9kW		
	0 = 200				Specify custom lengths		