

HXT Series

PRODUCT DATA SHEET

Fluoropolymer Heater

Excellent chemical resistance to aggressive acids!

Inert to most solutions

Low Watt density design saves space & ensures long life

Corrosion-resistant head

Grounded element



Up to 100°C (212°F)



1,000 to 6,000 Watts



120 to 600 Volts
600V on 4,500W or lower only



PTFE sleeved 304 stainless steel



CE (except 600 Volts)

HXT SERIES, FLUOROPOLYMER (PTFE) SCREW PLUG HEATERS					
WATTS	VOLTS	OVERALL LENGTH in/(mm)	PIPE THREAD	MODEL NUMBER	SHIP WGT. lbs/(kg)
1000	120	9	2-1/2	HXT1109	9
	240	(229)	2-1/2	HXT1209	(4.1)
2000	120	14	2-1/2	HXT2114	12
	240	(356)	2-1/2	HXT2214	(5.4)
	480		2-1/2	HXT2414	
3000	240	19	2-1/2	HXT3219	15
	480	(483)	2-1/2	HXT3419	(6.8)
4000	240	26	2-1/2	HXT4226	17
	480	(660)	2-1/2	HXT4426	(7.7)
5000	240	30	2-1/2	HXT5230	20
	480	(762)	2-1/2	HXT5430	(9.1)
6000	240	34	2-1/2	HXT6234	23
	480	(864)	2-1/2	HXT6434	(10.4)

Single phase only.

Features & Values

- Inert to most aqueous acid, alkaline, anodizing, & pickling solutions up to 100°C (212°F)
- Rugged, heavy wall PTFE covered stainless steel element and PVDF screw plug reduces permeation. Guaranteed 100% pinhole free
- Space saving & long service life with low Watt density design of 10 W/in² (1.5 W/cm²)
- Polypropylene terminal enclosure with 3 ft (.9m) flexible PVC liquid tight conduit
- Lower Watt densities available for highly viscous solutions & technical acids

NOTE: Intended for horizontal installation only.

Specifications

Wattages	1,000 to 18,000 Watts
Voltages	120 to 600 Volts (600V on 4,500W or lower only)
Temperature Range	Up to 100°C (212°F)
Safety Features	▫ Grounded internal metal element
Certifications	CE compliant (except 600V)

Dimensions

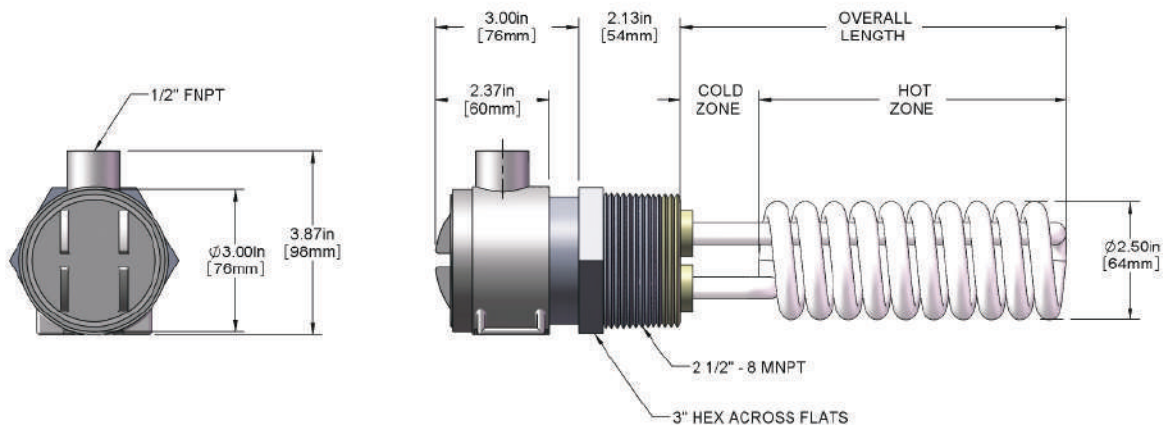

Model Number Breakdown

Series	Wattage	Voltage	Length (in.)	Type of Protector	Wire & Conduit Length
HXT = PTFE	1 = 1000	1 = 120	9 = 1kW	Resettable Fuse (Type-J TC)	36" length standard (no designator)
	2 = 2000	2 = 240	14 = 2kW	P3 (std) = Solutions up to 250°F	Specify variations from standard Ex: -X84 = 84"
	3 = 3000	3 = 380	19 = 3kW		
	4 = 4000	4 = 480	26 = 4kW		
	5 = 5000	5 = 415	30 = 5kW		
	6 = 6000	6 = 600	34 = 6kW		
		7 = 400	Specify custom lengths		
		8 = 208			
		9 = 220			
		0 = 200			