

3V SERIES, TRIPLE METAL DEEP TANK HEATERS							
WATTS	VOLTS	THREE TUBE LENGTH		STEEL	304 SS	316 SS	TITANIUM
		In./	(mm)				
18000	240	36		3VP18236-R*-**	3VF18236-R*-**	3VS18236-R*-**	3VT18236-R*-**
		(914)		3VP18436-R*-**	3VF18436-R*-**	3VS18436-R*-**	3VT18436-R*-**
24000	240	44		3VP24244-R*-**	3VF24244-R*-**	3VS24244-R*-**	3VT24244-R*-**
		(1118)		3VP24444-R*-**	3VF24444-R*-**	3VS24444-R*-**	3VT24444-R*-**
27000	480	50		3VP27450-R*-**	3VF27450-R*-**	3VS27450-R*-**	3VT27450-R*-**
		(1270)					
30000	480	55		3VP30455-R*-**	3VF30455-R*-**	3VS30455-R*-**	3VT30455-R*-**
		(1397)					
36000	480	64		3VP36464-R*-**	3VF36464-R*-**	3VS36464-R*-**	3VT36464-R*-**
		(1626)					
45000	480	77		3VP45477-R*-**	3VF45477-R*-**	3VS45477-R*-**	3VT45477-R*-**
		(1956)					
48000	480	82		3VP48482-R*-**	3VF48482-R*-**	3VS48482-R*-**	3VT48482-R*-**
		(2083)					
54000	480	91		3VP54491-R*-**	3VF54491-R*-**	3VS54491-R*-**	3VT54491-R*-**
		(2311)					

*Specify riser height required. Example: 3VS18236-R59-P2

3V Features and Benefits

SUPERIOR CHEMICAL RESISTANCE:

- ◆ Materials available for use in most aqueous alkaline solutions, plating solutions, and rinse tanks. Check solution recommendation chart or with your chemical supplier for proper sheath material selection.

RUGGED CONSTRUCTION:

- ◆ Heavy wall metal sheaths available in:
 - Plain Steel
 - 304 stainless steel
 - 316 stainless steel
 - Titanium

LONG-LASTING PERFORMANCE:

- ◆ Watt densities of 35 watts per square inch (5.4cm/cm²) ensure long service life.

CORROSION RESISTANT HEAD:

- ◆ Vapor resistant, flame retardant polypropylene terminal enclosure with 3-foot (.9mm) flexible PVC liquid tight conduit.

SAFETY FEATURES:

- ◆ Grounded construction.
- ◆ Thermal protection built in. Resettable P2 protector standard for solutions up to 180°F (82°C).

- ◆ Non-floating construction..

CERTIFICATIONS: cULus listed and CE compliant (except 600 volts).

SIZES:

- ◆ 18,000 watts to 54,000 watts.

VOLTAGES:

- ◆ 240 to 600 volts. Three phase standard, single phase available. Some amperage limitations apply, consult factory.

OPTIONS AVAILABLE (consult factory):

- ◆ Resettable thermal protectors:
 - P6: for solutions from up to 230°F(110°C)
- ◆ Longer vertical lengths (cold zones).
- ◆ Special configurations.
- ◆ Longer wire and conduit lengths.
- ◆ Lower watt densities for highly viscous solutions.
- ◆ Temperature and level controls sized to match the heater.
- ◆ All metal welded junction box.

DIMENSIONS

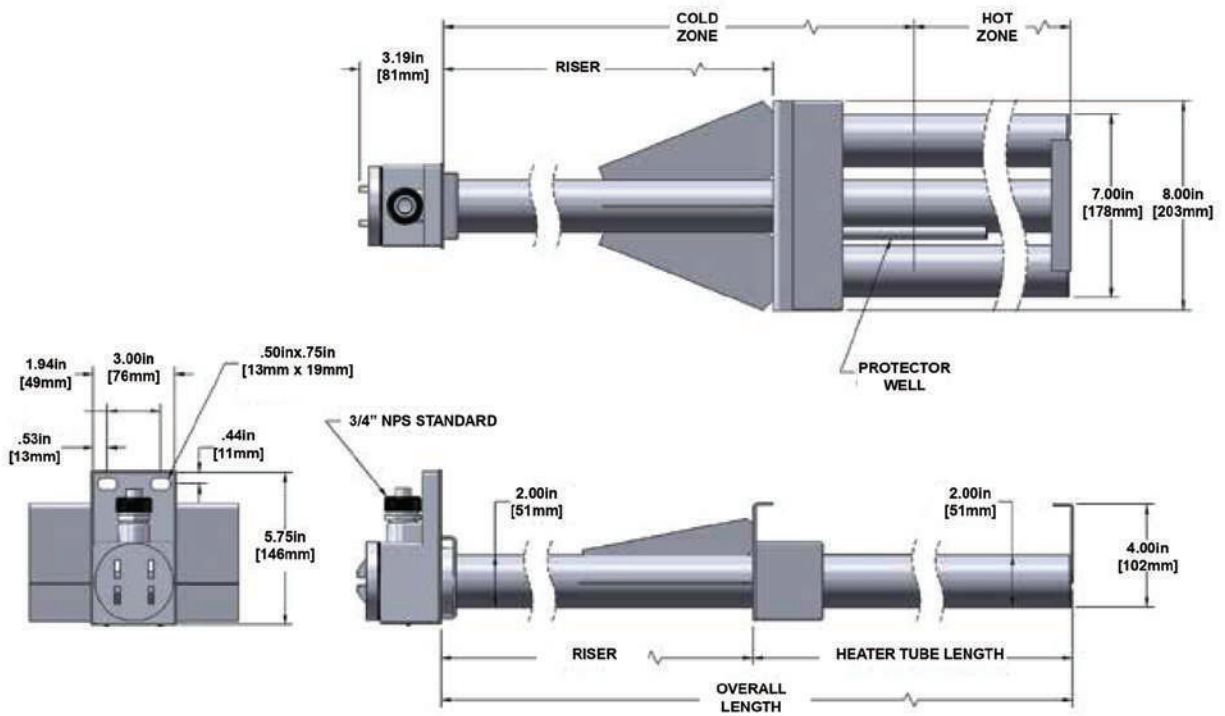

TRIPLE TUBE DEEP TANK METAL OVER THE SIDE HEATER ORDERING INFORMATION

Series	Wattage	Voltage	Heater Tube Length (in.)	Riser Length	Options	Type of Protector	Wire and Conduit Length								
	18 = 18000 24 = 24000 27 = 27000 30 = 30000 36 = 36000 45 = 45000 48 = 48000 54 = 54000	2 = 240 3 = 380 4 = 480 5 = 415 6 = 600 7 = 400 8 = 208 9 = 220 0 = 200	36 = 18kW 44 = 24kW 50 = 27kW 55 = 30kW 64 = 36kW 77 = 45kW 82 = 48kW 91 = 54kW	Specify custom lengths, (so that overall length does not exceed tank depth). Ex: R48=48"			36" conduit length standard (no designator) Specify variations from standard Ex: -X84 = 84"								
	3VP = Plain Steel 3VF = 304 Stainless Steel 3VS = 316 Stainless Steel 3VT = Titanium														
	No designator = 3 phase power (standard) -1 = single phase power														
							<table border="1" style="width: 100%; border-collapse: collapse;"> <thead> <tr> <th colspan="2" style="text-align: center;">Resettable Fuse</th> </tr> <tr> <th colspan="2" style="text-align: center;">(additional control components required)</th> </tr> </thead> <tbody> <tr> <td style="text-align: center;">-P2</td> <td style="text-align: center;">For solutions up to 180°F</td> </tr> <tr> <td style="text-align: center;">-P6</td> <td style="text-align: center;">For 180° - 230°F solutions</td> </tr> </tbody> </table>	Resettable Fuse		(additional control components required)		-P2	For solutions up to 180°F	-P6	For 180° - 230°F solutions
Resettable Fuse															
(additional control components required)															
-P2	For solutions up to 180°F														
-P6	For 180° - 230°F solutions														

ORDERING EXAMPLE:

3VS18436-R59-P2

Triple tube, deep tank, 316 stainless, 18kW, 480 volt, 3 phase, 36" heater tube length, 59" riser, P2 protector.