



# HMP5 Relative Humidity and Temperature Probe

For high temperatures



## Features

- RH accuracy up to  $\pm 0.8$  %RH
- Temperature accuracy up to  $\pm 0.1$  °C ( $\pm 0.18$  °F)
- Temperature measurement range  $-70$  ...  $+180$  °C ( $-94$  ...  $+356$  °F)
- Operating temperature of probe body  $-40$  ...  $+80$  °C ( $-40$  ...  $+176$  °F)
- Sensor purge provides superior chemical resistance
- Modbus® RTU over RS-485
- 250-mm (9.84 in) probe allows easy process installation through insulation
- Compatible with Indigo series transmitters and Insight PC software
- Traceable calibration certificate: 6 points for humidity, 1 point for temperature

Vaisala HUMICAP® Humidity and Temperature Probe HMP5 is designed for high-temperature applications such as baking ovens, pasta dryers, and industrial drying kilns, where measurement performance and chemical tolerance are essential.

### Proven Vaisala HUMICAP® performance

Vaisala is the original innovator of the thin-film capacitive humidity measurement technology, which has now become the industry standard in humidity measurement.

HUMICAP® technology results from Vaisala's 40-year experience in industrial humidity measurement, providing the best stability, fast response time, and low hysteresis in a wide range of applications.

### Chemical purge minimizes effects of contaminants

In environments with high concentrations of chemicals and cleaning agents, the chemical purge option helps to maintain measurement accuracy between calibration intervals.

The chemical purge involves heating the sensor to remove harmful chemicals. The function can be initiated manually or programmed to occur at set intervals.

### Flexible connectivity

The probe is compatible with Vaisala Indigo series transmitters, and it can be used as a standalone digital Modbus RTU transmitter over RS-485 serial bus. For easy-to-use access to field calibration, device analytics, and configuration functionality, the probe can be connected to Vaisala Insight software for Windows®. For more information, see [www.vaisala.com/insight](http://www.vaisala.com/insight).

### Vaisala Indigo product family

Indigo transmitters extend the capabilities of Indigo compatible measurement probes. The transmitters can display measurements on the spot as

well as transmit them to automation systems through analog signals, digital outputs, and relays. Cable length between probe and transmitter can be extended to up to 30 meters. For more information, see [www.vaisala.com/indigo](http://www.vaisala.com/indigo).



DNV GL type approval certificate no. TAA00002YT

# Technical data

## Measurement performance

### Relative humidity

Measurement range	0 ... 100 %RH
Accuracy at +23 °C (+73.4 °F) <sup>1)</sup>	±0.8 %RH (0 ... 90 %RH)
Factory calibration uncertainty <sup>2)</sup>	±0.5 %RH (0 ... 40 %RH) ±0.8 %RH (40 ... 95 %RH)
T <sub>63</sub> response time	15 s
Sensor options	HUMICAP® R2 HUMICAP® R2C <sup>3)</sup>

### Temperature

Measurement range	-70 ... +180 °C (-94 ... +356 °F)
Accuracy at +23 °C (+73.4 °F) <sup>1)</sup>	±0.1 °C (±0.18 °F)
Factory calibration uncertainty <sup>2)</sup>	±0.1 °C (±0.18 °F) at +23 °C (+73.4 °F)
Sensor	Pt100 RTD Class FO.1 IEC 60751

- 1) Defined against calibration reference. Including non-linearity, hysteresis, and repeatability.  
 2) Defined as ±2 standard deviation limits. Small variations possible; see calibration certificate.  
 3) Chemical purge feature available with this sensor.

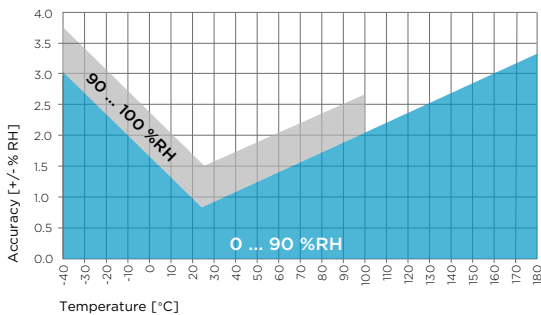

HMP5 humidity measurement accuracy as a function of temperature

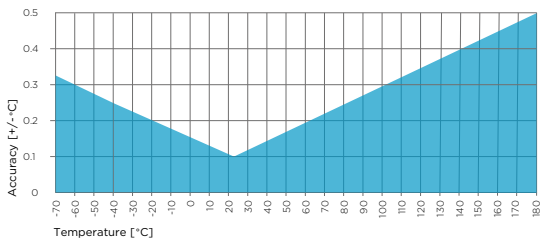

HMP5 temperature measurement accuracy over full range

## Operating environment

Operating temperature of probe body	-40 ... +80 °C (-40 ... +176 °F)
Operating temperature of probe head	-70 ... +180 °C (-94 ... +356 °F)
Operating environment	Suitable for outdoor use
IP rating of probe body	IP66

## Inputs and outputs

Operating voltage	15 ... 30 V DC
Current consumption	10 mA typical, 500 mA max.
Digital output	RS-485, non-isolated
Protocols	Modbus RTU

## Output parameters

Absolute humidity (g/m <sup>3</sup> )	Relative humidity (%RH)
Absolute humidity at NTP (g/m <sup>3</sup> )	Relative humidity (dew/frost) (%RH)
Dew point temperature (°C)	Temperature (°C)
Dew/frost point temperature (°C)	Water concentration (ppm <sub>v</sub> )
Dew/frost point temperature at 1 atm (°C)	Water concentration (wet basis) (vol-%)
Dew point temperature at 1 atm (°C)	Water mass fraction (ppm <sub>w</sub> )
Dew point temperature difference (°C)	Water vapor pressure (hPa)
Enthalpy (kJ/kg)	Water vapor saturation pressure (hPa)
Mixing ratio (g/kg)	Wet-bulb temperature (°C)

## Compliance

EU directives	EMC Directive (2014/30/EU) RoHS Directive (2011/65/EU)
EMC compatibility	EN 61326-1, industrial environment
Type approvals	DNV GL certificate no. TAA00002YT
Compliance marks	CE, China RoHS, RCM, WEEE

## Mechanical specifications

Connector	M12 5-pin A-coded male
Weight	436 g (15.37 oz)
<b>Materials</b>	
Probe	AISI 316L
Probe body	AISI 316L
Cable jacket	FEP

## Accessories

Mounting flange	210696
Indigo USB adapter <sup>1)</sup>	USB2

<sup>1)</sup> Vaisala Insight software for Windows available at [www.vaisala.com/insight](http://www.vaisala.com/insight).

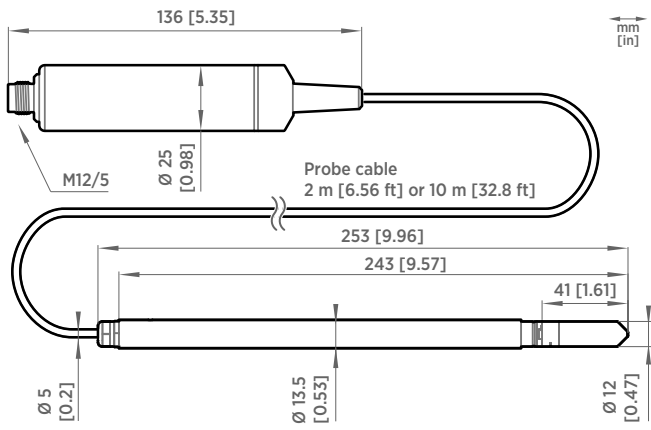

HMP5 probe dimensions

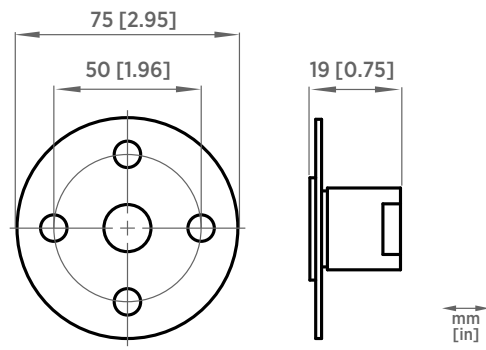

Mounting flange 210696 dimensions

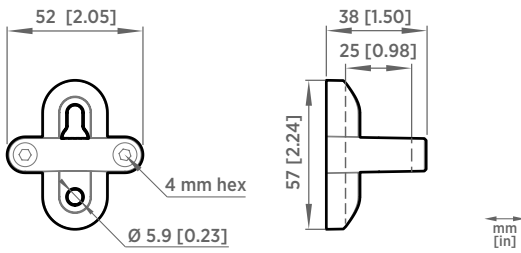

Probe holder ASM213582 dimensions