



Model 265

Low Differential Pressure Transducer

Features

- Excellent price-to-performance ratio
- Reduce installation costs
- $\pm 0.25\%$, $\pm 0.4\%$, $\pm 1\%$ FS accuracy options
- 24 VDC or 24 VAC excitation
- Voltage or analog outputs
- Reverse wiring protection
- Internal regulation
- Fire retardant case (UL 94 V-0 approved)
- CE & RoHS compliant

Applications

- HVAC systems
- Energy management systems
- Variable Air Volume and Fan Control (VAV)
- Environmental pollution control
- Static duct and cleanroom pressures

Setra's Model 265 is a lower price solution that offers an excellent price to performance ratio and meets the requirements in all typical HVAC applications. The 265 is a low differential pressure transducer that uses a dead-ended capacitive sensing element that requires minimal amplification and delivers excellent accuracy and longterm stability. It delivers $\pm 1\%$ FS accuracy with $\pm 0.25\%$ and $\pm 0.5\%$ accuracy options with pressure ranges from 0.25" W.C. up to 100" W.C. The 265 has a small footprint, an AC power option and an optional conduit cover that allows for simple, secure installation for any applications.

The best price-to-performance in the industry

The 265 delivers exceptional features at a low price, perfect for any OEM looking for quality and performance at an affordable price.

Quick and easy installation

The 265 is designed to reduce installation costs while increasing overall operating efficiency. Installation is easy with integral mounting tabs, pressure connections located on the face of the unit, and a screw terminal strip for electrical termination.

The Setra sensor

The core technology of the 265 is the all stainless steel capacitive sensing element. Setra designs and manufactures all of their sensing elements resulting in full control over the process and quality of every single sensor. The welded dead-ended capacitive sensors requires minimal amplification and delivers excellent accuracy and longterm stability. Setra's technology has been used in over 8 million installations and has the highest field acceptance rate in the industry.

Specifications

Performance data

Accuracy RSS¹ (at constant temp)	±1.0% FS (standard); ±0.4% FS, ±0.25% FS (optional)
Non-linearity, BFSL	±0.98% FS (standard); ±0.38% FS, ±0.22% FS (optional)
Hysteresis	0.10% FS
Non-repeatability	0.05% FS

Thermal effects²

Compensated range °F (°C)	0 to +150 (-18 to +65)
Zero shift %FS/100°F(50°C)	±0.033 (±0.06)
Span shift %FS/100°F(50°C)	±0.033 (±0.06)
Max. line pressure	10 PSI
Overpressure	Up to 10 PSI (range dependent)
Long term stability	0.5% FS/YR
Warm-up shift	±0.1% FS Total

Environmental data

Operating temperature °F (°C)³	0 to +150 (-18 to +65)
Storage temperature °F (°C)	-40 to +185 (-40 to +85)

Pressure media

Clean air or similar non-conducting gases.

¹ RSS of Non-Linearity, Non-Repeatability and Hysteresis
² Units calibrated at nominal 70°F. Maximum thermal error computed from this datum.
³ Operating temperature of the electronics only. Pressure media temperatures may be considerably higher or lower.
⁴ Unit is factory calibrated at 0g effect of vertical position.
⁵ Calibrated into 50K ohm load. Operable into 5000 ohms or greater.
⁶ Zero & Span (FS) output factory set to within ±50mV (±25 mV for optional accuracies).
⁷ Calibrated at factory with a 24 VDC loop supply voltage and a 250 ohm load.
⁸ Zero & Span (FS) output factory set to within ±0.16 mA (±0.08 mA for optional accuracies.).

Physical description

Pressure Fittings	1/4" Fitting
Case	Fire Retardant Glass Filled Polyester (UL 94-V Approved)
Weight	3 oz
Elec. Connection	Screw terminal strip

Position effect⁴

Range	Zero offset (%FS/G)
0 to 0.5" W.C.	0.60
0 to 1.0"W.C.	0.50
0 to 2.5"W.C.	0.22
0 to 5.0"W.C.	0.14

Electrical data (voltage)

Circuit	3-Wire (Com, Out, Exc)
Excitation/output⁵	9 to 30 VDC / 0 to 5 VDC ⁶ 9 to 30 VAC / 0 to 5 VDC 12 to 30 VAC / 0 to 10 VDC ⁶
Output impedance	<100 ohms
Bidirectional output at zero pressure	2.5 VDC (±50 mV)

Electrical data (current)

Circuit	2-wire
Output⁷	4 to 20 mA ⁸
External load	0 to 800 ohms
Min. loop supply voltage (VDC)	9 + 0.02 x (resistance of receiver plus line)
Max. loop supply voltage (VDC)	30 + 0.004 x (resistance of receiver plus line)
Bidirectional output at zero pressure	12 mA

NOTE: Setra quality standards are based on ANSI-Z540-1. The calibration of this product is NIST traceable.

Specifications subject to change without notice.

U.S. Patent Nos. 5442962, 6019002, and other Patents Pending.

Ordering information

Example part number: 26512R5WD11T1C; Model 265, 0 to 25 in. WC Range, 4 to 20 mA Output, Terminal Strip Electrical Connection, ±1% Accuracy.

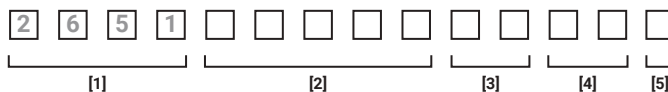

[1]	[2]	[2]	[3]	[4]	[5]
Model	Unidirectional ranges	Bidirectional ranges	Excitation/output	Electrical termination	Accuracy¹
2651 Model 265	R25WD 0 to 0.25" W.C. 0R5WD 0 to 0.5" W.C. 001WD 0 to 1" W.C. 2R5WD 0 to 2.5" W.C. 005WD 0 to 5" W.C. 010WD 0 to 10" W.C. 025WD 0 to 25" W.C. 050WD 0 to 50" W.C. 100WD 0 to 100" W.C. 025LD 0 to 25 Pa 050LD 0 to 50 Pa 100LD 0 to 100 Pa 250LD 0 to 250 Pa 500LD 0 to 500 Pa 10CLD 0 to 1000 Pa	0R1WB ±0.1" W.C. R25WB ±0.25" W.C. 0R5WB ±0.5" W.C. 001WB ±1" W.C. 2R5WB ±2.5" W.C. 005WB ±5" W.C. 010WB ±10" W.C. 025WB ±25" W.C. 050WB ±50" W.C. 025LB ±25 Pa 050LB ±50 Pa 100LB ±100 Pa 250LB ±250 Pa 500LB ±500 Pa 10CLB ±1000 Pa	11 24 VDC / 4 to 20 mA 2B 24 VDC / 0 to 5 VDC AB 24 VAC / 0 to 5 VDC AC 24 VAC / 0 to 10 VDC	T1 Terminal strip A1 1/2" conduit enc.	C ±1% FS E ±0.4% FS F ±0.25% FS G ±1% FS

¹ Optional accuracy codes E, F, G, include calibration certificate.

Contact Setra for versions not shown here.

Dimensions

Electrical termination
"T1"

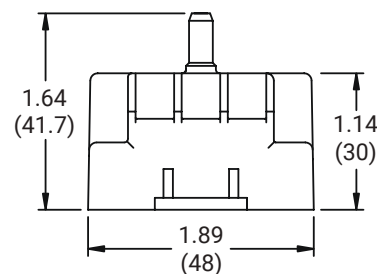
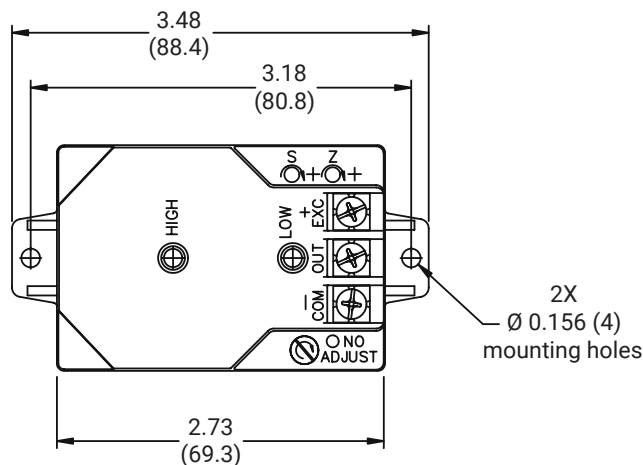

Electrical termination
"A1"

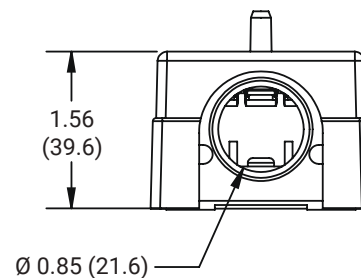
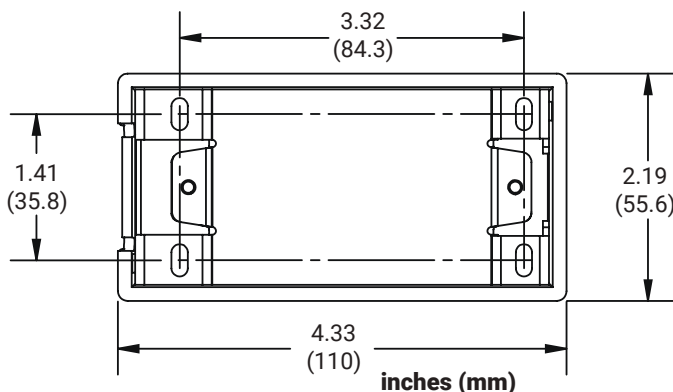

SSP 265 Rev. K.01/2019