

Model MR1 & MR2

MultiSense™

Pressure Transducer

The Setra Model MR1 and MR2 are Setra's newest differential pressure transducer. The Setra MR1/MR2 is the ideal product for any contractor, combining the flexibility of a multi-range with the performance of a single range sensor. The MR1 and MR2 both have 8 selectable ranges and 3 selectable outputs, easily adjustable on the job with a flip of a switch or jumper. The MR1/MR2 uses an IP67/NEMA 4 rated housing and has a conduit fitting for easy wiring, making the MR1/MR2 an ideal solution for any general HVAC application.

Multi-Configurable

The Setra MR1/MR2 design gives the user total flexibility to make changes on the job site. The user has the option to choose the field configurable range, mounting (wall mount, duct mount or DIN Rail), output (mA or Volt) and engineering unit (W.C. or Pascals). This flexibility means that the contractor can use the MR1/MR2 for all of their needs.

8 Field Selectable Ranges

The Setra MR1/MR2 provides 8 field selectable ranges for MR1 (0.1, 0.25, 0.5 and 1.0"W.C.) and 8 for MR2 (1.0, 2.5, 5.0 and 10"W.C.). These ranges can be selected on site by flipping the jumper to the desired range.

IP67/NEMA 4 Rated Housing

The MR1/MR2 housing is a robust IP67/NEMA 4 rated design and is sealed with a gasket to make it wash-down capable for difficult applications. The MR1/MR2 also has a conduit fitting that makes installation and wiring easier.

Capacitive Sensing Technology

Only Setra can claim ownership to the stainless steel capacitive design used in all of our HVAC/R sensors. Our advanced capacitive element provides excellent stability and linearity, while standing above the competitors in our ability to measure low pressure (<0.0001"W.C.) at high accuracy. Our technology has been used in over 8 million installations and has the highest field acceptance rate in the industry.



- Multi-Configurable
- IP67/NEMA 4 Rated Housing
- Field Selectable

Model MR1/MR2 Features:

- Field Configurable Duct Probe
- 4 Digit LCD
- Field Selectable Range
- Field Selectable Output
- Simple 5-Step Setup
- Field Accessible Push-Button Zero & Span
- Unregulated AC/DC Operation

Target Uses:

- Sub-Contractors- Quick Installation
- Flexible for Building Specification Changes
- Service/Retrofit Friendly
- Service Technicians- Quick & Accurate Reconfiguration

Model MR1 & MR2

MultiSense™ Pressure Transducer



ORDERING INFORMATION

M R -

Field Selectable Ranges								Configuration		Electrical Fitting	
MR1				MR2				S	Standard (Base Mount)	A	1/2" Conduit
Unidirectional Pressure Ranges		Bidirectional Pressure Ranges		Unidirectional Pressure Ranges		Bidirectional Pressure Ranges		U	Universal ¹	P	PG9
0.1"W.C.	25 Pa	±0.1"W.C.	±25 Pa	1.0"W.C.	250 Pa	±1.0"W.C.	±250 Pa	D	DIN Rail	C	1/2" Conduit W/ Cal Certification ²
0.25"W.C.	50 Pa	±0.25"W.C.	±50 Pa	2.5"W.C.	500 Pa	±2.5"W.C.	±500 Pa	P	Duct Probe	D	PG9 W/ Cal Certification ²
0.5"W.C.	100 Pa	±0.5"W.C.	±100 Pa	5.0"W.C.	1,000 Pa	±5.0"W.C.	±1,000 Pa				
1.0"W.C.	250 Pa	±1.0"W.C.	±250 Pa	10"W.C.	2,500 Pa	±10"W.C.	2,500 Pa				

¹Code U, Universal unit includes Duct Probe and DIN Rail options.

²Calibration is performed at highest range.

Ordering Example: MR1UA = Model MR1, Universal Configuration, with 1/2" Conduit.

DIMENSIONS

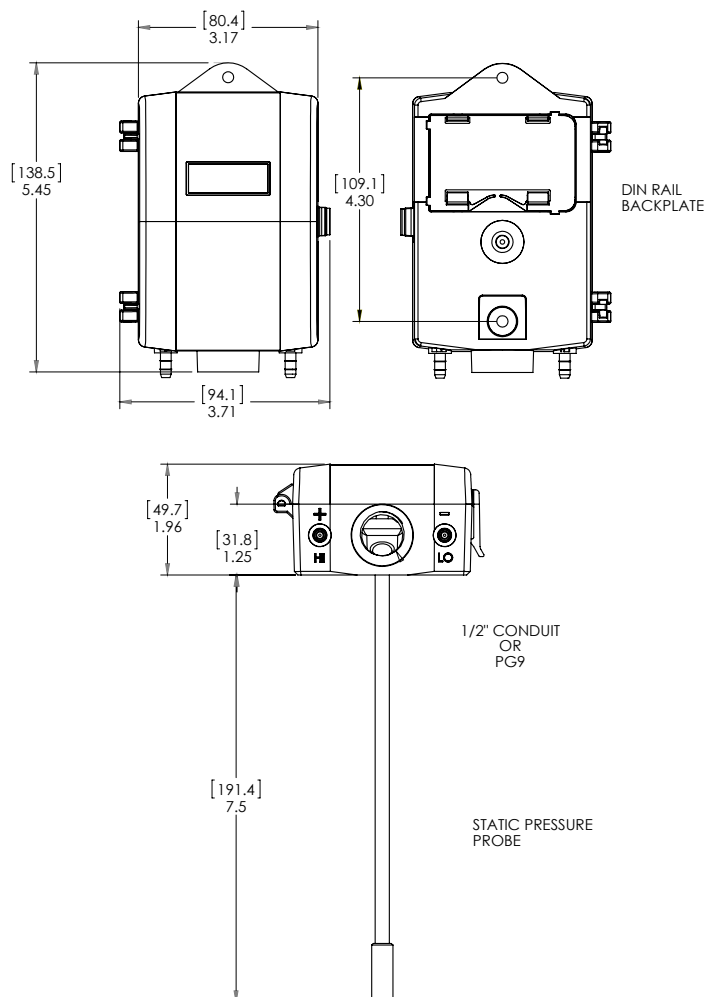

GENERAL SPECIFICATIONS

Performance Data		Environmental Data	
	Standard	Operating Temperature ³	32 to 122°F (0 to 50°C)
Accuracy RSS ¹ (at constant temp)	±1.0% FS	Electrical Data	
Compensated Range °F (°C)	32 to 122°F (0 to 50°C)	Excitation Range	13 to 30 VDC/18 to 24 VAC (Voltage Output) 13 to 30 VDC (4 to 20mA output at terminals)
Thermal Effects ² %FS/°F(°C)	0.03 (0.054)	Current Consumption	30mA (max)
Maximum Line Pressure	10 PSI	Mis-Wiring	Reverse Excitation Protection
Overpressure	Up to 10 PSI (range dependent)	Field Selectable Output ⁴	0 to 5 V, 0 to 10V (3-wire), 4 to 20mA (2-wire)
Long Term Stability (max.)	2.0% FS/YR	Output Resistance (Voltage Output)	10 Ohms (max)
Position Effect		Load Resistance (Voltage Output)	10 K-Ohms (min)
Zero Offset %FS/G	0.5%	Loop Resistance (4-20mA)	0 to 800 Ohms
(Unit is factory calibrated at 0g effect in the vertical position)		Approval	CE & RoHS Compliant
Physical Description		Pressure Media	
Case	Fire-Retardant Polycarbonate (UL 94 V-0 Approved), Hinged Lid	Typically air or similar non-conducting gases.	
Mounting	Two Screw Holes Vertical Position	¹ RSS of Non-Linearity, Hysteresis, and Non-Repeatability.	
Electrical Connection Block	Removable Screw Terminal	² Units calibrated at nominal 70°F. Maximum thermal error computed from this datum.	
Pressure Fitting	3/16" O.D. Barbed Brass	³ Operating temperature limits of the electronics only. Pressure media temperatures may be considerably higher.	
Zero	Push Button	⁴ Calibrated into a 50K ohm load, operable into a 10K ohm load or greater.	
Span	Push Button	⁵ Span (Full Scale) output factory set to within 1%.	
Weight (approx.)	8 Ounces	⁶ Calibrated at factory with a 24VDC loop supply voltage and a 250 ohm load.	
		⁷ Span (Full Scale) output factory set to within ±0.16mA.	
Specifications subject to change without notice.			