



KW320 3 Channel Power Meter, 0.2 Class, Multiple Communication Protocols

The KW320 meter combines high performance with ease of integration to provide a power and energy monitoring solution with 400 metering parameters. The KW320 series multifunction digital power meter is designed using modern MCU and DSP technology and its tamper-proof design is approved for revenue applications. It integrates three-phase energy measuring and displaying, energy accumulating, power quality analysis, malfunction alarming, data logging and network communication. The meter measures bidirectional, four quadrants kWh and kvarh. It provides maximum/minimum records for power usage and power demand parameters. All power and energy parameters can be viewed remotely via Accuview Utility Software to monitor various parameters. The meter comes standard to be mounted in a 4" Round or an IEC 92mm DIN Square form or has the flexibility to be mounted to 35mm DIN rail with the AXM-DIN adapter (See

Accessories Ordering). In addition, the KW320 also has an optional upgrade that includes a NEMA 4X panel enclosure, pre-wired and labeled terminal for CT's, terminal blocks for voltage input, and industrial grade fuses. The KW320-P1-D-W-RC-PC and KW320-P1-D-W-SC-PC optional upgrade is an all-in-one Plug n' play Pre-Wired Panel Enclosure that provides a perfect solution for retrofit projects where metering space is not pre-designed in an electrical distribution panel. The meter supports user selectable RS-485 serial Modbus-RTU, BACNet™ MS/TP, multiple Ethernet communication protocols, and pulse output communication allows seamless integration with data acquisition systems. This product provides demand measurement of Current, Active Power, Reactive Power and Apparent Power – see table 1 for all parameters monitored and metered. It also provides demand forecasting as well as the peak demand. The KW320 series meter can record the time and event regarding important parameter events such as the run time of the meter and alarm functions. Current input options are compatible with any 333mV CT or Flexible Rogowski Coil. Meters come standard with a three channel CT input to accurately measure neutral current. CTs are sold separately as shown on the ACI Split-Core, Solid-Core and Rogowski Current Transformer product data sheets.

Applications: Tenant Billing, Data Centers, Sub-Metering Electrical Panel, Equipment Load Monitoring, Industrial Applications, Predicted Maintenance, Renewable Energy, Overhead Cost Reduction, "NET ZERO" Buildings, LEED Buildings, Green Buildings, and Refrigeration

The KW320 Power Meters are covered by ACI's Five (5) Year Limited Warranty. The warranty can be found in the front of ACI's Sensors & Transmitters catalog, as well as on ACI's web site, workaci.com.

PRODUCT SPECIFICATIONS

Service Type:	Single Phase, 3 Phase – Four Wire (WYE), Three Phase – Three Wire (Delta)
Power¹:	100 - 415VAC, 50/60Hz, 100 - 300VDC on terminals L and N
Burden:	5W
Withstand:	3250VAC, 50/60Hz for 1 minute
Power Supply Wiring:	AWG22-16 (0.6-1.5mm ²)
AC Fuse Protection:	External 1A/250VAC Fuse (Recommended)
Rated Voltage:	100-400VAC Line to Neutral (L-N) or 100-690VAC Line to Line (L-L) RMS for three phase or 100-400VAC RMS for single phase
Number of CT Inputs:	3
Revenue Grade Accuracy:	Active Energy - Class 0.2s (According to IEC 62053-22) and Class 0.2s (According to ANSI C12.20) Reactive Energy - Class 2 (According to IEC 62053-23) – See Table 2 for parameter accuracy, resolution, and range
Voltage Channels:	400 Volts AC (L-N), 690 VAC (L-L), 45Hz - 65Hz, 300Hz - 500Hz
Withstand Voltage:	1500VAC Continuous, 2500VAC, 50/60Hz for 1 Minute
Input Impedance:	2M ohm per Phase
Pickup Voltage:	10VAC
Current Channels:	3 Channels, 0.400 VAC max, 333 mV CTs or 0 to 6000 Amps with Rogowski Coils
Maximum Current Input:	120% of current sensor rating (mV CTs) to maintain accuracy. Up to 6000 Amps w/ Rogowski Coils
Harmonic Resolution:	63rd Harmonic (50Hz or 60Hz type) or 15th Harmonic (400Hz type)
Measurement Type:	Real-time, True RMS measurement of instantaneous Voltage, Current, Power, Frequency, Harmonics, Phase Angle, Demand, Unbalance Factor, Running Time, and Power Factor
Line Frequency:	50/60 Hz
Measurement Data Parameters:	See Table 1
Real Time Parameter Update Rate:	100 mS
Accumulated Parameter Update Rate:	1 Sec
LCD Display:	Multiple Display Modes (Important Parameter's, All Parameter's, Settings Display Modes)
Energy Pulse Output:	Two-wire pulse train, Isolation Voltage 2500 VAC, 0-250 VAC/VDC Load Voltage, 100 mA Max Load Current, Pulse Width 20~100ms, Pulse Constant 1~60,000
Energy Pulse Power Supply:	External 24 VDC Power Supply (Required) Note: 1K Ohm External Current Limiting Resistor (Recommended)

CURRENT | POWER METERS

PRODUCT SPECIFICATIONS *(Continued)*

Communication Protocols:	Serial RS-485: Modbus RTU and BACnet MS/TP Ethernet: BACnet™ Over IP, IEC 61850, Modbus®-TCP, HTTP/HTTPs Webserver, SMTP Email, SNMP, HTTP/HTTPs Push, FTP Post, sFTP Server, WiFi
Maximum Distance:	1200 meters (3,937 Feet) with data range of 100K bits/second or less
Termination Resistor:	120 Ohm to 300 Ohm 1/4W Resistor <i>(Not Included); (Installed at end of RS-485 Comm Bus)</i>
Supported Baud Rates:	BACnet MS/TP Protocol: 9600, 19200, 38400, 76800 Baud Rate (38400 BACnet Default) Modbus RTU Protocol: 1200, 2400, 4800, 9600, 19200, 38400 Baud Rate (19200 Modbus Default)
Max Station:	127 MS/TP Masters (MAC Addresses is 0 to 127)
BACnet Device Instance Number:	1 <i>(Default); Field adjustable from 1 to 4194302</i>
Modbus Data Bits / Parity / Stop Bit	8 / None, Even, Odd / 2, 1
Datalogging Storage:	8 GB
Enclosure Material / Flammability Rating:	Polycarbonate / UL 94V-0
Operating Temperature Range:	-13 to 158°F (-25 to 70°C)
Storage Temperature Range:	-40 to 185°F (-40 to 85°C)
Operating / Storage Humidity Range:	5 to 95%, non-condensing
Wiring Connections:	Screw Connections
Wire Size:	14-22 AWG (2.5 to 0.34 mm ²)
Mounting:	ANSI C39.1 (4" Round) or an IEC 92mm DIN (Square) form.
Utility Software:	Acuview Utility Software, Windows Based; <i>(USB-RS485 converter is required to connect to computer)</i>
Agency Approvals:	BTL Certified, CE, RoHS2, cULus Listed (File # E359521)
Standard Compliance:	Measurement Standard: IEC 62053-22; ANSI C12.20 Environmental Standard: IEC 60068-2 Safety Standard: IEC 61010-1, UL 61010-1, IEC 61557-12 EMC Standard: IEC 61000-4/-2-3-4-5-6-8-11, CISPR 22, IEC 61000-3-2, IEC 61000-6-2/4 Outlines Standard: DIN 43700, ANSI C39.1
Face Dimensions (L x W x H):	3.80" (96 mm) x 3.80" (96 mm) x 1.99" (50.7 mm)
Power Meter Weight:	0.77 lbs. (350g)
KW320 Panel Upgrade <i>(Optional)</i>	
NEMA Rating:	NEMA 4X
Enclosure Material:	Polycarbonate
Fuse:	600 VAC/1A
Wiring:	Two pluggable pre-cut holes to feed wiring, fused terminal blocks for voltage connections pre-installed, color-coded and labelled
Flammability Rating:	94-V0
Enclosure Dimensions (L x W x H):	7.88" (200 mm) x 11.81" (300 mm) x 7.34" (186.5 mm)
Enclosure Product Weight:	8 lbs. (3.63 kg)

Note 1: A power supply can be an independent power supply and a fuse (typical 1A/250Vac) is suggested to be used when connecting the power supply to the meter.

CURRENT | POWER METERS

TABLE # 1

CATEGORY		ITEM	Parameters
Metering	Real time metering	Phase Voltage	V1, V2, V3, Vlnavg
		Line Voltage	V12, V23, V31, Vllavg
		Current	I1, I2, I3, In, Iavg
		Power	P1, P2, P3, Psum
		Reactive Power	Q1, Q2, Q3, Qsum
		Apparent Power	S1, S2, S3, Ssum
		Power Factor	PF1, PF2, PF3, PF
		Frequency	F
		Load Features	Load Features
		Four Quadrant Powers	Four Quadrant Powers
	Energy & demand	Energy	Ep_imp, Ep_exp, Ep_total, Ep_net, Epa_imp, Epa_exp, Epb_imp, Epb_exp, Epc_imp, Epc_exp
		Reactive Energy	Eq_imp, Eq_exp, Eq_total, Eq_net, Eqa_imp, Eqa_exp, Eqb_imp, Eqb_exp, Eqc_imp, Eqc_exp
		Apparent Energy	Es, Esa, Esb, Esc
		Demand	Dmd_P, Dmd_Q, Dmd_S, Dmd_I1, Dmd_I2, Dmd_I3
Monitoring	Power quality	Voltage Unbalance Factor	U_unbl
		Current Unbalance Factor	I_unbl
		Voltage THD	THD_V1, THD_V2, THD_V3, THD_Vavg
		Current THD	THD_I1, THD_I2, THD_I, THD_Iavg
		Individual Harmonics	Harmonics 2nd to 63rd (50H or 60Hz) Harmonics 2nd to 15th (400Hz)
		Voltage Crest Factor	Crest Factor
		TIF	THFF
	Statistics	MAX with Time Stamp MIN with Time Stamp	Each phase of V & I; Total of P, Q, S, PF & F; Demand of I1, I2, I3, P, Q&S; Each phase THD of V & I; Unbalance factor of V & I
Others	Alarm	Over/Under Limit Alarm	V, I, P, Q, S, PF, V_THD & I_THD Each Phase and Total or Average; Unbalance Factor of V & I; Load Type; Analog Input of Each Channel; Demand of I1, I2, I3, P, Q&S; Reverse phase sequence; DI1~DI28
	Power quality event logging (KW320Q model only)	Sag/Dips, Swell	Voltage
	Onboard memory size	Memory	8GB on all 8 models
	Communication	RS485 Port, Half Duplex, Optical Isolated	Modbus®-RTU Protocol
	Time	Real Time Clock	Year, Month, Date, Hour, Minute, Second

CURRENT | POWER METERS

TABLE #2

METERING				
Parameters		Accuracy	Resolution	Range
Voltage		0.2%	0.1V	10V~1000kV
Current		0.2%	0.001A	5mA~50000A
Power		0.2%	1W	-9999MW~9999MW
Reactive Power		0.2%	1var	-9999Mvar~9999Mvar
Apparent Power		0.2%	1VA	0~9999MVA
Power Demand		0.2%	1W	-9999MW~9999MW
Reactive Power Demand		0.2%	1var	-9999Mvar~9999Mvar
Apparent Power Demand		0.2%	1VA	0~9999MVA
Power Factor		0.2%	0.001	-1.000~1.000
Frequency		0.02%	0.01Hz	45.00~65.00Hz (50 or 60Hz type) 300.00Hz~500.00Hz (400Hz type)
Energy	Primary	0.2%	0.1kWh	0-99999999.9kWh
	Secondary	0.2%	0.001kWh	0-999999.999kWh
Reactive Energy	Primary	0.2%	0.1kvarh	0-99999999.9kvarh
	Secondary	0.2%	0.001kvarh	0-999999.999kvarh
Apparent Energy	Primary	0.2%	0.1kVAh	0-99999999.9kVAh
	Secondary	0.2%	0.001kVAh	0-999999.999kVAh
Harmonics		2.0%	0.1%	
Phase Angle		2.0%	0.1°	0.0°~359.9°
Unbalance Factor		2.0%	0.1%	0.0%~100.0%
Running Time			0.01h	0~9999999.99h

CURRENT | POWER METERS

DIMENSIONAL DRAWING

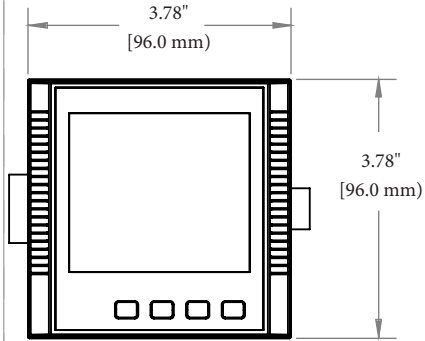

FRONT VIEW

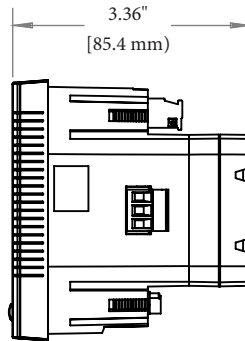

SIDE VIEW

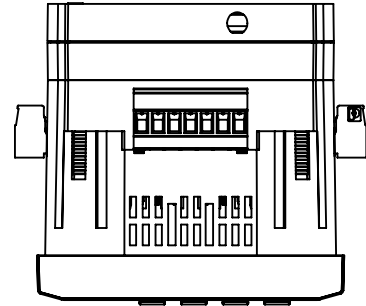

TOP VIEW

DIMENSIONAL DRAWING POWER METER PANEL UPGRADE

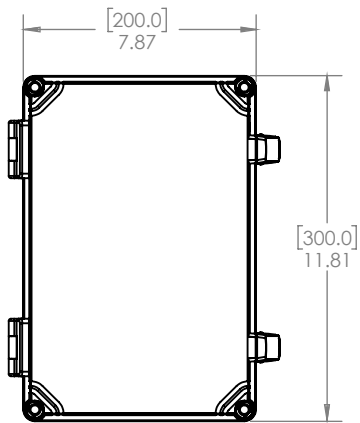

FRONT VIEW

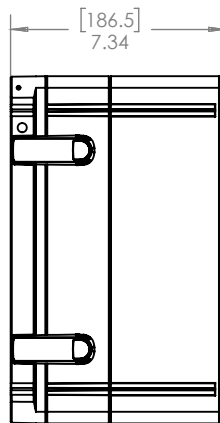

SIDE VIEW

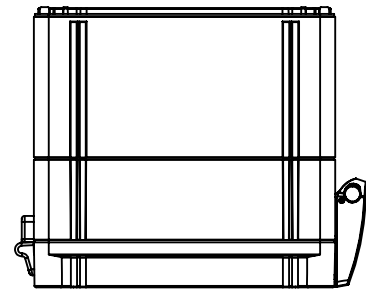

TOP VIEW

CURRENT | POWER METERS

STANDARD ORDERING						
Model #	Item #	mV CT Input	Rogowski Coil Input	Meter Only	Panel Upgrade	Waveform Capture
KW320-P1-D-W-RC-XX	148244		•	•		
KW320-P1-D-W-SC-XX	148245	•		•		
KW320-P1-D-W-RC-PC	148246		•		•	
KW320-P1-D-W-SC-PC	148247	•			•	
KW320Q-P1-D-W-RC-XX	148250		•	•		•
KW320Q-P1-D-W-SC-XX	148249	•		•		•
KW320Q-P1-D-W-RC-PC	148251		•		•	•
KW320Q-P1-D-W-SC-PC	148257	•			•	•

ACCESSORIES ORDERING		
Model #	Item #	Description
AXM-DIN	148248	KW320 DIN Rail Adapter
USB-RS485	148243	RS485 to USB Converter
AK-03	150827	Three Fuse Pack; Inline Fuse Kit; 600V, 2A; Slow Blow