



CURRENT TRANSFORMERS

Standard Grade CTs

The Split Core Current Transformers are designed to convert an AC operating current into a low voltage AC signal for use with microprocessor based circuits that require maximum accuracy and precision. All of the Split Core CTs come standard unterminated with ferrules for easy connection to any of the Single or 3 Phase Dent power meters. Any of the split core CTs can be used with any of the Powerscout™ PS3037, PS24, PS12HD, PS48HD Power Meters in applications where typical power measurements are required and reduced accuracies are acceptable. Where higher accuracies are required, refer to the Revenue Grade CTs product data sheet for more detailed product information. For best accuracy, the CTs should be selected based upon the size of the conductors to be monitored by selecting the proper window size and using the expected maximum and minimum currents expected for the piece of equipment

or branch circuit. The acceptable Measurement Current Range is referenced in ordering grid table on the back of the product data sheet. The CT-SCM and CT-SCL Series Current transformers are a cost effective alternative to the Rocoil™ CTs but overall selection should be based upon the maximum and minimum currents being monitored. All currents below the minimum measurement range will cause a “Snap to Zero” to occur which means that the power meter will show that no current is being consumed at that time thus affecting the reliability of your data. Flexible Rocoil™ CTs provide a higher level of accuracy and should be used in applications with current levels of 600 Amps and larger. The CT-HSC and CT-HMC Series current transformers come with a snap acting hinged design are designed to provide great performance, lower operating currents and easy installation in both new and retrofit installations. Extending the leads on all of the Split Core CTs can be done in the field when using the same style and type of wire that is provided with the CTs as discussed in the Current Transformer Lead Extension Whitepaper or ordered from the factory for an additional cost and lead time.

Applications: Energy and Demand Metering, Load Surveys, LEED/Green Projects, ROI / Project Justification

The Split Core mV Output Current Transformers are covered by ACI's One (1) Year Limited Warranty. The warranty can be found in the front of ACI's Sensors & Transmitters catalog, as well as on ACI's website, www.workaci.com.

PRODUCT SPECIFICATIONS

Monitored Current Type:	AC Current
Maximum Working Voltage:	600 VAC, Category III
Core Style:	Split-Core (See Ordering Grid)
Dielectric Strength:	CT-HSC Series: 3520 VAC for 1 minute CT-HMC Series: 5200 VAC for 1 Minute CT-SCS, CT-SCM & CT-SCL Series: 5000 VAC Around Case
Operating Frequency Range:	50 to 400 Hz
Sensor Amperage Range:	See Ordering Grid
Output Signal:	See Ordering Grid
Accuracy Ratio Error %:	See Ordering Grid
Phase Error:	See Ordering Grid
Phasing Orientation:	CT-Rxx-A4-U Series: Arrow points towards load All Others: Label points toward the source
Operating Temperature Range:	CT-HSC & CT-HMC Series: 5 to 140°F (-15 to 60°C) CT-SCS, CT-SCM & CT-SCL Series: -4 to 131°F (-20 to 55°C)
Storage Temperature Range:	CT-HSC and CT-HMC Series: -4 to 185°F (-20 to 85°C)
Operating Storage Humidity Range:	5 to 95%, non-condensing
Case Material Flammability Rating:	CT-HSC & CT-HMC Series: White Nylon UL 94V-0 CT-SCS, CT-SCM & CT-SCL Series: Epoxy Encapsulated Housing
Wiring Connections:	Unterminated with Ferrules
Lead Wire Colors:	White = Positive (+) Black = Negative (-) (Polarity Sensitive)
Wire Size Lead Length:	20 AWG (0.823 mm ²), 600V Rated VW-1, 105°C Black/White Twisted Pair (UL 1015) 9.84' (3.0m)
Agency Approvals:	CE, RoHS2, WEEE, ISO 9001:2008 CT-HSC & CT-HMC Series: Designed to UL Standard 61010-1 (UL File# E186827); CAN/CSA STD C22.2 No. 61010-1 CT-SCS, CT-SCM & CT-SCL Series: Conforms to UL Standard 61010-1 EN-60044-1 (ETL File# 3101607) CAN/CSA STD C22.2 No. 61010-1
Product Weight:	CT-HSC Series: 0.250 lbs. (0.114 kg) CT-HMC Series: 0.550 lbs. (0.250 kg) CT-SCS Series: 0.300 (0.136 kg) CT-SCM Series: 0.800 lbs. (0.363 kg) CT-SCL Series: 1.8 lbs. (0.837 kg)
Product Dimensions (L x W x H):	CT-HSC Series: 1.64" (41.66 mm) x 1.16" (29.47 mm) x 1.04" (26.42 mm) CT-HMC Series: 2.76" (70.11 mm) x 2.00" (50.80 mm) x 1.52" (38.61 mm) CT-SCS Series: 2.00" (50.80 mm) x 2.10" (53.34 mm) x 0.60" (15.24 mm) CT-SCM Series: 3.25" (82.55 mm) x 3.35" (85.09 mm) x 1.00" (25.40 mm) CT-SCL Series: 4.80" (121.9 mm) x 5.00" (127.00 mm) x 1.20" (30.48 mm)

CURRENT | POWER METER | CURRENT TRANSFORMERS

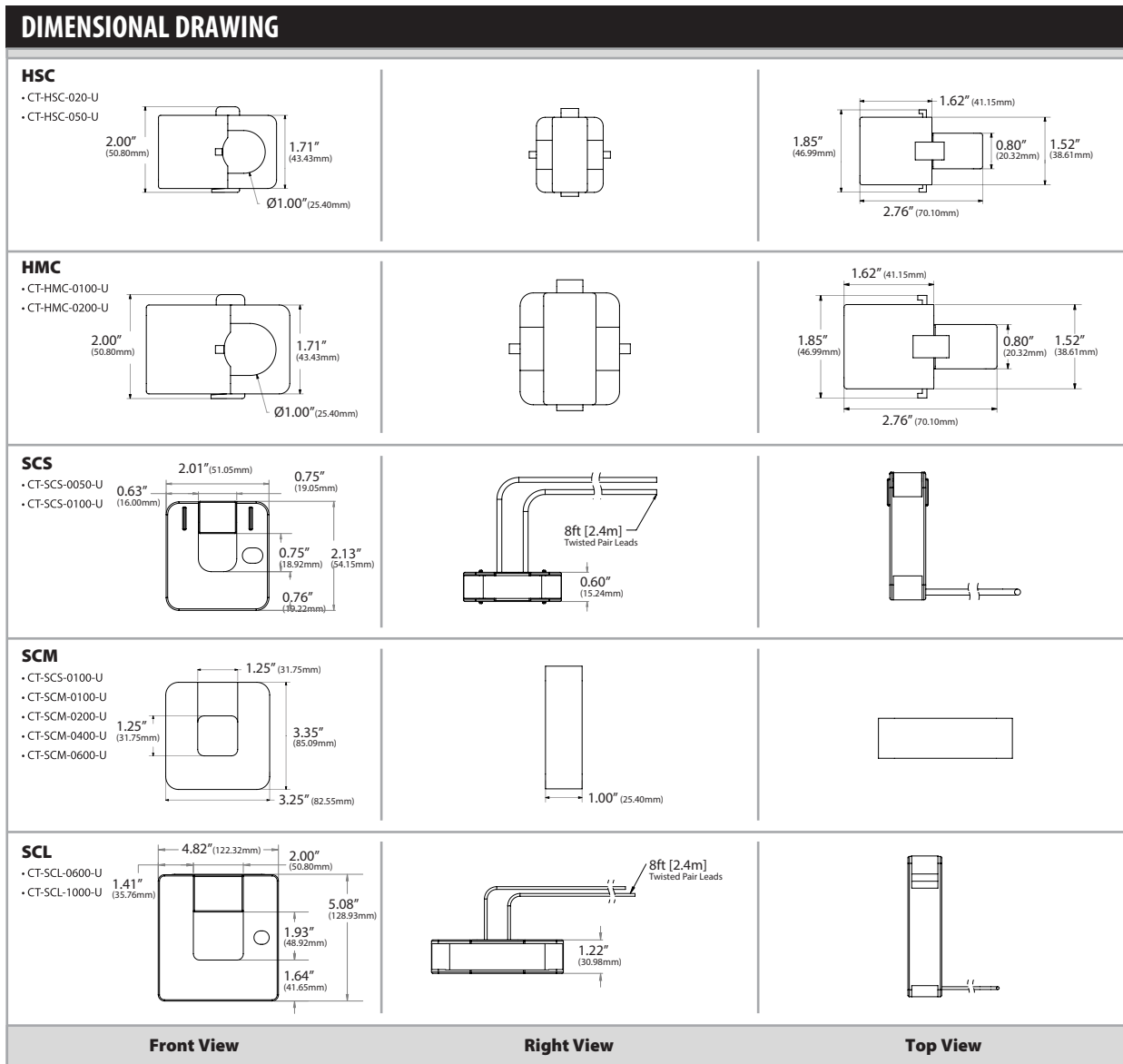

STANDARD ORDERING

Model #	Item #	Rated Current	Operating Current Range	Window Size	Output Signal At Rated Current	Ratio Error (Typical)	Phase Error (Typical)
CT-HSC-020-U	136942	20A	0.25 to 40A	0.4" (10.2mm)	333 mV @ 20A 16.65 mV/AAC	< 0.5% (0.25 - 40A)	< 1.5° from 1 - 40A < 2° from 0.25 - 1A
CT-HSC-050-U	136943	50A	0.25 to 80A	0.4" (10.2mm)	333 mV @ 50A 6.66 mV/AAC	< 0.5% (0.25 - 80A)	< 1.5° from 1 - 40A < 2° from 0.25 - 1A
CT-HMC-0100-U	136944	100A	1 to 200A	1.0" (25.4mm)	333 mV @ 100A 3.33 mV/AAC	< 0.3% (1 - 200A)	< 0.5° from 1 - 200A
CT-HMC-0200-U	136945	200A	1 to 300A	1.0" (25.4mm)	333 mV @ 200A 1.67 mV/AAC	< 1.0% (1 - 300A)	< 0.5° from 1 - 300A
CT-SCS-0050-U	143153	50A	5 to 65A	0.75" (19.05mm)	333 mV @ 50A	< 1.0% @ 50A	< 2° @ 50A
CT-SCS-0100-U	136947	100A	2 to 130A	0.75" (19.05mm)	333 mV @ 100A	< 1.0% @ 100A	< 2° @ 100A
CT-SCM-0100-U	136948	100A	5 to 130A	1.25" (31.75mm)	333 mV @ 100A	< 1.0% @ 100A	< 2° @ 100A
CT-SCM-0200-U	136949	200A	4 to 260A	1.25" (31.75mm)	333 mV @ 200A	< 1.0% @ 200A	< 2° @ 200A
CT-SCM-0400-U	136950	400A	8 to 520A	1.25" (31.75mm)	333 mV @ 400A	< 1.0% @ 400A	< 2° @ 400A
CT-SCM-0600-U	136951	600A	12 to 780A	1.25" (31.75mm)	333 mV @ 600A	< 1.0% @ 600A	< 2° @ 600A
CT-SCL-0600-U¹	136952	600A	30 to 780A	2.0" (50.8mm)	333 mV @ 600A	< 1.0% @ 600A	< 2° @ 600A
CT-SCL-1000-U¹	136953	1000A	20 to 1300A	2.0" (50.8mm)	333 mV @ 1000A	< 1.0% @ 1000A	< 2° @ 1000A

Note: For best accuracy, Rocoil™ flexible CT's (CT-Rxx-A4-U Series) are recommended for use on circuits/services of 600 Amps or greater (See Revenue Grade CT Data Sheet)