



Carbon Monoxide Detector-Transmitter E2608-CO



Features

- Wall-mount or duct-mount version
- Industrial IP65 housing
- Two analog outputs settable to 4-20 mA or 0-10 V
- RS485 Modbus RTU digital interface
- Two relays for alarm / ventilation control
- Attached or remote sensor

Specifications

Calibration	Carbon monoxide CO
Sensor type	Electrochemical
Sampling method	Diffusion
Typical detection range	0...300 ppm 0...1000 ppm
Maximum overload	2000 ppm
Resolution / digital unit	1 ppm
Repeatability	< ± 5 %
Response time T90	< 30 s
Signal update	Every 1 second
Sensor lifetime	> 10 years
Maintenance interval	12 months
Self-diagnostics	Full functionality check at start-up
Warm-up time	≤ 1 min
Power supply	12...36 VDC (default), 24 VAC or 230 VAC as options
Power consumption	< 2 VA
Digital interface	RS485, Modbus RTU protocol
Analog outputs	2 × 4-20 mA / 0-10 V, user settable
Output scale width	Recommended: 5-100% of the range; > 10 × resolution in any case
Output relays	2 × SPST relays (closing contact), 250 VAC / 30 VDC, 5 A max
Default alarm setpoints	RE1 (LOW): set 25; release 20 ppm RE2 (HIGH): set 35; release 28 ppm
Enclosure	Grey ABS plastic, wall mount, protection class IP65
Dimensions	H87 × W82 × D55 mm
Remote sensor probe	Protection IP65, shielded cable default cable length 3.0 m
Operating environment	Industrial indoor and outdoor locations
Operating conditions	-20...+50 °C, 0.9...1,1 atm 15...90% RH non-condensing Explosion-safe areas Non-aggressive atmosphere

NOTE! We offer technical solutions for extreme humidity, please ask for more information

Wall mount version

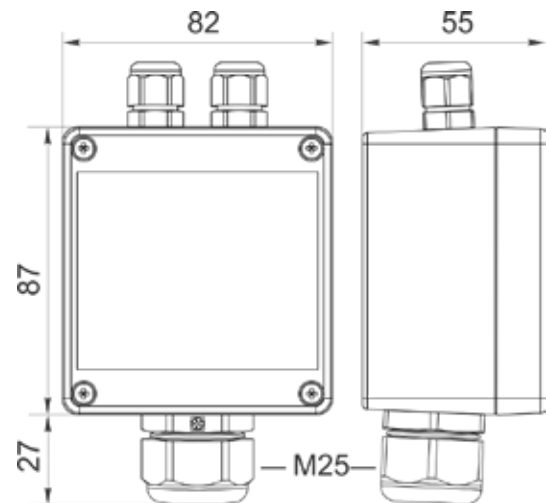

Duct mount version

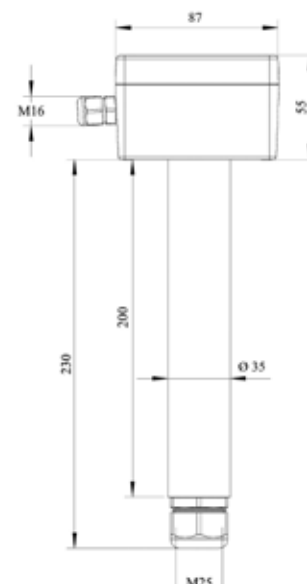

Connection diagrams

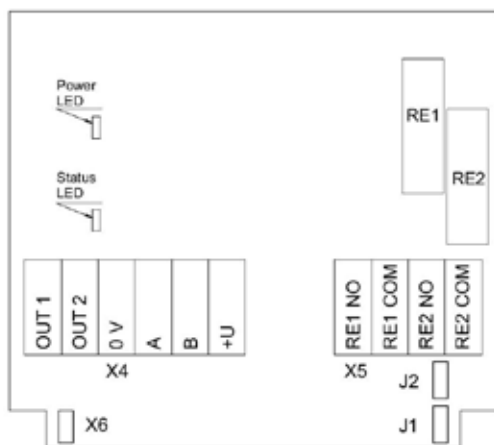

Version without PSU

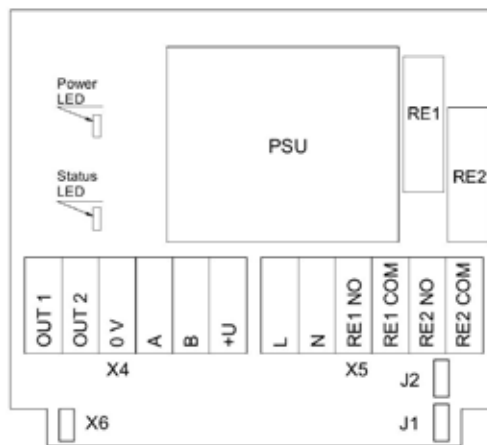

Version with PSU

Jumpers

J1 OUT1 type (open: 4-20 mA; closed 0-10 V)
 J2 OUT2 type (open: 4-20 mA; closed 0-10 V)
 X6 Reset Modbus network parameters to default

X4 terminals

OUT1 4-20 mA / 0-10 V output
 OUT2 4-20 mA / 0-10 V output
 0V 0 V / 24 VAC Neutral (optional)
 A RS485 A / Data +
 B RS485 B / Data -
 +U +24 VDC / 24 VAC Phase (optional)

X5 terminals (optional)

L 90...265 VAC Phase
 N 90...265 VAC Neutral
 RE1 NO Relay 1, normally open terminal
 RE1 COM Relay 1, common terminal
 RE2 NO Relay 2, normally open terminal
 RE2 COM Relay 2, common terminal

Remote probe

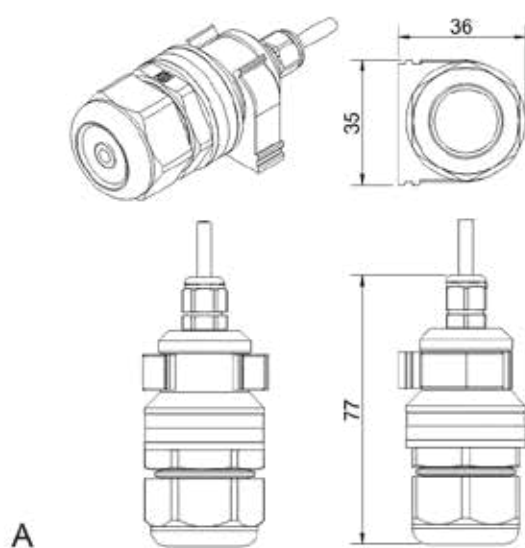

A

Wall mount remote probe with fixing clamp (default version)

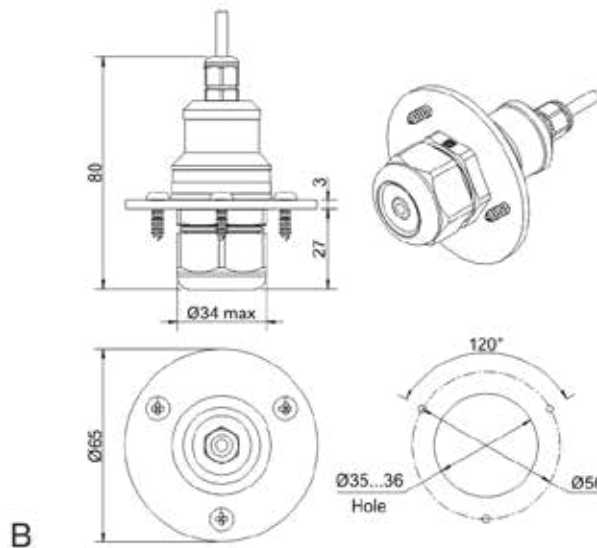

B

Remote probe with rubber flange and three self-tapping screws (on request)