



Ammonia Detector-Transmitter E2608-NH3-P



Features

- Wall-mount or duct-mount version
- Industrial IP65 housing
- Two analog outputs settable to 4-20 mA or 0-10 V
- RS485 Modbus RTU digital interface
- Two relays for alarm / ventilation control
- Attached or remote sensor

Specifications

Calibration	Ammonia NH ₃
Sensor type	Pellistor (catalytic bead)
Sampling method	Diffusion
Typical detection range	0...15%vol. (0...100%LEL NH ₃)
Resolution	0.1%vol. or 1%LEL
Response time T90	≤10 s
Sensor lifetime	> 3 years
Calibration interval	6 months
Signal update	Every 1 second
Self-diagnostics	Full functionality check at start-up
Warm-up time	≤ 1 min
Power supply	12...36 VDC (default), 24 VAC or 230 VAC as options
Power consumption	< 2 VA
Digital interface	RS485, Modbus RTU protocol
Analog outputs	2 × 4-20 mA / 0-10 V, user settable
Output scale width	Recommended: 20-100% of the range; > 10 × resolution in any case Analog output scale can be set according to customer's requirement (e.g. 0...4%vol. NH ₃)
Output relays	2 × SPST relays (closing contact), 250 VAC / 30 VDC, 5 A max
Enclosure	Grey ABS plastic, wall mount, protection class IP65
Dimensions	H87 × W82 × D55 mm
Remote sensor probe	Protection IP65, shielded cable default cable length 3.0 m
Operating environment	Industrial indoor and outdoor locations
Operating conditions	-20...+60 °C 95% RH non-condensing; 0.9...1,1 atm Explosion-safe areas Normal ambient oxygen level No strong mechanical shock, vibrations or EMI; Avoid exposure to corrosive gases or silicone containing products.

Wall mount version

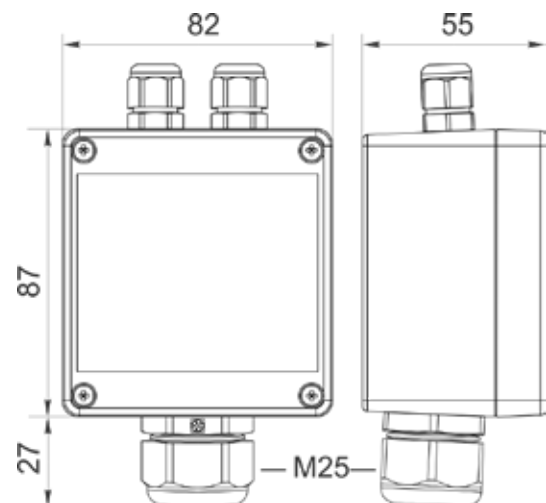

Duct mount version

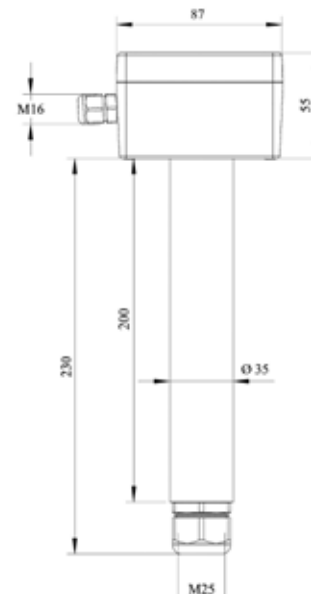

Connection diagrams

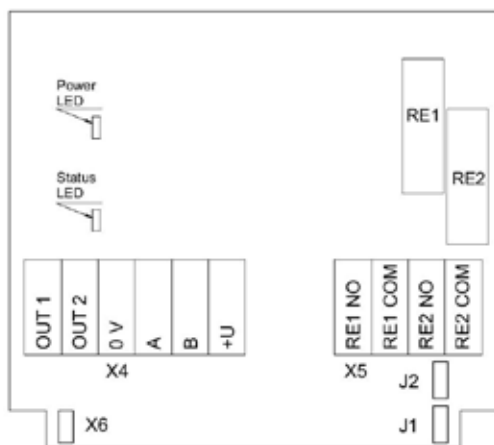

Version without PSU

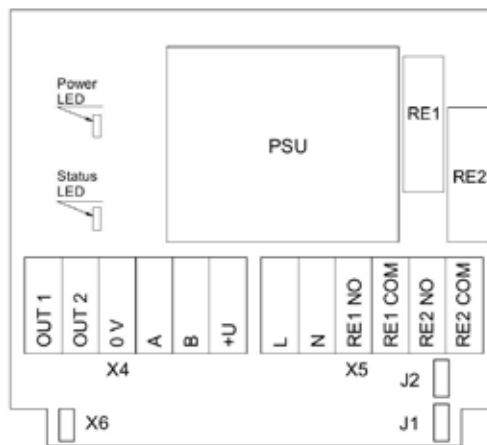

Version with PSU

Jumpers

J1

OUT1 type (open: 4-20 mA; closed 0-10 V)

J2

OUT2 type (open: 4-20 mA; closed 0-10 V)

X6

Reset Modbus network parameters to default

X4 terminals

OUT1

4-20 mA / 0-10 V output

OUT2

4-20 mA / 0-10 V output

0V

0 V / 24 VAC Neutral (optional)

A

RS485 A / Data +

B

RS485 B / Data -

+U

+24 VDC / 24 VAC Phase (optional)

X5 terminals (optional)

L

90...265 VAC Phase

N

90...265 VAC Neutral

RE1 NO

Relay 1, normally open terminal

RE1 COM

Relay 1, common terminal

RE2 NO

Relay 2, normally open terminal

RE2 COM

Relay 2, common terminal

Remote probe

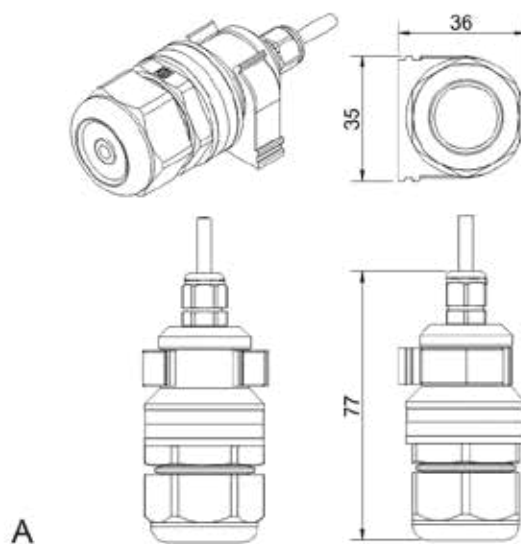

A

Wall mount remote probe with fixing clamp (default version)

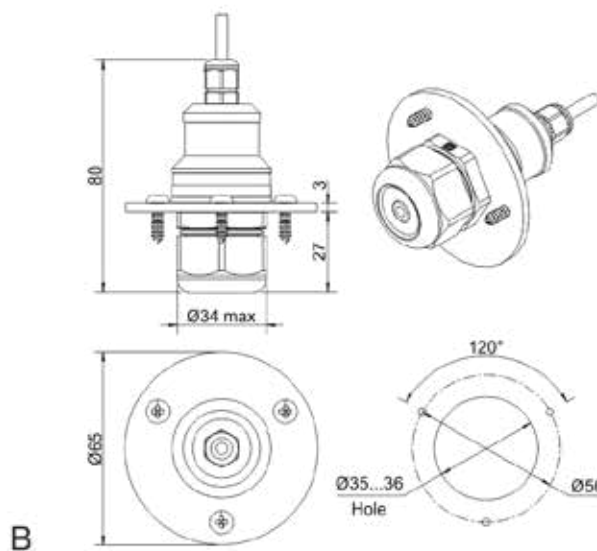

B

Remote probe with rubber flange and three self-tapping screws (on request)