



# Carbon Monoxide Transmitter E2615-CO



## Features

- Maintenance free sensor
- User selectable output 4-20 mA / 0-10 V
- Range of compact wall mount enclosures
- Low cost for volume HVAC applications

## Specifications

Sensor type	Electrochemical
Sampling method	Diffusion
Detection range	0-300 ppm
Maximum overload	2000 ppm
Response time T90	< 30 s
Sensor protection	Microporous PTFE dust filter
Warm-up time	≤ 1 min
Analog output	4-20 mA / 0-10 V, user settable
Power supply	24 VDC ± 20%
Power consumption	< 1 W
Sensor lifetime	≥ 7 years
Sensitivity drift	< ± 20% in 5 years
Indoors enclosure IP20 version	White, ivory or black ABS plastic, wall mount, protection class IP20
Weatherproof enclosure IP65 version	Grey ABS plastic, wall mount, protection class IP65
Operating conditions	-20...+50°C, 15-90%RH, pressure 0,9...1,1 atm
EMC Emissions	To EN 61000-6-3, EN 61326-1
EMC Immunity	To EN 61000-6-1, EN 61000-6-2

## IP65 Enclosures

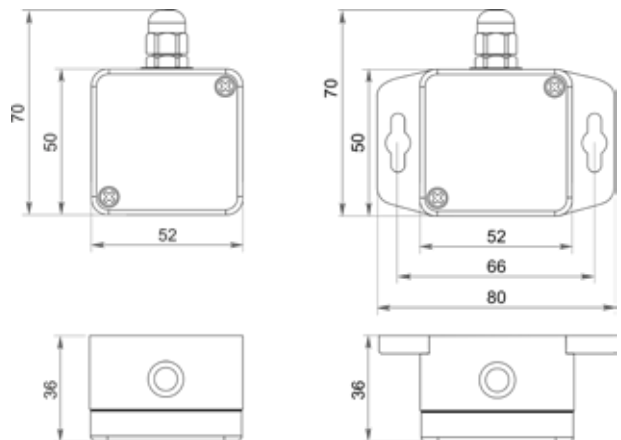

## IP20 Enclosures

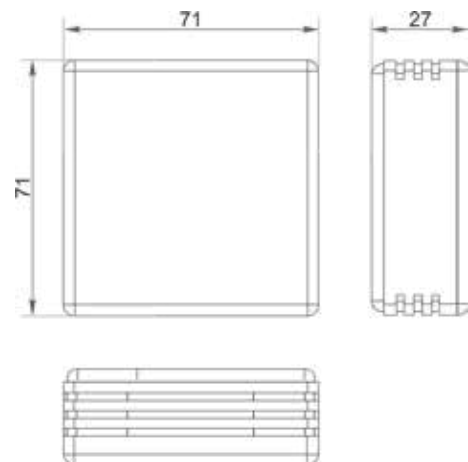

## Connection diagrams

### 3-wire 4-20 mA output



### 3-wire 0-10 V output

