



Combustible Gases Detector-Transmitter E2608-LEL



Features

- Wall-mount or duct-mount version
- Industrial IP65 housing
- Two analog outputs settable to 4-20 mA or 0-10 V
- RS485 Modbus RTU digital interface
- Two relays for alarm / ventilation control
- Attached or remote sensor

Specifications

Detected gases	Hydrogen, methane, acetylene, propane, butane, hexane, octane	
Default calibration	Methane CH ₄	
Sensor type	Metal-oxide semiconductor Pellistor (catalytic bead) on demand	
Sampling method	Diffusion	
Sensor	MOS	Pellistor
Typical detection range	0...100% LEL	0...100% LEL
Resolution	0.1% LEL	1% LEL
Response time T90	ca. 60 s	≤10 s
Sensor lifetime	> 5 years	> 5 years
Calibration interval	12 months	6 months
Signal update	Every 1 second	
Self-diagnostics	Full functionality check at start-up	
Warm-up time	≤ 1 min	
Power supply	12...36 VDC (default), 24 VAC or 230 VAC as options	
Power consumption	< 2 VA	
Digital interface	RS485, Modbus RTU protocol	
Analog outputs	2 × 4-20 mA / 0-10 V, user settable	
Output scale width	Recommended: 20-100% of the range; > 10 × resolution in any case	
Output relays	2 × SPST relays (closing contact), 250 VAC / 30 VDC, 5 A max	
Default alarm setpoints	LOW: set 20 %LEL, release 16% LEL; HIGH:set 50%LEL, release 40% LEL	
Enclosure	Grey ABS plastic, wall mount, protection class IP65	
Dimensions	H87 × W82 × D55 mm	
Remote sensor probe	Protection IP65, shielded cable default cable length 3.0 m	
Operating environment	Industrial indoor and outdoor locations	
Operating conditions	-40...+70 °C -40...+70°C 95% RH non-condensing; 0.9...1,1 atm Explosion-safe areas Normal ambient oxygen level No strong mechanical shock, vibrations or EMI; Avoid exposure to corrosive gases or silicone containing products.	

Wall mount version

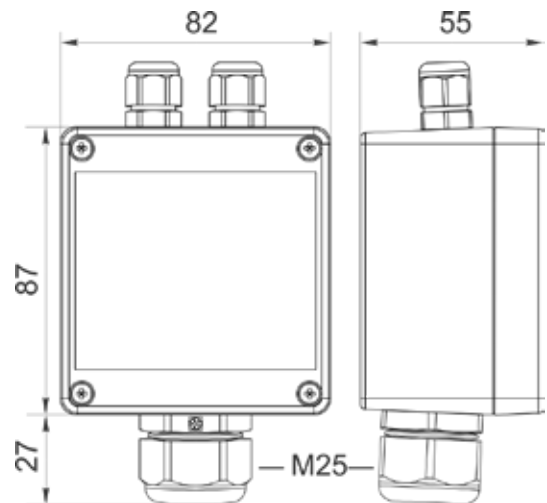

Duct mount version

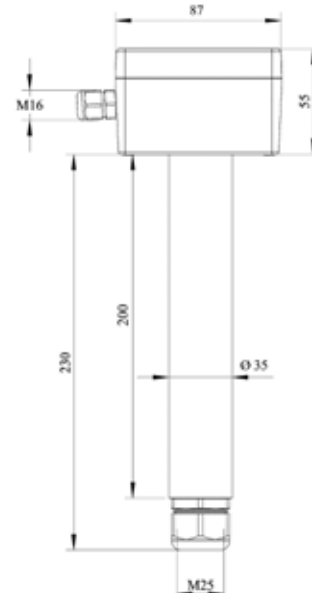

Ask for other versions or custom designed products



Connection diagrams

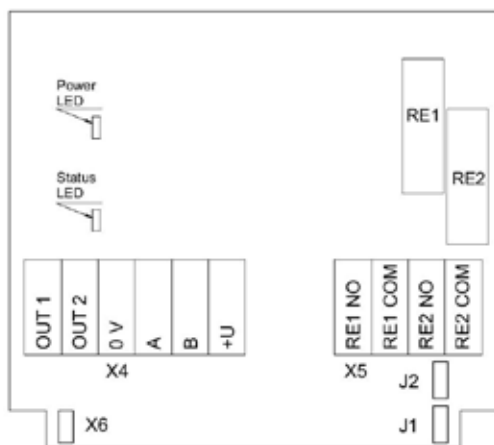

Version without PSU

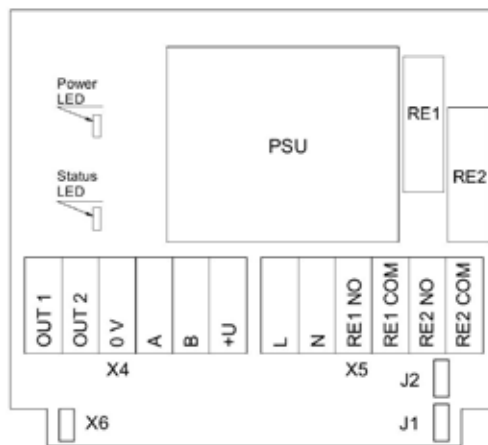

Version with PSU

Jumpers

- J1 OUT1 type (open: 4-20 mA; closed 0-10 V)
- J2 OUT2 type (open: 4-20 mA; closed 0-10 V)
- X6 Reset Modbus network parameters to default

X4 terminals

- OUT1 4-20 mA / 0-10 V output
- OUT2 4-20 mA / 0-10 V output
- 0V 0 V / 24 VAC Neutral (optional)
- A RS485 A / Data +
- B RS485 B / Data -
- +U +24 VDC / 24 VAC Phase (optional)

X5 terminals (optional)

- L 90...265 VAC Phase
- N 90...265 VAC Neutral
- RE1 NO Relay 1, normally open terminal
- RE1 COM Relay 1, common terminal
- RE2 NO Relay 2, normally open terminal
- RE2 COM Relay 2, common terminal

Remote probe

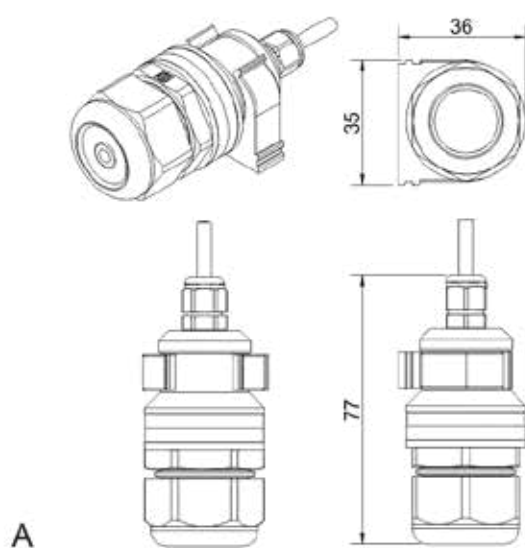

A

Wall mount remote probe with fixing clamp (default version)

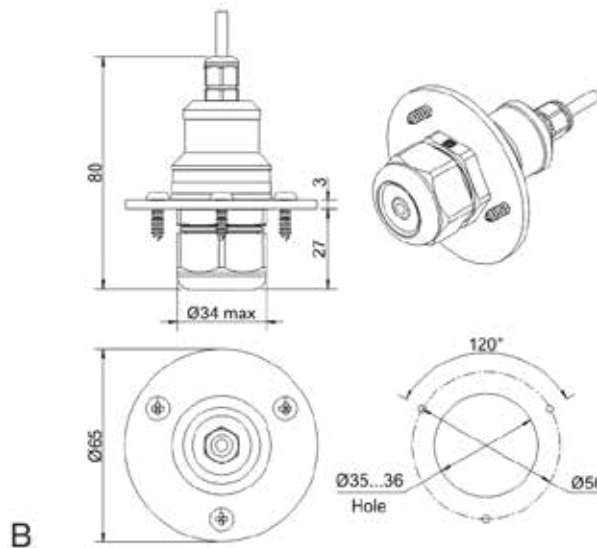

B

Remote probe with rubber flange and three self-tapping screws (on request)

