

Overview



The 2-path flowmeter SITRANS FUE380 comes as battery or mains-powered and is designed to measure water flow in district heating plants, local networks, boiler stations, substations, chiller plants (including glycol mixes without type approval) and other general water applications.

The flowmeter FUE380 is approved according to energy meter standards EN 1434 class 2, OIML R 75 class 2 and MID class 2. Metrological parameters are protected against manipulation. The type-approved flowmeter version is named SITRANS FUE380. For a standard flowmeter type FUS380 without a type approval, see the section about FUS380.

Technically, the meter types SITRANS FUS380 and SITRANS FUE380 are completely identical, only difference is the calibration limit and the type approval for custody transfer.

Benefits

- Battery-powered up to 6 years
- 115/230 V mains-powered with back-up battery option in case of mains power failure
- Fast measuring frequency 15 Hz/0.5 Hz (230 V AC/Battery)
- Easy one-button straight forward display
- 2-path measuring principle for optimum accuracy
- Compact or remote mounting
- Measures on most district water qualities and water conductivities
- No pressure drop
- Long-term stability
- 2 galvanically isolated digital outputs for easy connection to a calculator (potential-free)
- Analog output 4 to 20 mA
- Bidirectional measurement, with 2 totalizers and outputs
- Dynamic range $Q_i:Q_p$ up to 1:50/100 or max. range $Q_i:Q_s$ up to 1:400

Application

The main application for SITRANS FUE380 is measurement of water flow or water flow in energy meter systems for custody transfer in district heating networks or chilled water (including glycol mixes without type approval).

Combined with an energy calculator and a pair of temperature sensors, SITRANS FUE380 can be used as part of an energy meter system. For this purpose Siemens offers energy calculator SITRANS FUE950.

Design

The 2-path design of SITRANS FUE380 ensures maximum accuracy under short inlet conditions. The approved flowmeter consists of a flow sensor pipe, 4 transducers/transducer cables and a transmitter SITRANS FUE080.

The unit is available in a compact or a remote version. Both versions are pre-mounted with short coax-cables. Remote transmitter up to a distance of 30 m by one Sensor link cable (SSL).

Compact mounting is only possible up to 120 °C (248 °F). The sensor must be isolated to protect transmitter from heat. The transmitter is available in an IP67/NEMA 4X/6 enclosure.

FUE380 MI-004 approval

The SITRANS FUE380 program is type-approved according to international energy meter standard EN 1434. On 1 November 2006 the MI-004 energy meter directive became effective providing that all energy meters with a MI-004 verification label can be sold across the EU borders.

The FUE380 are MI-004 verified and labeled products according to Directive 2014/32/EU of the European Parliament and Council of 26 February, 2014 on measuring instruments, Annex IV Thermal Energy Meters (MI-004), in sizes from DN 50 to DN 1200.

The MID certification is obtained as module B + module D approvals according to the above-mentioned directive.

Module B: MI-004 Type approval according to EN 1434: 2007 (approved for media water)

Module D: Quality insurance MID approval of production

The MID system label with the approval information is placed on the side of the transmitter and on the sensor. An example of the product label is shown below:



FUE380 transmitter label (with MID first verification)

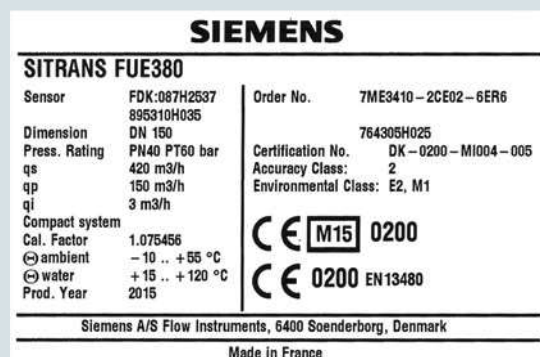

FUE380 sensor label (with MID first verification)

Flow Measurement

SITRANS FS (ultrasonic)

Inline ultrasonic flowmeters

SITRANS FUE380 flowmeter with CT approval

Function

Together with the SIMATIC PDM tool the FUE380 offers the possibility of testing and verifying the flowmeter on site and creating a printed "Qualification Certificate" with specific data that defines the quality status of the measurement.

The Qualification Certificate shows information about the actual status of the flowmeter:

- General settings, flowmeter and battery information, totalizer values, and pulse output settings
- Detailed information about the transmitter and the sensor functionality, and a main parameter list for evaluating the functionality of the flowmeter

Integration

The flowmeter digital output is often used as input for an energy meter or as input for digital systems for remote reading.

SITRANS FUE380 has two digital output functions that can be individually selected.

Pulse output rate is defined when ordering. To get optimal benefit the pulse value must be selected as low as possible.

If the flowmeter forms part of an energy meter system for custody transfer, no further approvals are needed, except possible local approvals on the flowmeter.

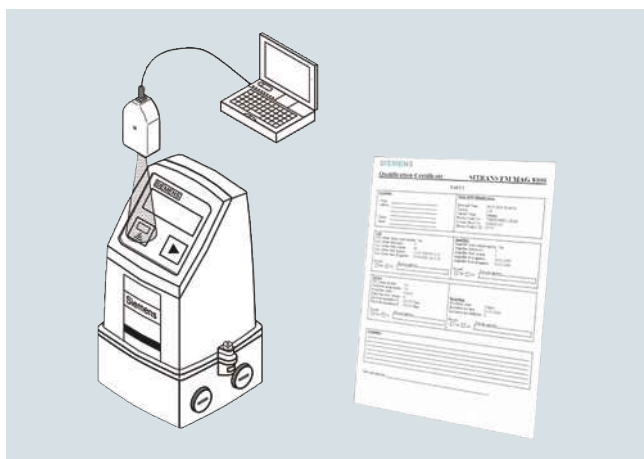

Configuration

Selection guide SITRANS FUE380, type-approved flowmeter

DN	Q_s (m ³ /h)	Q_{max} (m ³ /h) (105% of Q_s)	Q_p (m ³ /h)	Q_i (m ³ /h) (1:50 of Q_p)	Q_i (m ³ /h) (1:100 of Q_p) EN 1434/MID	Cut-off (m ³ /h) (95% of Q_i)	Cut-off (% of Q_{max})	Typical pulse value (l/pulse)
		105%		50	100	95%		
50	30	31.5	15	0.3	-	0.285	0.95	1
50	45	47.25	15	0.3	-	0.285	0.63	1
50	45	47.25	30	-	0.3	0.285	0.63	1
65	50	52.5	25	0.5	-	0.475	0.95	1
65	72	75.6	25	0.5	-	0.475	0.66	1
65	72	75.6	50	-	0.5	0.475	0.66	1
80	80	84	40	0.8	-	0.760	0.95	2.5
80	120	126	40	0.8	-	0.760	0.63	2.5
80	120	126	80	-	0.8	0.760	0.63	2.5
100	120	126	60	1.2	-	1.140	0.95	2.5
100	180	189	60	1.2	-	1.140	0.63	2.5
100	180	189	120	-	1.2	1.140	0.63	2.5
125	200	210	100	2.0	-	1.900	0.95	2.5
125	280	294	100	2.0	-	1.900	0.68	2.5
125	280	294	200	-	2.0	1.900	0.68	2.5
150	300	315	150	3.0	-	2.850	0.95	10
150	420	441	150	3.0	-	2.850	0.68	10
150	420	441	300	-	3.0	2.850	0.68	10
200	500	525	250	5.0	-	4.750	0.95	10
200	700	735	250	5.0	-	4.750	0.68	10
200	700	735	500	-	5.0	4.750	0.68	10
250	800	840	400	8.0	-	7.600	0.95	10
250	1120	1176	400	8.0	-	7.600	0.68	10
250	1120	1176	800	-	8.0	7.600	0.68	10
300	1120	1176	560	11.2	-	10.640	0.95	50

Configuration (continued)

DN	Q _s (m ³ /h)	Q _{max} (m ³ /h) (105% of Q _s)	Q _p (m ³ /h)	Q _i (m ³ /h) (1:50 of Q _p)	Q _i (m ³ /h) (1:100 of Q _p) EN 1434/MID	Cut-off (m ³ /h) (95% of Q _i)	Cut-off (% of Q _{max})	Typical pulse value (l/pulse)
300	1560	1638	560	11.2	-	10.640	0.68	50
300	1560	1638	1120	-	11.2	10.640	0.68	50
350	1500	1575	750	15.0	-	14.250	0.95	50
350	2100	2205	750	15.0	-	14.250	0.68	50
350	2100	2205	1500	-	15.0	14.250	0.68	50
400	1900	1995	950	19.0	-	18.050	0.95	50
400	2660	2793	950	19.0	-	18.050	0.68	50
400	2660	2793	1900	-	19.0	18.050	0.68	50
500	2950	3097.5	1475	29.5	-	28.025	0.95	100
500	4130	4336.5	1475	29.5	-	28.025	0.68	100
500	4130	4336.5	2950	-	29.5	28.025	0.68	100
600	4300	4515	2150	43.0	-	40.850	0.95	100
600	6020	6321	2150	43.0	-	40.850	0.68	100
600	6020	6321	4300	-	43.0	40.850	0.68	100
700	5800	6090	2900	58.0	-	55.100	0.95	100
700	8120	8526	2900	58.0	-	55.100	0.68	100
700	8120	8526	5800	-	58.0	55.100	0.68	100
800	7600	7980	3800	76.0	-	72.200	0.95	100
800	10 640	11 172	3800	76.0	-	72.200	0.68	100
800	10 640	11 172	7600	-	76.0	72.200	0.68	100
900	10 000	10 500	5000	100.0	-	95.000	0.95	100
900	14 000	14 700	5000	100.0	-	95.000	0.68	100
900	14 000	14 700	10 000	-	100.0	95.000	0.68	100
1000	14 000	14 700	10 000	-	100.0	95.000	0.68	100
1200	14 000	14 700	10 000	-	200.0	190.000	1.36	100

Dynamic range Q_i:Q_p: better than 1:100 to OIML R 75 class 2 and MID EN 1434 class 2.

Q_i (Q_{min}) means the minimal and Q_p (Q_{nom}) the nominal flow rate according to the approval requirements.

Q_s is the highest operatable flow rate. The maximum flow rate (Q_{max}) is 105 % of Q_s. The low flow cut off is 95 % of Q_i.

Q_i, Q_p and Q_s are shown on the system nameplate of the FUE380.

In order to obtain best pulse output resolution in the range Q_{min} to Q_s of approx. 100 Hz at Q_s, two or three flow values for every dimension can be selected at ordering. Therefore the ordering data table also shows Q_p (Q_n). This flow rate is between Q_i (Q_{min}) and Q_s and indicates the normal or typical flow according to the approval requirements.

Note:

The minimum flow (Q_i) should be checked in the PIA-selector or product master data base (PMD).

To get optimal benefit of the pulses the pulse value and pulse length shall be selected as low as possible. The following calculation formula can be used for determining the shortest pulse value at a pulse length of 5 ms: L/pulse > Q_s (m³/h) /360.

For example Q_s = 300 m³/h; L/pulse > 300/360; L/pulse > 0.83; therefore the pulse value must be 1 l/pulse

Flow Measurement

SITRANS FS (ultrasonic)

Inline ultrasonic flowmeters

SITRANS FUE380 flowmeter with CT approval

Technical specifications

Pipe design	2-path sensor with flanges and inline transducers wet-calibrated from factory
Nominal size welded version (DN 50 ... DN 80 in bronze)	DN 50, 65, 80, 100, 125, 150, 200, 250, 300, 350, 400, 500, 600, 700, 800, 900, 1000, 1200
Pressure rate	PN 16, PN 25, PN 40 EN 1092-1 EN 1092-1 flanges: • type 01 (B): DN 100 to DN 125 • type 11 (B): DN 150 to DN 200 • type 11 (B) 'design': DN 50 to DN 80
Pipe material	• DN 100 ... DN 1200: Carbon Steel EN 1.0345/P235 GH, painted in light-gray. • DN 50 ... DN 80: Die-cast bronze G-CuSn10/W2.1050.01 (EN1982)
Transducer design	• DN 100 ... DN 1200: Inline version and welded onto the pipe • DN 50 ... DN 80: Screwed into the pipe
Transducer material	Stainless steel (AISI 316/1.4404)/brass (CuZn ₃₆ Pb ₂ As)

Sensor operating conditions

Ambient temperature	-10 ... +60 °C (14 ... 140 °F) (MID version: -10 ... +55 °C (14 ... 131 °F)) -40 ... +85 °C (-40 ... +185 °F)
• Operation	
• Storage	
Measured media	Heating water, according to VDI-2035 (pH 8.2 - 10.5), industrial VdTUV information sheet 1466 and AGFW information sheet FW 510.
Media/surface temperature	
• DN 100 ... DN 1200	Remote: 2 ... 200 °C (35.6 ... 392 °F) MID: min. +15 °C/+59 °F
• DN 50 ... DN 80	Remote: 2 ... 150 °C (35.6 ... 302 °F) MID: min. +15 °C/+59 °F
• DN 50 ... DN 1200	Compact: 2 ... 120 °C (35.6 ... 248 °F) MID: min. +15 °C/+59 °F
Degree of protection	Sensor connection IP67/NEMA 4X/6
Electromagnetic compatibility	
• Emitted interference	To EN 55011/CISPR-11
• Noise immunity	To EN/IEC 61326-1 (Industry)
• MID	Environment class E2 and M1
Max. flow velocity at Q _s	DN 50 ... DN 1200: 9 m/s (29.5 ft/s)

Transmitter

The transmitter related to this system is the SITRANS FUS080.

Technical specifications to the FUS080 see page 3/259.

Sensor cable

Transducer cable length	Pre-mounted with short coax-cables
Sensor Ink cable length (SSL)	5, 10, 20, 30 m (16.4, 32.8, 65.6, 98.4 ft)

Certificates and approvals

Conformity certificate (CE)	The devices are supplied as standard with a Siemens Certificate of Conformity on DVD.
Material certificate	Material certificate according EN 10204-3.1 is optionally available.
Calibration report	A standard calibration report is shipped with every flowmeter. Extended accredited ISO/IEC 17025 calibration certificates optionally available
Approvals	<ul style="list-style-type: none"> • Approval standards: N 1434 and OIML R 75 Class 2 • Type approval: ID, MI-004, class 2 approval and certification (according to EN 434) • CPA/CMC (China)

The sensors are approved according to EU directive 2014/68/EU regarding fluid group 1, classified in category III. Design according to EN 13480 (PED Directive).

Type-dependent settings

Flow value	Predefined according to EN 1434/OIML R 75/MID
Approval	Country specific
Flow rate v _f	0.02 ... 9 m/s (0.065 ... 29.5 ft/s)
Output A	Preset: Forward pulses
Output B	Preset: Alarm
Pulse value A & B (depending on DN value)	Preset: See scheme – previous page Preset for SITRANS FUE950 or free selectable, depending on flow rate (Q _s)
Pulse width	Preset: 5 ms
Flow unit setup	Preset: m ³ /h
Volume unit setup	Preset: m ³

Flowmeter Calibration and traceability

To ensure continuous accurate measurement, flowmeters must be calibrated. The calibration is conducted at Siemens flow facilities with traceable instruments referring directly to the physical unit of measurement according to the International System of Units (SI).

Therefore, the calibration certificate ensures recognition of the test results worldwide, including the US (NIST traceability). Siemens offers accredited calibrations assured to ISO 7025 in the flow range from 0.0001 m³/h to 10 000 m³/h. Siemens Flow Instruments accredited laboratories are recognized by ILAC MRA (International Laboratory Accreditation Corporation - Mutual Recognition Arrangement) ensuring international traceability and recognition of the test results worldwide.

A standard calibration certificate with Q_n as selected flow is shipped with each SITRANS FUE380. This production calibration protocol consists of 2 x 3 points at Q_i, 10% Q_p and Q_p (max. 4 200 m³/h).

Typical accuracy SITRANS FUE380:

$$\pm (0.5 + 0.02 Q_p/Q) [\%]$$

Q_p according to EN 1434/OIML requirements.

Example: DN 100, Q_p = 60 m³/h at Q = 1.2 m³/h:

Accuracy at 1.2 m³/h = typical 1.5 %

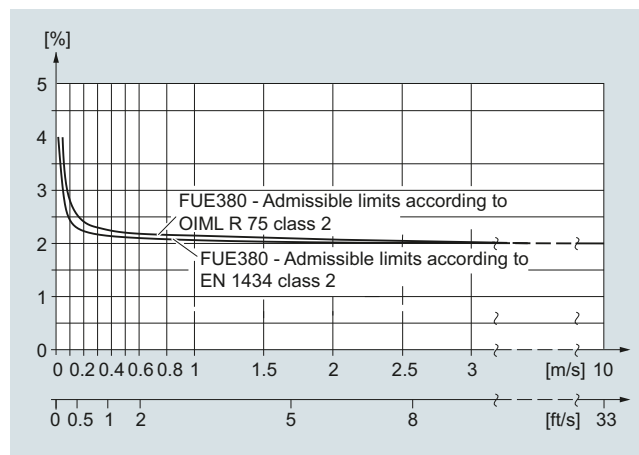

SITRANS FUE380 fulfils the requirements $E_f = \pm (2 + 0.02 Q_p/Q_i)$ max. $\pm 5 \%$, according to EN 1434 and OIML R 75, class 2 or MID requirements.

Selection and ordering data

Article No.

Flowmeter SITRANS FUS380 (type-approved)

7ME3410-

Ord.
Code

Click on the Article No. for the online configuration in the PIA Life Cycle Portal.

Diameter	Approval	Pressure rating	Flow setting [m ³ /h]		Article No.
			Q _p (Q _n)	Q _s	
Pipe material: Die-cast bronze					
DN 50 (2")		PN 40	15	30	1 B
DN 50 (2")		PN 40	15	45	1 C
DN 50 (2")	EN 1434	PN 40	30	45	1 D
DN 65 (2½")		PN 40	25	50	1 F
DN 65 (2½")		PN 40	25	72	1 G
DN 65 (2½")	EN 1434	PN 40	50	72	1 H
DN 80 (3")		PN 40	40	80	1 K
DN 80 (3")		PN 40	40	120	1 L
DN 80 (3")	EN 1434	PN 40	80	120	1 M
Pipe material: Carbon steel					
DN 100 (4")		PN 16, PN 40	60	120	1 P
DN 100 (4")		PN 16, PN 40	60	180	1 Q
DN 100 (4")	EN 1434	PN 16, PN 40	120	180	1 R
DN 125 (5")		PN 16, PN 40	100	200	1 T
DN 125 (5")		PN 16, PN 40	100	280	1 U
DN 125 (5")	EN 1434	PN 16, PN 40	200	280	1 V
DN 150 (6")		PN 16, PN 40	150	300	2 B
DN 150 (6")		PN 16, PN 40	150	420	2 C
DN 150 (6")	EN 1434	PN 16, PN 40	300	420	2 D
DN 200 (8")		PN 16, PN 25, PN 40	250	500	2 F
DN 200 (8")		PN 16, PN 25, PN 40	250	700	2 G
DN 200 (8")	EN 1434	PN 16, PN 25, PN 40	500	700	2 H
DN 250 (10")		PN 16, PN 25, PN 40	400	800	2 K
DN 250 (10")		PN 16, PN 25, PN 40	400	1120	2 L
DN 250 (10")	EN 1434	PN 16, PN 25, PN 40	800	1120	2 M
DN 300 (12")		PN 16, PN 25	560	1120	2 P
DN 300 (12")		PN 16, PN 25	560	1560	2 Q
DN 300 (12")	EN 1434	PN 16, PN 25	1120	1560	2 R
DN 350 (14")		PN 16, PN 25	750	1500	2 T
DN 350 (14")		PN 16, PN 25	750	2100	2 U
DN 350 (14")	EN 1434	PN 16, PN 25	1500	2100	2 V
DN 400 (16")		PN 16, PN 25	950	1900	3 B
DN 400 (16")		PN 16, PN 25	950	2660	3 C
DN 400 (16")	EN 1434	PN 16, PN 25	1900	2660	3 D
DN 500 (20")		PN 16, PN 25	1475	2950	3 K
DN 500 (20")		PN 16, PN 25	1475	4130	3 L
DN 500 (20")	EN 1434	PN 16, PN 25	2950	4130	3 M
DN 600 (24")		PN 16, PN 25	2150	4300	3 T
DN 600 (24")		PN 16, PN 25	2150	6020	3 U
DN 600 (24")	EN 1434	PN 16, PN 25	4300	6020	3 V
DN 700 (28")		PN 16, PN 25	2900	5800	4 F
DN 700 (28")		PN 16, PN 25	2900	8120	4 G
DN 700 (28")	EN 1434	PN 16, PN 25	5800	8120	4 H
DN 800 (32")		PN 16, PN 25	3800	7600	4 P
DN 800 (32")		PN 16, PN 25	3800	10640	4 Q
DN 800 (32")	EN 1434	PN 16, PN 25	7600	10640	4 R

Selection and ordering data

Article No.

Flowmeter SITRANS FUS380 (type-approved)

7ME3410-

Ord.
Code

Flowmeter SITRANS FUE080 power/analog output

115 ... 230 V AC

3.6 V Lithium battery, dual pack is included

115 ... 230 V AC, backup 3.6 V DC Lithium battery, single pack is included

3.6 V battery version (no battery pack included)

Option with 4 ... 20 mA analog output module

- 115 ... 230 V AC
- 115 ... 230 V AC, backup 3.6 V DC, Lithium battery, single pack is included

Note:

Lithium batteries are subject to special transportation regulations according to United Nations "Regulation of Dangerous Goods, UN 3090 and UN 3091". Special transport documentation is required to observe these regulations. This may influence both transport time and costs.

Country specific design

Neutral, no approval mark

China, PA 2008-T222 C

Russia, EN 1434/OIML R75 M

MID-Approval (MI004), Language on name plate English

MID-Approval (MI004), Language on name plate German

MID-Approval (MI004), Language on name plate Polish

MID-Approval (MI004), Language on name plate French

Pulse width setup

Pulse width

- 5 ms (standard)
- 10 ms
- 20 ms
- 50 ms
- 100 ms
- 200 ms
- 500 ms

Additional information

Please add "-Z" to Article No. and specify Order code(s) and plain text.

Order code

Calibration/certificate FUS380

Production calibration for DN 50 ... 1200 with Q_n as selected in diameter. Incl. Calibration protocol: 2 x 3 points, Q_i , 10 % Q_p and Q_p (max. 8000 m³/h).

Included

Accredited Siemens ISO/IEC 17025 calibration for DN 50 ... 200 with Q_n as selected in diameter. Certificate: 2 x 5 points, Q_i , 5 %, 10 %, 50 % and 100 % of Q_p (max. 630 m³/h).

D20

Accredited Siemens ISO/IEC 17025 calibration for DN 250 ... 600 with Q_n as selected in diameter. Certificate: 2 x 5 points, 5 %, 10 %, 50 % and 100 % of Q_p (max. 2800 m³/h).

D21

Accredited Siemens ISO/IEC 17025 calibration, DN 500 ... 1200 with Q_n as selected in diameter. Certificate: 2 x 5 points, Q_i , 5 %, 10 %, 50 % and 100 % of Q_p (max. 8000 m³/h).

D22

Output B as reverse flow pulses. No calibration/verification of this function.

E21

Material certificate

EN 10204-3.1 (pipe material)

C12

Tag name plate

Stainless steel TAG plate (1 x 24 x 80 mm), wire fixed. Font size depends on text length: 8 mm for 1 ... 10 characters, 4 mm for 11 ... 20 characters (specify in plain text).

Y17

Please use online Product selector to get latest updates:

<http://www.pia-selector.automation.siemens.com>

Article No.	Ord. Code
7ME3410-	
0	
B	
D	
E	
G	
R	
U	
	A
	C
	M
	R
	S
	T
	U
	2
	3
	4
	5
	6
	7
	8

Flowmeter SITRANS FUE380 operating instructions, accessories and spare parts

Operating instructions

Description

Article No.

- English
- German

A5E00730100

A5E00740611

All literature is available to download for free, in a range of languages, at <http://www.siemens.com/processinstrumentation/documentation>

For accessories and spare parts see the section about FUS080/FUE080.

Flow Measurement

SITRANS FS (ultrasonic)

Inline ultrasonic flowmeters

SITRANS FUS380/FUE380 dimensional drawings and circuit diagrams

Dimensional drawings

Flowmeter SITRANS FUS380 and FUE380

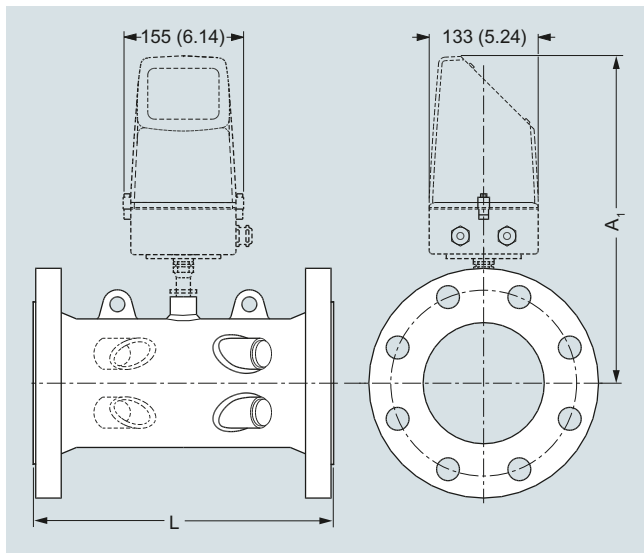

Transmitter IP67/NEMA 4X/6, wall mounting

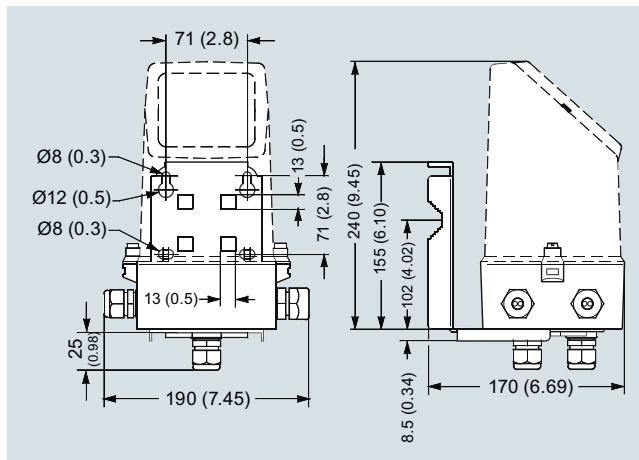

Dimensions in mm (inch)

Sensor dimensions for FUS380 and FUE380

Size	PN 16		PN 25		PN 40		A1	Lift hug
	L	Weight	L	Weight	L	Weight		
DN	mm	kg	mm	kg	mm	kg	mm	
50	-	-	-	-	300 +0/-2	10	350	No
65	-	-	-	-	300 +0/-2	15	363	No
80	-	-	-	-	350 +0/-2	18	370	No
100	350 +0/-2	15	-	-	350 +0/-2	18	372	No
125	350 +0/-2	18	-	-	350 +0/-2	24	385	No
150	500 +0/-3	28	-	-	500 +0/-3	34	399	No
200	500 +0/-3	38	500 +0/-3	47	500 +0/-3	55	425	Yes
250	600 +0/-3	60	600 +0/-3	76	600 +0/-3	91	452	Yes
300	500 +0/-3	66	500 +0/-3	81	-	-	478	Yes
350	550 +0/-3	94	550 +0/-3	121	-	-	495	Yes
400	600 +0/-3	124	600 +0/-3	153	-	-	520	Yes
500	625 +0/-3	194	625 +0/-3	231	-	-	570	Yes
600	750 +0/-3	303	750 +0/-3	365	-	-	622	Yes
700	875 +0/-3	361	875 +0/-3	553	-	-	673	Yes
800	1000 +0/-3	494	1000 +0/-3	770	-	-	724	Yes
900	1230 +0/-6	535	1300 +0/-6	835	-	-	775	Yes
1000	1300 +0/-6	594	1370 +0/-6	1000	-	-	826	Yes
1200	1360 +0/-6	732	-	-	-	-	928	Yes

Notes:

- Weight for transmitter/electronics 1.5 kg (compact version) or approximately 3 kg (remote version including 10 m cable set)
- Means not available
- All weights are **approximate**
- For flange values - see norm EN 1092-1

Dimensional drawings (continued)

Size	PN 16		PN 25		PN 40		A1	Lift hug
	L	Weight	L	Weight	L	Weight		
inch	inch	lb	inch	lb	inch	lb	inch	
2	-	-	-	-	11.81 +0/-0.08	22	13.78	No
2½	-	-	-	-	11.81 +0/-0.08	33	14.30	No
3	-	-	-	-	13.78 +0/-0.08	40	14.57	No
4	13.78 +0/-0.08	33	-	-	13.78 +0/-0.08	40	14.65	No
5	13.78 +0/-0.08	40	-	-	13.78 +0/-0.08	53	15.16	No
6	19.68 +0/-0.12	62	-	-	19.68 +0/-0.12	75	15.71	No
8	19.68 +0/-0.12	84	19.68 +0/-0.12	104	19.68 +0/-0.12	121	16.74	Yes
10	23.62 +0/-0.12	132	23.62 +0/-0.12	168	23.62 +0/-0.12	201	17.80	Yes
12	19.68 +0/-0.12	146	19.68 +0/-0.12	179	-	-	18.82	Yes
14	21.65 +0/-0.12	207	21.65 +0/-0.12	267	-	-	19.49	Yes
16	23.62 +0/-0.12	273	23.62 +0/-0.12	337	-	-	20.48	Yes
20	24.61 +0/-0.12	428	24.61 +0/-0.12	509	-	-	22.45	Yes
24	29.53 +0/-0.12	668	29.53 +0/-0.12	805	-	-	24.49	Yes
28	34.45 +0/-0.12	796	34.45 +0/-0.12	1246	-	-	26.50	Yes
32	39.37 +0/-0.12	1089	39.37 +0/-0.12	1698	-	-	28.51	Yes
36	48.43 +0/-0.24	1179	51.18 +0/-0.24	1841	-	-	30.52	Yes
40	51.18 +0/-0.24	1310	53.94 +0/-0.24	2205	-	-	32.52	Yes
48	53.34 +0/-0.24	1614	-	-	-	-	36.54	Yes

Notes:

- Weight for transmitter/electronics 3.3 lb (compact version) or approximately 6.6 lb (remote version including 32.8 ft cable set)
- Means not available
- All weights are **approximate**
- For flange values - see norm EN 1092-1

Flow Measurement

SITRANS FS (ultrasonic)

Inline ultrasonic flowmeters

SITRANS FUS380/FUE380 dimensional drawings and circuit diagrams

Circuit diagrams

3

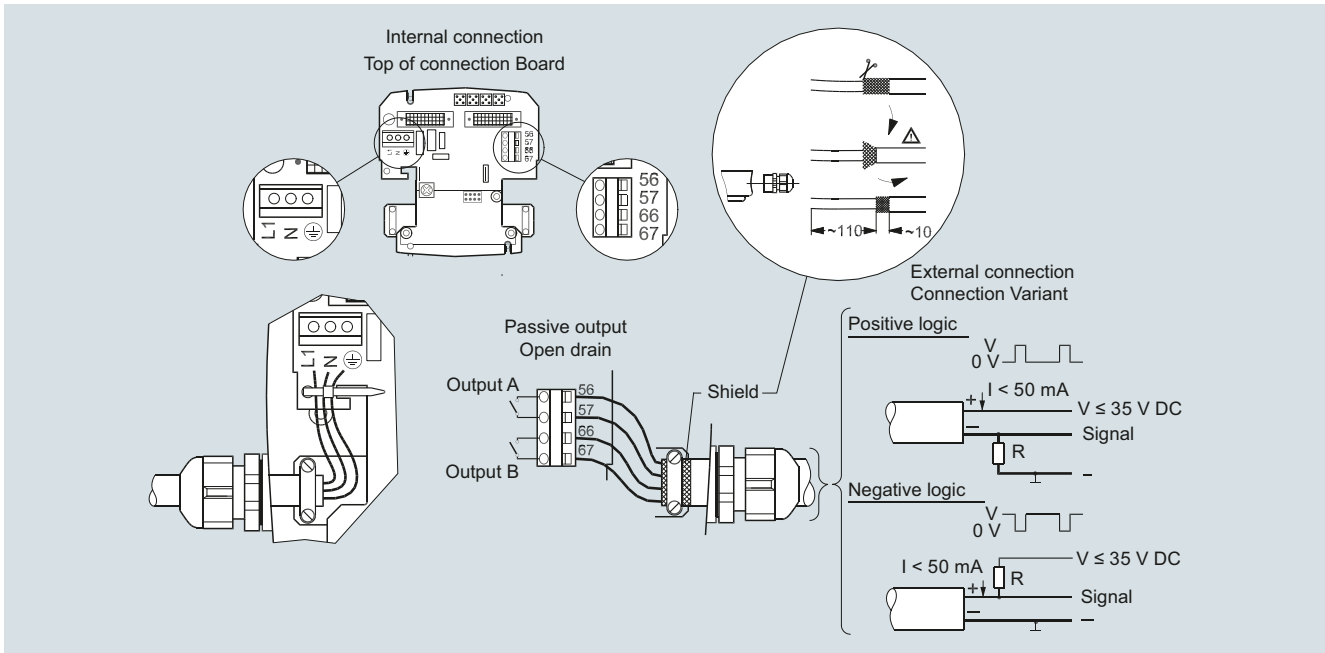

Electrical connection of transmitter SITRANS FUS380 and FUE380

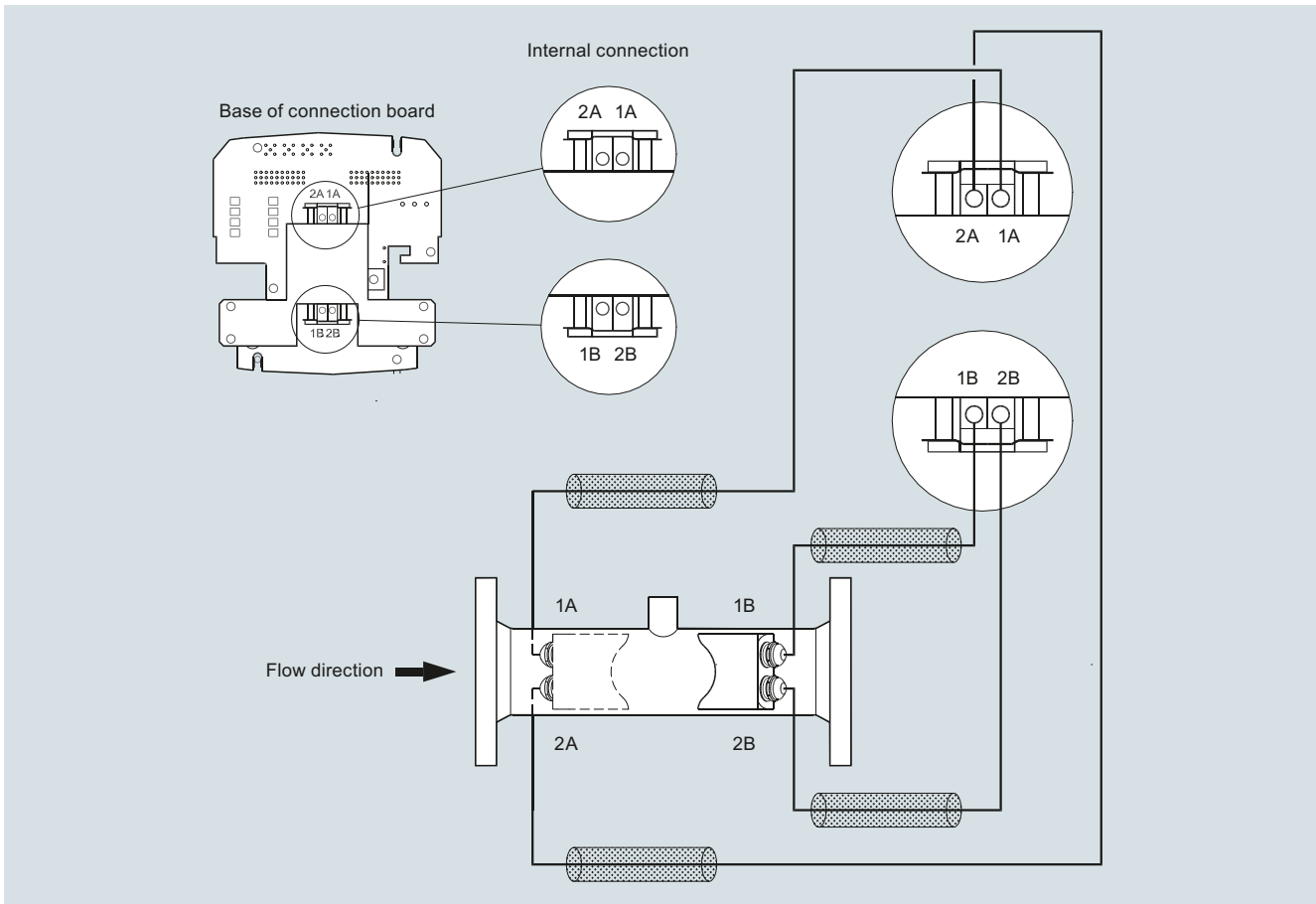

Electrical connection of sensor SITRANS FUS380 and FUE380