

Level measurement

Continuous level measurement
Guided wave radar transmitters

SITRANS LG series

Overview



The Siemens SITRANS LG series are guided wave radar transmitters for level, level/interface, and volume measurement of liquids and solids. The SITRANS LG product line can handle changes in process conditions, high temperatures and pressures, and steam.

Benefits

- High accuracy to +/- 2 mm
- Advanced Diagnostics available for high degree of safety
- Simple menu driven display offers ease of setup
- Large range of options offers reliability in most continuous level measurement applications
- Ease of maintenance through module design and field replaceable and adjustable probe options
- Perfect solution for wide range of applications from storage to interface with options for extreme pressure and temperature conditions
- Universally applicable in liquids, interface, slurries and solids
- Highly immune to buildup using auto learn function
- Ability to measure in loss of echo situations with probe end tracking
- Suitable for API 2350
- Convenient access using USB and remote interface accessories

Application

The SITRANS LG series comes in four different models, depending on the applications, level of performance, and functionality required:

- SITRANS LG240 offers configuration options for your hygienic and corrosive application requirements
- SITRANS LG250 Highly flexible solution for liquid level and interface applications. Extremely versatile offering solutions for storage, separation of materials or difficult ammonia applications
- SITRANS LG260 Ideal for measuring level in medium range solids applications including; grains, plastics, and cement
- SITRANS LG270 offers configuration options for extreme conditions including high temperature and high pressure applications such as: harsh applications found in chemical, HPI and energy industries for example, LPG gas tanks, steam boilers and distillation columns

Configuration

Mounting on nozzle

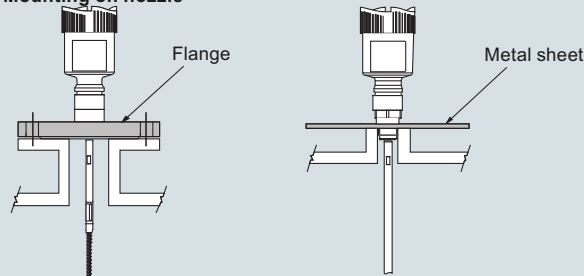

Installation in non-metal vessel

The guided microwave principle requires a metal surface on the process fitting. Therefore, use in plastic vessels etc. an instrument version with flange (from DN 50) or place a metal sheet, $\text{Ø} > 200$ mm (8 inch), beneath the process fitting when screwing it in. Make sure that the plate has direct contact with the process fitting

Mounting socket

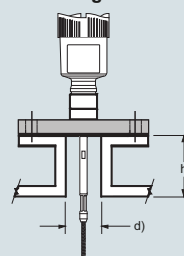

If possible, avoid sockets, mount the sensor flush with the vessel top. If this is not possible, use short sockets with small diameter. Higher sockets or sockets with a bigger diameter can generally be used. They simply increase the upper blocking distance. Check if this is relevant for your measurement. In such cases, always carry out a false signal suppression after installation.

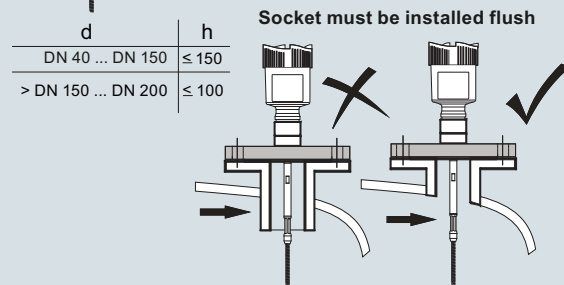

Socket must be installed flush

When welding the socket, make sure that the socket is flush to the vessel top. Before beginning the welding work, remove the electronics module from the sensor. By doing this, you avoid damage to the electronics through inductive coupling.

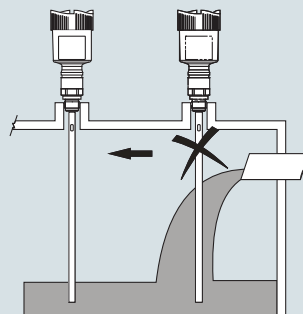

Inflowing medium

Do not mount the instruments in or above the filling stream. Make sure that you detect the product surface, not the inflowing product.

SITRANS LG Series installation

Configuration (continued)

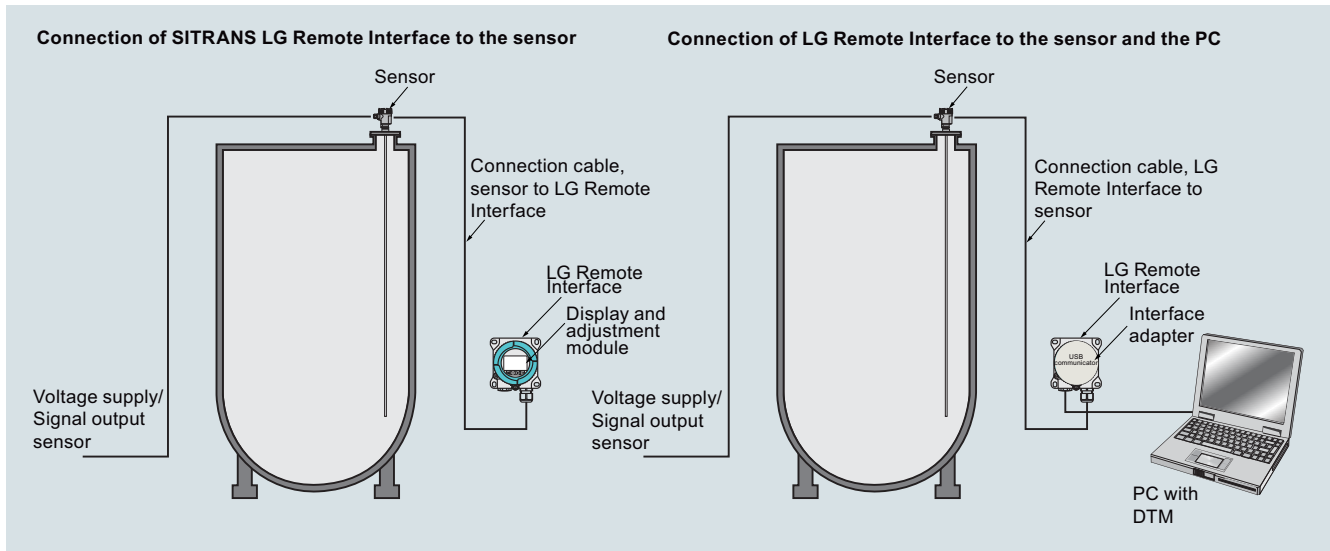

SITRANS LG Remote Interface installation

Level measurement

Continuous level measurement
Guided wave radar transmitters

SITRANS LG series

Technical specifications

Mode of operation

| | |
|---------------------|--|
| Measuring principle | Guided wave radar measurement |
| Measuring range | 300 ... 75 000 mm (11.81 ... 2 952.75 inch) |

Output

| | |
|---|--|
| mA analog output with HART digital signal | 4 ... 20 mA/HART (SIL optional) |
| Output range | |
| • Analog | Current: minimum 3.8 mA, maximum 20.5 mA |
| • Startup current | ≤ 10 mA for 5 ms after switching on, ≤ 3.6 mA |
| Diagnostic alarm | Failure signal current output (adjustable): last valid measured value, ≥ 21 mA, ≤ 3.6 mA |
| Digital communication | HART Version 7 x and multidrop compatible |
| Modbus | Modbus RTU, Modbus ASCII |
| PROFIBUS PA | PROFIBUS PA profile 3.02 |
| FOUNDATION Fieldbus | FOUNDATION Fieldbus protocol Physical layer according to IEC 61158-2 |

Performance

| | |
|------------------------------|---|
| • Measuring cycle time | Process reference conditions according to DIN EN 61298-1 < 500 ms |
| • Step response time | ≤ 3 s |
| • Temperature Effects | The measurement error from the process conditions is in the specified pressure and temperature range of below 1 % |
| Non-linearity | |
| • Coaxial | |
| • Single rod probes | |
| • Interface models | See manual for more details |
| Resolution and repeatability | Accuracy +/- 2 mm (0.08 inch) |
| Accuracy | |
| • Coaxial/rod/cable probes | +/- 2 mm (0.08 inch) |
| • Interface models | +/- 5 mm (0.197 inch) |
| | Note: Typical deviation, Interface measurement. See manual for full explanation. |

Rated operating conditions

| | |
|-----------------------------------|---|
| Ambient temperature for enclosure | -40 ... +80 °C (-40 ... +176 °F) |
| Storage temperature | -40 ... +80 °C (-40 ... +176 °F) |
| LCD readable temperature range | -40 ... +80 °C (-40 ... +176 °F) with display heated option |
| Location | Indoor/outdoor |
| Installation category | II |
| Pollution degree | 2 |
| Relative Humidity | 20 ... 85 % |

Medium conditions

| | |
|---------------------------|---|
| Dielectric constant | dK ≥ 1.4 (configuration dependent) Note: for measurement below 1.4 use probe end tracking. |
| Process temperature range | -196 ... +450 °C (-321 ... +842 °F) |
| Vessel pressure | -1 ... +400 bar (-100 ... +40 000 kPa) |

Design

| | |
|---|--|
| Instrument weight (dependent on process fitting) - see manual for further details | Approx. 0.8 ... 8 kg (0.176 ... 17.64 lb) |
| Materials | |
| • Enclosure | <ul style="list-style-type: none"> Plastic housing plastic PBT (Polyester) Aluminum die-cast housing, aluminum die-cast AISI10 mg, powder-coated- basis: polyester Stainless steel housing, precision casting 316L Stainless steel housing, electropolished 316L |
| • Degree of protection | <ul style="list-style-type: none"> Type 4/NEMA 4, IP65 Plastic housing IP66/IP67 Aluminum and stainless steel housings are IP66/68 |
| • Cable inlet | 2 x M20 x 1.5 or 2 x 1/2" NPT |
| Process connections | |
| • Pipe thread, cylindrical (ISO 228 T1) | G3/4" A, G1" A, G1 1/2" A according to DIN 3852-A |
| • American pipe thread, conical (ASME B1.20.1) | 3/4" NPT, 1" NPT, 1 1/2" NPT |
| • Flanged | DIN from DN 25, ASME from 1" |
| • Hygienic | Hygienic fittings |
| Process seal instrument side | FKM (SHS FPM 70C3 GLT), FFKM (Kalrez 6375), EPDM (A+P 70.10-02), silicone FEP coated (A+P FEPO-SEAL) or Borosilicate glass GPC 540 |
| Second line of defense (glass seal) (optional) | Borosilicate glass GPC 540 Note: The second line of defense is a second level of the process separation in the form of a gas-tight feedthrough in the lower part of the housing, preventing product from penetrating into the housing. |
| Programming | |
| Local | Four button, menu-driven data entry |
| Handheld communicator | Hart communicator |
| PC | SIMATIC PDM, AMS, PACTware |
| Power | |
| 2-wire Hart version | 9.6 ... 35 V DC |
| 4-wire versions | 9.6 ... 48 V DC, 20 ... 42 V AC, 50/60 Hz, and 90 ... 253 V AC, 50/60 Hz |
| Modbus | 8 ... 30 V DC |
| PROFIBUS PA | 9 ... 32 V DC |
| FOUNDATION Fieldbus | 9 ... 32 V DC |
| | Note: see manual for specific power based on ordered options |
| Certificates and approvals | |
| Hazardous approvals: | ATEX, FM, CSA, IECEx Note: other regional approvals are available |
| Hygienic approvals: | EHDG, FDA |
| Overflow protection | WHG, Vlare |
| Ship approval | ABS, CCS, GL, BV, LR |

Technical specifications (continued)

| | SITRANS LG240 | SITRANS LG250 | SITRANS LG260 | SITRANS LG270 |
|--------------------------------------|--|--|--|--|
| Industries | Food, Beverage and Pharmaceutical | Chemical/HPI/Power/General | Cement, power generation, food, processing, mineral processing, mining | Chemical/HPI/Power/General |
| Applications | Hygienic and corrosive applications | Liquids, storage and process vessels with agitators, vaporous liquids, interface | Cement, fly ash, grain, coal, flour, plastics | Aggressive applications in liquids, storage and process vessels with agitators, vaporous liquids, high temperatures and pressures, low dielectric media |
| Range | 32 m | 75 m | 60 m | 60 m |
| Performance | ± 2 mm | ± 2 mm | ± 2 mm | ± 2 mm |
| Temperature | -40 ... +150 °C (-40 ... +302 °F) | -40 ... +200 °C (-40 ... +392 °F) | -40 ... +200 °C (-40 ... +392 °F) | -196 ... +450 °C (-320.8 ... +842 °F) |
| Process pressure | | | | |
| Standard version | - | -1 ... +40 bar/ -100 ... +4 000 kPa (-14.5 ... +580 psig), depending on the process fitting | - | - |
| With borosilicate glass lead-through | - | -1 ... +100 bar/ -100 ... +10 000 kPa (-14.5 ... +1 450 psig), depending on the process fitting | - | - |
| Communications | <ul style="list-style-type: none"> • 4 ... 20 mA/HART • Modbus: Modbus RTU, Modbus ASCII • PROFIBUS PA • FOUNDATION Fieldbus • SIMATIC PDM • DTM/FDT for PACTware • Fieldcare | <ul style="list-style-type: none"> • 4 ... 20 mA/HART • Modbus: Modbus RTU, Modbus ASCII • PROFIBUS PA • FOUNDATION Fieldbus • SIMATIC PDM • DTM/FDT for PACTware • Fieldcare | <ul style="list-style-type: none"> • 4 ... 20 mA/HART • Modbus: Modbus RTU, Modbus ASCII • PROFIBUS PA • FOUNDATION Fieldbus • SIMATIC PDM • DTM/FDT for PACTware • Fieldcare | <ul style="list-style-type: none"> • 4 ... 20 mA/HART • Modbus: Modbus RTU, Modbus ASCII • PROFIBUS PA • FOUNDATION Fieldbus • SIMATIC PDM • DTM/FDT for PACTware • Fieldcare |

Level measurement

Continuous level measurement
Guided wave radar transmitters

SITRANS LG series

Selection and ordering data

Article No.

Article No.

| SITRANS LG240 Guided radar level transmitter | 7ML5880- | Ord. code |
|---|------------|-----------|
| Continuous, contact, 32 m (105 ft) range. Monitors level and interface in aggressive liquids. Ideal for hygienic applications. | | |
| Click on the Article No. for the online configuration in the PIA Life Cycle Portal. | | |
| Approvals | | |
| General purpose (CSA, FM, CE) | 0 A | |
| Overfill protection (WHG; VLAREM) ¹¹⁾ | 0 C | |
| ATEX II 1G, ½G, 2G Ex ia IIC T6 ¹⁴⁾ | 0 E | |
| ATEX II 1G, ½G, 2G Ex ia IIC + Overfill (WHG; VLAREM) ¹¹⁾ | 0 F | |
| ATEX II 1G, ½G 2G Ex ia IIC + ATEX II 1D, ½D, 2D IP6x ¹⁾¹⁵⁾¹⁷⁾ | 0 H | |
| ATEX II ½G, 2G Ex d ia IIC T6 ³⁾¹³⁾¹⁶⁾ | 0 J | |
| ATEX II ½G, 2G Ex d ia IIC + ATEX II ½D, 2D IP6x ³⁾¹³⁾¹⁶⁾¹⁷⁾ | 0 K | |
| ATEX II 1D, ½D, 2D IP6x ¹⁾¹⁷⁾¹⁸⁾ | 0 N | |
| ATEX II 1G, II ½G, II 2G Ex ia IIC T6 ... T1 Ga, Ga/Gb, Gb /IEC Ex ia IIC T6 ... T1 Ga, Ga/Gb, Gb ¹⁾¹⁴⁾ | 0 W | |
| IEC Ex ia IIC T6 ¹⁴⁾ | 0 P | |
| IEC Ex ia IIC T6 + IEC IP6x T tD ¹⁾¹⁵⁾¹⁷⁾ | 0 Q | |
| IEC Ex d ia IIC T6 ³⁾¹³⁾¹⁶⁾ | 0 R | |
| IEC Ex d ia IIC T6 + IEC IP6x T tD ³⁾¹³⁾¹⁶⁾ | 0 S | |
| FM (NI) Class I, Div. 2, Groups A, B, C, D2 ⁹⁾¹²⁾¹⁶⁾ | 1 A | |
| FM (IS) Class I, II, III, Div. 1, Groups A, B, C, D, E, F, G ⁹⁾¹⁵⁾ | 1 B | |
| FM (XP-AIS) Class I, II, III, Div. 1, Groups A, B, C, D, E, F, G ³⁾¹³⁾¹⁶⁾ | 1 C | |
| CSA (NI) Class I, Div. 2, Groups A, B, C, D; (DIP) Class II, III, Div. 1, Groups E, F, G ¹⁾¹⁷⁾ | 1 E | |
| CSA (IS) Class I, II, III, Div. 1, Groups A, B, C, D, E, F, G ¹⁴⁾ | 1 F | |
| CSA (XP-IS) Class I, II, III, Div. 1, Groups A, B, C, D, E, F, G ³⁾¹³⁾¹⁶⁾ | 1 G | |
| NEPSI Ex ia IIC T6 ¹⁴⁾ | 2 A | |
| NEPSI Ex ia IIC T6 + DIP A20/21 TA T* ¹⁾¹⁵⁾ | 2 B | |
| NEPSI Ex d ia IIC T6 ⁹⁾¹⁰⁾¹³⁾¹⁶⁾ | 2 C | |
| NEPSI Ex d ia IIC T6 + DIP A20/21 TA T* ⁹⁾¹⁰⁾¹³⁾¹⁶⁾ | 2 D | |
| NEPSI DIP A20/21 TA T* ¹⁾¹⁶⁾ | 2 G | |
| INMETRO Ex ia IIC T6 ... T1 ¹⁴⁾ | 3 A | |
| INMETRO Ex t IIIC T* IP6X, Da, Da/Db, Da/Dc, Db + Ex ia IIC T6, Ga, Ga/Gb ¹⁾¹⁰⁾¹⁵⁾ | 3 B | |
| INMETRO Ex d ia IIC T6 ... T1 ⁹⁾¹⁰⁾¹³⁾¹⁶⁾ | 3 C | |
| INMETRO Ex t IIIC T* IP6X, Da, Da/Db, Da/Dc, Db + Ex d ia IIC T6 Ga/Gb ⁹⁾¹⁰⁾¹³⁾¹⁶⁾ | 3 D | |
| INMETRO Ex t IIIC T* IP6X, Da, Da/Db, Da/Dc, Db ¹⁾¹⁰⁾¹³⁾¹⁶⁾ | 3 G | |
| Korea KC ex free area | 6 A | |
| GOST-R/EAC 0 Ex ia IIC T1 ... T6 X ¹⁴⁾ | 5 A | |
| GOST-R/EAC 0 Ex ia IIC T1 ... T6 X + Ex t IIIC T ... IP66 ¹⁾¹⁵⁾ | 5 B | |
| GOST-R/EAC 1 Ex d ia IIC T1 ... T6 X ⁹⁾¹⁰⁾¹³⁾¹⁶⁾ | 5 C | |
| GOST-R/EAC 1 Ex d ia IIC T1 ... T6 X + Ex t IIIC T ... IP66 ⁹⁾¹⁰⁾¹³⁾¹⁶⁾ | 5 D | |
| Note: Version/Material, Process fitting/ Material, and Length options are available only with options of corresponding type. | | |
| Probe version/Material | | |
| Probe cable ø 4 mm (0.16 inch) with gravity weight/PFA ¹⁷⁾ | A | |
| Probe exchangeable rod ø 8 mm (0.31 inch)/1.4435 (Basle standard) ¹⁷⁾ | B | |
| Probe exchangeable rod ø 8 mm (0.31 inch)/ 1.4435 (Basle standard) can be autoclaved ¹⁷⁾ | C | |
| Probe rod ø 10 mm (0.39 inch)/PFA ¹⁷⁾ | D | |
| Probe exchangeable rod (ø 8 mm) /1.4435 (BN2), electropolished (Ra < 0.38 µm) ¹⁷⁾ | E | |

| SITRANS LG240 Guided radar level transmitter | 7ML5880- | Ord. code |
|--|------------|-----------|
| Continuous, contact, 32 m (105 ft) range. Monitors level and interface in aggressive liquids. Ideal for hygienic applications. | | |
| Process fitting/Material | | |
| Clamp 2" PN 16 (ø 64 mm) DIN 32676, ISO2852/1.4435 (BN2) | 0 0 | |
| Clamp 2" PN 16 (ø 64 mm) DIN 32676, ISO2852/PTFE-TFM 1600 | 0 1 | |
| Clamp 2 1/2" PN 10 (ø 77.5 mm) DIN 32676, ISO2852/1.4435 (BN2) | 0 2 | |
| Clamp 2 1/2" PN 10 (ø 77.5 mm) DIN 32676, ISO2852/PTFE-TFM 1600 | 0 3 | |
| Clamp 3" PN 10 (ø 91 mm) D N 32676, ISO2852/1.4435 (BN2) | 0 4 | |
| Clamp 3" PN 10 (ø 91 mm) DIN 32676, ISO2852/PTFE-TFM 1600 | 0 5 | |
| Clamp 4" PN 6 (ø 119 mm) DIN 32676, ISO2852/1.4435(BN2) | 0 6 | |
| Clamp 4" PN 6 (ø 119 mm) DIN 32676, ISO2852/PTFE-TFM 1600 | 0 7 | |
| Clamp 1½" PN 16 (ø 50.5 mm) DIN 32676, ISO2852/1.4435 (BN2) | 4 0 | |
| Bolting DN 32, PN 40 DIN 11851/1.4435(BN2) | 0 8 | |
| Bolting DN 32, PN 40 DIN 11851/PTFE-TFM 1600 | 1 0 | |
| Bolting DN 40, PN 40 DIN 11851/1.4435 (BN2) | 1 1 | |
| Bolting DN 40, PN 40 DIN 11851/PTFE-TFM 1600 | 1 2 | |
| Bolting DN 50, PN 25 DIN 11851/1.4435(BN2) | 1 3 | |
| Bolting DN 50, PN 25 DIN 11851/PTFE-TFM 1600 | 1 4 | |
| Bolting DN 65, PN 25 DIN 11851/PTFE-TFM 1600 | 1 5 | |
| Flange DN 25, PN 40 Form C, DIN 2501/PTFE-TFM 1600 | 2 0 | |
| Flange DN 40, PN 40 Form C, DIN 2501/PTFE-TFM 1600 | 2 1 | |
| Flange DN 50, PN 40 Form C, DIN 2501/PTFE-TFM 1600 | 2 2 | |
| Flange DN 50, PN 40 Form V13, DIN 2513/PTFE-TFM 1600 | 2 3 | |
| Flange DN 65, PN 40 Form C, DIN 2513/PTFE-TFM 1600 | 2 4 | |
| Flange DN 80, PN 40 Form C, DIN 2501/PTFE-TFM 1600 | 2 5 | |
| Flange DN 100, PN 16 Form C, DIN 2501/PTFE-TFM 1600 | 2 6 | |
| Flange DN 80, PN 40 EN 1092-1 Form B1/PTFE-TFM 1600 | 2 7 | |
| Flange DN 100, PN 40 EN 1092-1 Form B1/PTFE-TFM 1600 | 2 8 | |
| Flange 2" 150 lb RF, ASME B16.5/PTFE-TFM 1600 | 3 0 | |
| Flange 2" 300 lb RF, ASME B16.5/PTFE-TFM 1600 | 3 1 | |
| Flange 3" 150 lb RF, ASME B16.5/PTFE-TFM 1600 | 3 2 | |
| Flange 4" 150 lb RF, ASME B16.5/PTFE-TFM 1600 | 3 3 | |
| Note: The pressure limit for all PTFE coated versions is 16 bar (per manual). | | |



Level measurement

Continuous level measurement
Guided wave radar transmitters

SITRANS LG series

Selection and ordering data

Order code

Further designs (mandatory)

Please add "-Z" to Article No. and specify Order code(s).

Supplementary electronics

Without **A00**
Additional current output 4 ... 20 mA¹⁰⁾ **A01**

Indicating/adjustment module

Without **E00**
Mounted **E01**
Laterally mounted **E02**

Language of display

German **L00**
English **L01**
French **L02**
Dutch **L03**
Italian **L04**
Spanish **L05**
Portuguese **L06**
Russian **L07**
Chinese **L08**
Japanese **L09**
No language pre-set **L10**

Operating instructions

German **M00**
English **M01**
French **M02**
Spanish **M03**

Further designs (optional)

Please add "-Z" to Article No. and specify Order code(s).

Enter the total insertion length in plain text description **Y01**

Enter the total length of rigid part (cable version only) range from 100 ... 1 000 mm **Y02**

Cleaning included certificate: oil, grease and silicone free **W01**

Remote electronic cable lengths: 2 m (6.6 ft). Only available with Housing options Q2A and Q2B **Y10**

Remote electronic cable lengths: 5 m (16.4 ft). Only available with Housing options Q2A and Q2B **Y11**

Remote electronic cable lengths: 10 m (32.8 ft). Only available with Housing options Q2A and Q2B **Y12**

Identification label (measurement loop) stainless steel, 40 characters max, add in plain text. To add more than one line use a coma ",", for line break. **Y17**

Identification Label (measurement loop) foil, 40 characters max, add in plain text. To add more than one line use a coma ",", for line break. **Y18**

Material Inspection certificate 3.1 of EN 10204 **C05**

3.1-Inspection Certificate for instrument (EN 10204)⁸⁾ **C12**

Inspection certificate 3.1 (EN 10204, NACE MR 0175) - material⁸⁾¹⁹⁾ **D07**
Note: 316L probes include NACE MR 0175 and MR 0103, non 316L probes include MR 0175 only and plated flange designs are not available with NACE certificate.

3.1-Inspection Certificate for instrument with test data (EN 10204)⁹⁾ **C25**

2.2-Factory certificate for material (EN 10204)⁸⁾ **C15**

Quality and test plan⁸⁾ **C26**

Dye penetration test, results confirmed via a 3.1 certificate/instrument (EN10204)⁹⁾ **C13**

Further designs (optional)

Please add "-Z" to Article No. and specify Order code(s).

X-ray test + 3.1 certificate/instrument⁸⁾ **C14**

Positive material identification test + 3.1 certificate/instrument⁸⁾ **C16**

Roughness test + 3.1 certificate/instrument⁸⁾ **C18**

Pressure test + 3.1 certificate/instrument⁸⁾ **C31**

Helium leak test + 3.1 certificate/instrument⁸⁾ **C32**

Ferrite measuring accuracy to DIN 32514-1 + 3.1 certificate/instrument⁸⁾ **C60**

Pressure test according to Norsok + 3.1 certificate/instrument⁸⁾ **C61**

5 point calibration certificate (min. length 300 mm)⁸⁾ **C62**

Operating Instructions

All literature is available to download for free, in a range of languages, at

<http://www.siemens.com/processinstrumentation/documentation>

Accessories

SITRANS LG series/SITRANS RD150 sensor display module **Article No. A5E34143449**

SITRANS LG, two-wire 4 ... 20 mA/HART electronic **A5E35637821**

SITRANS LG, USB communicator **A5E35192015**

SITRANS LG, Mounting eye M12 x 20 **PBD:51041448**

SITRANS LG, Mounting spring **PBD:51041449**

Siemens Intrinsically Safe Barrier (DC powered), ATEX II 1 G EEx ia **7NG4124-0AA00**

SITRANS RD100, loop powered display - see Chapter 7 **7ML5741-.....-**

SITRANS RD150, remote digital display for 4 ... 20 mA and HART devices - see Chapter 7 **7ML5742-.....-....**

SITRANS RD200, universal input display with Modbus conversion - see Chapter 7 **7ML5740-.....-....**

SITRANS RD300, dual line display with totalizer and linearization curve and Modbus conversion - see Chapter 7 **7ML5744-.....-....**

For applicable back up point level switch - see point level measurement section

Note: some configuration options are not available.

For restriction information see the online PIA configuration tool.

Please consult manual for further detail.

- 1) Some approvals are not available with Plastic and Stainless steel (electropolished) Housing/Protection/Cable options and certain glands.
- 2) Available only with Rod \varnothing 10 mm/PFA and Cable \varnothing 4 mm/PFA Length options.
- 3) Available only with Supplementary electronic option A00 and Indicating/adjustment module options E00, E01.
- 4) Not available with Remote Housing/Protection/Cable options Q2A and Q2B.
- 5) Not available with Electronic option 5.
- 6) Not available with Y02.
- 7) Available only with Electronic options 0, 2, and 6.
- 8) Listed Certificates are not available with all configurations, contact factory.
- 9) Available only with Supplementary electronic option A00.
- 10) Not available with Indicating/adjustment module option E02.
- 11) Available only with Electronics options 0, 2, and 5.
- 12) Some approvals are not available with Remote or Stainless steel (electropolished) Housing/Protection/Cable options and certain glands.
- 13) Available only with Double chamber, Metallic Housing/Protection/Cable options and certain glands.
- 14) Available only with Electronics options 0, 2, 5, 6.
- 15) Available only with Electronics options 0 and 2.
- 16) Available only with Electronics options 0 ... 4.
- 17) Not available with some Seal/Process Temperature options.
- 18) Available only with Electronic options 0, 2, 3, and 4.
- 19) Available only with 316L Probes. NACE is not available with coated, plated, or hygienic connections.

| Selection and ordering data | Article No. | Article No. |
|--|-----------------|-----------------|
| SITRANS LG250 Guided radar level transmitter | 7ML5881- | 7ML5881- |
| Continuous, contact, 75 m (246 ft) range. Monitors level and interface in liquids. | Ord. code | Ord. code |
| ↗ Click on the Article No. for the online configuration in the PIA Life Cycle Portal. | | |
| Approvals | | |
| General purpose (CSA, FM, CE) | 0 A | 1 H |
| Shipping approval ⁽⁴⁾⁽⁶⁾⁽⁷⁾⁽⁸⁾⁽¹³⁾ | 0 B | 7 K |
| Overfill protection (WHG; VLAREM) ⁽⁹⁾⁽¹⁰⁾⁽¹³⁾ | 0 C | 7 L |
| ATEX II 1G, ½G, 2G Ex ia IIC T6 ⁽¹⁰⁾⁽¹³⁾ | 0 E | 7 M |
| ATEX II 1G, ½G, 2G Ex ia IIC + Overfill (WHG; VLAREM) ⁽¹⁰⁾⁽¹³⁾ | 0 F | 7 N |
| ATEX II 1G, ½G, 2G Ex ia IIC T6 + shipping approval ⁽⁴⁾⁽⁶⁾⁽⁷⁾⁽⁸⁾⁽¹³⁾ | 0 G | 2 A |
| ATEX II 1G, ½G, 2G Ex ia IIC + ATEX II 1D, ½D, 2D IP6x ⁽¹⁾⁽¹³⁾ | 0 H | 2 B |
| ATEX II ½G, 2G Ex d ia IIC T6 ⁽²⁾⁽⁸⁾⁽¹¹⁾⁽¹²⁾⁽¹³⁾ | 0 J | 2 C |
| ATEX II 1/2G, 2G Ex d ia IIC + ATEX II 1/2D, 2D IP6x ⁽²⁾⁽⁸⁾⁽¹¹⁾⁽¹²⁾⁽¹³⁾ | 0 K | 2 D |
| ATEX II 1/2G, 2G Ex d IIC T6 ⁽¹⁾⁽¹¹⁾⁽¹⁴⁾ | 0 L | 2 E |
| ATEX II 1/2G, 2G Ex d IIC + ATEX II 1/2D, 2D IP6x ⁽¹⁾⁽¹¹⁾⁽¹³⁾⁽¹⁴⁾ | 0 M | 2 F |
| ATEX II 1D, 1/2D, 2D IP6x T ⁽¹⁾⁽¹³⁾⁽¹⁴⁾ | 0 N | 2 G |
| ATEX II 1G, II 1/2G, II 2G Ex ia IIC T6...T1 Ga, Ga/Gb, Gb / IEC Ex ia IIC T6...T1 Ga, Ga/Gb, Gb ⁽¹³⁾ | 0 W | 3 A |
| ATEX II 1/2G, II 2G Ex db IIC T6 ... T1 Ga/Gb, Gb / IEC Ex db IIC T6 ... T1 Ga/Gb, Gb ⁽¹³⁾⁽¹⁴⁾⁽¹⁸⁾ | 1 K | 3 B |
| ATEX II 1/2G, II 2G Ex d ia IIC T6 ... T1 Ga/Gb, Gb + Ship approval ⁽²⁾⁽⁶⁾⁽⁸⁾⁽¹¹⁾⁽¹²⁾⁽¹³⁾ | 7 A | 3 C |
| ATEX II 1/2G, II 2G Ex db IIC T6 ... T1 Ga/Gb, Gb + Ship approval ⁽¹⁾⁽⁶⁾⁽⁸⁾⁽¹¹⁾⁽¹³⁾ | 7 B | 3 D |
| ATEX II 1/2G, II 2G Ex db IIC T6 ... T1 Ga/Gb, Gb + Overfill protection (WHG, VLAREM) ⁽¹⁾⁽¹¹⁾⁽¹⁴⁾ | 7 P | 3 E |
| IEC Ex ia IIC T6 ⁽¹⁰⁾⁽¹³⁾ | 0 P | 3 F |
| IEC Ex ia IIC T6 + IEC IP6x T tD ⁽¹⁾⁽¹⁴⁾⁽¹⁵⁾ | 0 Q | 3 G |
| IEC Ex d ia IIC T6 ⁽²⁾⁽⁸⁾⁽¹¹⁾⁽¹²⁾⁽¹³⁾ | 0 R | 4 A |
| IEC Ex d ia IIC T6 + IEC IP6x T tD ⁽²⁾⁽⁸⁾⁽¹¹⁾⁽¹²⁾⁽¹³⁾⁽¹⁵⁾ | 0 S | 6 A |
| IEC Ex d IIC T6 ⁽¹⁾⁽¹¹⁾⁽¹⁴⁾ | 0 T | 5 A |
| IEC Ex d IIC T6 + IEC IP6x T tD ⁽¹⁾⁽¹¹⁾⁽¹⁴⁾ | 0 U | 5 B |
| IEC Ex db IIC T6...T1 Ga/Gb, Gb + Ship approval ⁽¹⁾⁽⁶⁾⁽⁸⁾⁽¹¹⁾⁽¹³⁾⁽¹⁴⁾ | 7 C | 5 C |
| IEC Ex ia IIC T6...T1 Ga, Ga/Gb, Gb + Ship approval ⁽⁶⁾⁽⁸⁾⁽¹³⁾⁽¹⁶⁾ | 7 D | 5 D |
| IEC Ex d ia IIC T6...T1 Ga/Gb, Gb + Ship approval ⁽²⁾⁽⁶⁾⁽⁸⁾⁽¹¹⁾⁽¹³⁾⁽¹⁵⁾ | 7 E | 5 E |
| FM (NI) Class I, Div. 2, Groups A, B, C, D ⁽³⁾⁽⁸⁾⁽¹³⁾⁽¹⁷⁾ | 1 A | 5 F |
| FM (IS) Class I, II, III, Div. 1, Groups A, B, C, D, E, F ⁽⁵⁾⁽⁸⁾⁽¹³⁾ | 1 B | 5 G |
| FM (XP-AIS) Class I, II, III, Div. 1, Groups A, B, C, D, E, F, G ⁽²⁾⁽⁸⁾⁽¹¹⁾⁽¹²⁾⁽¹³⁾ | 1 C | |
| FM (XP) Class I, Div. 1, Groups A, B, C, D ⁽²⁾⁽¹¹⁾⁽¹³⁾⁽¹⁴⁾ | 1 D | |
| FM (NI) Class I, II, III, Div. 2, Groups A, B, C, D, F, G + Ship approval ⁽⁴⁾⁽⁶⁾⁽⁸⁾⁽¹³⁾⁽¹⁷⁾ | 7 F | |
| FM (IS) Class I, II, III, Div. 1, Groups A, B, C, D, E, F, G + Ship approval ⁽⁶⁾⁽⁸⁾⁽¹³⁾⁽¹⁶⁾ | 7 G | |
| FM (XP-AIS) Class I, Div. 1, Groups A, B, C, D + Ship approval ⁽⁶⁾⁽⁸⁾⁽¹¹⁾⁽¹³⁾⁽¹⁶⁾ | 7 H | |
| FM (XP) Class I, Div. 1, Groups A, B, C, D + Ship approval ⁽²⁾⁽⁶⁾⁽⁸⁾⁽¹³⁾⁽¹⁴⁾ | 7 J | |
| CSA (NI) Class I, Div. 2, Groups A, B, C, D (DIP) Class II, III, Div. 1, Groups E, F, G ⁽¹⁾ | 1 E | |
| CSA (IS) Class I, II, III, Div. 1, Groups A, B, C, D, E, F, G ⁽⁵⁾⁽¹³⁾ | 1 F | |
| CSA (XP-IS) Class I, II, III, Div. 1, Groups A, B, C, D, E, F, G ⁽²⁾⁽⁸⁾⁽¹¹⁾⁽¹²⁾⁽¹³⁾ | 1 G | |
| SITRANS LG250 Guided radar level transmitter | 7ML5881- | 7ML5881- |
| Continuous, contact, 75 m (246 ft) range. Monitors level and interface in liquids. | Ord. code | Ord. code |
| CSA (XP) Class I, II, III, Div. 1, Groups A, B, C, D, E, F, G ⁽³⁾⁽¹³⁾⁽¹⁴⁾⁽¹⁸⁾ | 1 H | |
| CSA (NI) Class I, II, III Div. 2, Groups A, B, C, D, F, G + Ship approval ⁽¹⁾⁽⁶⁾⁽¹³⁾ | 7 K | |
| CSA (IS) Class I, II, III, Div. 1, Groups A, B, C, D, E, F, G + Ship approval ⁽⁶⁾⁽¹³⁾⁽¹⁶⁾ | 7 L | |
| CSA (XP-IS) Class I, II, III, Div. 1, Groups A, B, C, D, E, F, G + Ship approval ⁽⁶⁾⁽⁸⁾⁽¹¹⁾⁽³²⁾ | 7 M | |
| CSA (XP) Class I, II, III, Div. 1, Groups A, B, C, D, E, F, G + Ship approval ⁽⁶⁾⁽⁸⁾⁽¹³⁾⁽¹⁴⁾⁽¹⁸⁾ | 7 N | |
| NEPSI Ex ia IIC T6 ⁽⁵⁾⁽¹³⁾ | 2 A | |
| NEPSI Ex ia IIC T6 + DIP A20/21 TA T* ⁽¹⁾⁽¹³⁾ | 2 B | |
| NEPSI Ex d ia IIC T6 ⁽²⁾⁽⁸⁾⁽¹¹⁾⁽¹³⁾ | 2 C | |
| NEPSI Ex d ia IIC T6 + DIP A20/21 TA T* ⁽²⁾⁽⁸⁾⁽¹¹⁾⁽¹³⁾ | 2 D | |
| NEPSI Ex d IIC T6 ⁽¹⁾⁽¹¹⁾⁽¹³⁾⁽¹⁴⁾ | 2 E | |
| NEPSI Ex d IIC T6 + DIP A20/21 TA T* ⁽¹⁾⁽¹¹⁾⁽¹³⁾⁽¹⁴⁾ | 2 F | |
| NEPSI DIP A20/21 TA T* ⁽¹⁾⁽¹³⁾⁽¹⁴⁾ | 2 G | |
| INMETRO Ex ia IIC T6 ... T1 ⁽⁵⁾⁽¹³⁾ | 3 A | |
| INMETRO Ex t IIIC T* IP6X, Da, Da/Db, Da/Dc, Db + Ex ia IIC T6, Ga, Ga/Gb ⁽¹⁾⁽¹¹⁾⁽¹³⁾ | 3 B | |
| INMETRO Ex d ia IIC T6 ... T1 ⁽²⁾⁽⁸⁾⁽¹¹⁾⁽¹³⁾ | 3 C | |
| INMETRO Ex t IIIC T* IP6X, Da, Da/Db, Da/Dc, Db + Ex d ia IIC T6 Ga/Gb ⁽¹⁾⁽⁸⁾⁽¹¹⁾⁽¹³⁾ | 3 D | |
| INMETRO Ex d IIC T6 ... T1 ⁽¹⁾⁽¹¹⁾⁽¹³⁾⁽¹⁴⁾ | 3 E | |
| INMETRO Ex t IIIC T* IP6X, Da, Da/Db, Da/Dc, Db + Ex d IIC T6 Ga/Gb ⁽¹⁾⁽¹¹⁾⁽¹³⁾⁽¹⁴⁾ | 3 F | |
| INMETRO Ex t IIIC T* IP6X, Da, Da/Db, Da/Dc, Db ⁽¹⁾⁽¹¹⁾⁽¹³⁾⁽¹⁴⁾ | 3 G | |
| KOSHA Ex d IIC T6 ... T1 - KE ⁽¹⁾⁽¹¹⁾⁽¹³⁾⁽¹⁴⁾ | 4 A | |
| Korea KC ex free area | 6 A | |
| GOST-R/EAC 0 Ex ia IIC T1 ... T6 X ⁽¹³⁾ | 5 A | |
| GOST-R/EAC 0 Ex ia IIC T1 ... T6 X + Ex t IIIC T ... IP66 ⁽¹⁾⁽¹³⁾ | 5 B | |
| GOST-R/EAC 1 Ex d ia IIC T1 ... T6 X ⁽²⁾⁽⁸⁾⁽¹¹⁾⁽¹³⁾ | 5 C | |
| GOST-R/EAC 1 Ex d ia IIC T1 ... T6 X + Ex t IIIC T ... IP66 ⁽²⁾⁽⁸⁾⁽¹¹⁾⁽¹³⁾ | 5 D | |
| GOST-R/EAC 1 Ex d IIC T1 ... T6 X ⁽¹⁾⁽¹¹⁾⁽¹³⁾ | 5 E | |
| GOST-R/EAC 0 Ex d IIC T1 ... T6 X + Ex t IIIC T ... IP66 ⁽¹⁾⁽¹¹⁾⁽¹³⁾ | 5 F | |
| GOST-R/EAC Ex t IIIC T ... IP66 ⁽¹⁾⁽¹³⁾ | 5 G | |
| Note: Version/Material, Process fitting/Material, and Length options are available only with options of corresponding type. | | |
| Probe version/Material | | |
| Probe exchangeable cable ø 2 mm (0.08 inch) with gravity weight/316 ⁽¹⁹⁾⁽²⁰⁾ | A | |
| Probe exchangeable cable ø 2 mm (0.08 inch) center weight/316L ⁽¹⁹⁾⁽²⁰⁾ | B | |
| Probe exchangeable cable ø 4 mm (0.16 inch) with gravity weight/316L ⁽⁹⁾⁽¹⁹⁾⁽²⁰⁾ | C | |
| Probe exchangeable cable ø 4 mm (0.16 inch) with center weight/316L ⁽⁹⁾⁽¹⁹⁾⁽²⁰⁾ | D | |
| Probe exchangeable rod ø 8 mm (0.31 inch)/316L ⁽⁹⁾⁽¹⁹⁾ | E | |
| Probe exchangeable rod ø 12 mm (0.47 inch)/316L ⁽⁹⁾⁽¹⁹⁾ | F | |
| Probe coax version ø 21.3 mm (0.84 inch) with single hole/316L ⁽⁹⁾⁽¹⁹⁾⁽²⁰⁾ | G | |
| Probe coax version ø 21.3 mm (0.84 inch) with multiple hole/316L ⁽¹⁹⁾⁽²⁰⁾ | H | |
| Probe coax version ø 42.2 mm (1.66 inch) with multiple hole/316L ⁽⁹⁾⁽¹⁹⁾⁽²⁰⁾ | K | |
| Probe exchangeable cable ø 4 mm (0.16 inch) with gravity weight/Alloy C22 (2.4602) ⁽⁹⁾ | L | |



Level measurement

Continuous level measurement
Guided wave radar transmitters

SITRANS LG series

Selection and ordering data

Article No.

Article No.

| SITRANS LG250 Guided radar level transmitter | 7ML5881- | Ord. code |
|---|------------|-----------|
| Continuous, contact, 75 m (246 ft) range. Monitors level and interface in liquids. | | |
| Probe exchangeable cable ø 4 mm (0.16 inch) with centre weight/Alloy C22 (2.4602) ⁹⁾ | M | |
| Probe exchangeable rod ø 8 mm (0.31 inch) /Alloy C22 (2.4602) ⁹⁾ | N | |
| Probe exchangeable rod ø 12 mm (0.47 inch)/ Alloy C22 (2.4602) ⁹⁾ | P | |
| Probe coax version ø 21.3 mm (0.84 inch) with multiple hole/Alloy C22 (2.4602) ⁹⁾ | Q | |
| Probe coax version ø 42.2 mm (1.66 inch) with multiple hole/Alloy C22 (2.4602) ⁹⁾ | R | |
| Probe exchangeable rod ø 8 mm (0.31 inch)/ Duplex (1.4462) ⁹⁾ | S | |
| Exchangeable rod ø 12 mm (0.47 inch)/ Alloy C22 and 400 (2.4360) ⁹⁾ | T | |
| Exchangeable coated cable ø 4 mm with uncoated centering weight/PFA and 316 ²⁾¹⁾²⁴⁾³⁰⁾³⁵⁾³⁶⁾ | U | |
| Process fitting/Material | | |
| Thread G 3/4" (DIN 3852-A) PN 6/316L | 0 0 | |
| Thread 3/4" NPT (ASME B1.20.1) PN 6/316L | 0 1 | |
| Thread G 3/4" (DIN 3852-A) PN 40/316L | 0 2 | |
| Thread 3/4" NPT (ASME B1.20.1) PN 40/316L | 0 3 | |
| Thread G 3/4" (DIN 3852-A) PN 100 / 316L ²²⁾ | 0 4 | |
| Thread 3/4" NPT (ASME B1.20.1) PN 100/316L ²²⁾ | 0 5 | |
| Thread G 1" (DIN 3852-A) PN 40/316L | 0 6 | |
| Thread 1" NPT (ASME B1.20.1) PN 40/316L | 0 7 | |
| Thread G 1" (DIN 3852-A) PN 100/316L ²²⁾ | 0 8 | |
| Thread 1" NPT (ASME B1.20.1) PN 100/316L ²²⁾ | 1 0 | |
| Thread G 1 1/2" (DIN 3852-A) PN 40/316L | 1 1 | |
| Thread 1 1/2" NPT (ASME B1.20.1) PN 40/316L | 1 2 | |
| Thread G 1 1/2" (DIN 3852-A) PN 100/316L ²²⁾ | 1 3 | |
| Thread 1 1/2" NPT (ASME B1.20.1) PN 100/316L ²²⁾ | 1 4 | |
| Thread 2 NPT PN 40, ASME B1.20.1/316L ²³⁾²⁴⁾ | 1 5 | |
| Flange DN 25 PN 40 Form C, DIN 2501/316L | 2 0 | |
| Flange DN 25 PN 40 Form F, DIN 2501/316L | 2 1 | |
| Flange DN 40 PN 40 Form C, DIN 2501/316L | 2 2 | |
| Flange DN 50 PN 40 Form C, DIN 2501/316L | 2 3 | |
| Flange DN 50 PN 40 Form V13, DIN 2513/316L | 2 4 | |
| Flange DN 80 PN 40 Form C, DIN 2501/316L | 2 5 | |
| Flange DN 80 PN 40 Form V13, DIN 2501/316L | 2 6 | |
| Flange DN 100 PN 16 Form C, DIN 2501/316L | 2 7 | |
| Flange DN 100 PN 16 Form V13, DIN 2501/316L | 2 8 | |
| Flange DN 100 PN 40 Form C, DIN 2501 /316L | 3 0 | |
| Flange DN 100 PN 40 Form V13, DIN 2513/316L | 3 1 | |
| Flange DN 150 PN 16 Form C, DIN 2501/316L | 3 2 | |
| Flange DN 50 PN 40 EN 1092-1 Form B1/316L | 3 3 | |
| Flange DN 80 PN 40 EN 1092-1 Form B1/316L | 3 4 | |
| Flange 1" 150 lb RF, ASME B16.5/316L | 3 5 | |
| Flange 1 1/2" 150 lb RF, ASME B16.5/316L | 3 6 | |
| Flange 2" 150 lb RF, ASME B16.5/316L | 3 7 | |
| Flange 2" 300 lb RF, ASME B16.5/316L | 3 8 | |
| Flange 3" 150 lb RF, ASME B16.5/316L | 4 0 | |
| Flange 3" 300 lb RF, ASME B16.5/316L | 4 1 | |
| Flange 4" 150 lb RF, ASME B16.5/316L | 4 2 | |
| Flange 4" 300 lb RF, ASME B16.5/316L | 4 3 | |
| Flange 6" 150 lb RF, ASME B16.5/316L | 4 4 | |
| Flange 6" 300 lb RF, ASME B16.5/316L | 4 5 | |

| SITRANS LG250 Guided radar level transmitter | 7ML5881- | Ord. code |
|--|------------|-----------|
| Continuous, contact, 75 m (246 ft) range. Monitors level and interface in liquids. | | |
| Thread G 3/4" PN 40, DIN3852-A/ Alloy C22 (2.4602) ³⁷⁾ | 4 6 | |
| Thread G 1" PN 40, DIN 3852-A/ Alloy C22 (2.4602) ³⁷⁾ | 4 7 | |
| Thread G 1 1/2" PN 40, DIN 3852-A/ Alloy C22 (2.4602) | 4 8 | |
| Thread 1 1/2" NPT PN 40, ASME B1.20.1/Alloy C22 (2.4602) | 5 0 | |
| Flange DN 50 PN 40 Form C, DIN 2501/ 316L with Alloy C22 (2.4602) coating | 5 1 | |
| Flange DN 50 PN 40 Form B1, EN 1092-1/ 316L with Alloy C22 (2.4602) coating | 5 2 | |
| Flange DN 80 PN 40 Form B1, EN 1092-1/ 316L with Alloy C22 (2.4602) coating | 5 3 | |
| Flange DN 100 PN 40 Form B1, EN 1092-1/ 316L with Alloy C22 (2.4602) coating | 5 4 | |
| Flange DN 150 PN 16 Form B1, EN 1092-1/ 316L with Alloy C22 (2.4602) coating | 5 5 | |
| Flange DN 200 PN 16 Form B1, EN 1092-1/ 316L with Alloy C22 (2.4602) coating | 5 6 | |
| Flange 2" 150 lb RF, ASME B16.5/316L with Alloy C22 (2.4602) coating | 5 7 | |
| Flange 2" 300 lb RF, ASME B16.5/316L with Alloy C22 (2.4602) coating | 5 8 | |
| Flange 3" 150 lb RF, ASME B16.5/316L with Alloy C22 (2.4602) coating | 6 0 | |
| Flange 4" 150 lb RF, ASME B16.5/316L with Alloy C22 (2.4602) coating | 6 1 | |
| Flange 4" 300 lb RF, ASME B16.5/316L with Alloy C22 (2.4602) coating | 6 2 | |
| Flange 6" 150 lb RF, ASME B16.5/316L with Alloy C22 (2.4602) coating | 6 3 | |
| Flange 6" 300 lb RF, ASME B16.5/316L with Alloy C22 (2.4602) coating | 6 4 | |
| Thread G 3/4" (DIN 3852-A) PN 40/Duplex 1.4462 | 6 5 | |
| Flange DN 80 PN 40 Form F, DIN 2501/Duplex (1.4462) | 6 6 | |
| Flange DN 50 PN 40 Form B1, EN 1092-1/ Duplex (1.4462) | 6 7 | |
| Flange 1" 150 lb RF, ASME B16.5/Duplex (1.4462) | 6 8 | |
| Flange 1 1/2" 150 lb RF, ASME B16.5/Duplex (1.4462) | 7 0 | |
| Flange 2" 150 lb RF, ASME B16.5/Duplex (1.4462) | 7 1 | |
| Flange 2" 300 lb RF, ASME B16.5/Duplex (1.4462) | 7 2 | |
| Flange 2" 600 lb RF, ASME B16.5/Duplex (1.4462) | 7 3 | |
| Flange 3" 150 lb RF, ASME B16.5/Duplex (1.4462) | 7 4 | |
| Flange 3" 300 lb RF, ASME B16.5/Duplex (1.4462) | 7 5 | |
| Flange 4" 150 lb RF, ASME B16.5/Duplex (1.4462) | 7 6 | |
| Flange 4" 150 lb FF, ASME B16.5/Duplex (1.4462) | 7 7 | |
| Flange 4" 300 lb RF, ASME B16.5/Duplex (1.4462) | 7 8 | |
| Flange 4" 600 lb RF, ASME B16.5/Duplex (1.4462) | 8 0 | |
| Thread 1 1/2" NPT PN 40, ASME B1.20.1/Alloy 400 (2.4360) | 8 1 | |
| Flange 2" 150 lb RF, ASME B16.5/Alloy 400 (2.4360) | 8 2 | |
| Flange 2" 300 lb RF, ASME B16.5/Alloy 400 (2.4360) solid | 8 3 | |
| Flange 3" 150 lb RF, ASME B16.5/Alloy 400 (2.4360) | 8 4 | |
| Flange 3" 300 lb RF, ASME B16.5/Alloy 400 (2.4360) | 8 5 | |

Level measurement

Continuous level measurement

Guided wave radar transmitters

SITRANS LG series

| Selection and ordering data | Article No. | Article No. |
|---|-----------------|-----------------|
| SITRANS LG250 Guided radar level transmitter | 7ML5881- | 7ML5881- |
| Continuous, contact, 75 m (246 ft) range. Monitors level and interface in liquids. | | |
| Flange 3" 300 lb RJF, ASME B16.5/Alloy 400 (2.4360) | 8 6 | B |
| Flange 4" 150 lb RF, ASME B16.5/Alloy 400 (2.4360) | 8 7 | C |
| Flange 4" 300 lb RF, ASME B16.5/Alloy 400 (2.4360) | 8 8 | D |
| Flange DN 25 PN 40 Form C, DIN 2501/ Alloy C22 (2.4602) solid ³⁷⁾ | 9 0 | E |
| Flange DN 25 PN 40 Form B1, EN 1092-1/ Alloy C22 (2.4602) solid ³⁷⁾ | 9 0 | F |
| Flange DN 80 PN 40 Form B1, EN 1092-1/ Alloy C22 (2.4602) solid | 9 0 | G |
| Flange 1" 150 lb RF, ASME B16.5/Alloy C22 (2.4602) solid ³⁷⁾ | 9 0 | H |
| Flange 1 1/2" 150 lb RF, ASME B16.5/ Alloy C22 (2.4602) solid ³⁷⁾ | 9 0 | J |
| Flange 1 1/2" 300 lb RF, ASME B16.5/ Alloy C22 (2.4602) solid ³⁷⁾ | 9 0 | K |
| Flange 2" 150 lb RF, ASME B16.5/ Alloy C22 (2.4602) solid | 9 0 | L |
| Flange 2" 300 lb RF, ASME B16.5/ Alloy C22 (2.4602) solid | 9 0 | M |
| Flange 2" 600 lb RF, ASME B16.5/ Alloy C22 (2.4602) solid | 9 0 | N |
| Flange 2" 1 500 lb RJF, ASME B16.5/ Alloy C22 (2.4602) solid | 9 0 | O |
| Flange 3" 150 lb RF, ASME B16.5/ Alloy C22 (2.4602) solid | 9 0 | P |
| Flange 3" 300 lb RF, ASME B16.5/ Alloy C22 (2.4602) solid | 9 0 | Q |
| Flange 3" 300 lb RF, ASME B16.5/316L with Alloy C22 (2.4602) coating | 9 0 | R |
| Flange 4" 150 lb RF, ASME B16.5/ Alloy C22 (2.4602) solid | 9 0 | S |
| Flange 4" 150 lb FF, ASME B16.5/ Alloy C22 (2.4602) solid | 9 0 | T |
| Flange 4" 300 lb RF, ASME B16.5/ Alloy C22 (2.4602) solid | 9 0 | U |
| Flange 4" 300 lb LT, ASME B16.5/ Alloy C22 (2.4602) solid | 9 0 | |
| Flange 4" 600 lb RJF, ASME B16.5/ Alloy C22 (2.4602) solid | 9 0 | A |
| Flange 6" 150 lb RF, ASME B16.5/ Alloy C22 (2.4602) solid | 9 0 | B |
| Flange 2 1/2" 600 lb RF, Masoneilan/ Alloy C22 (2.4602) solid | 9 0 | G |
| Flange 2" 600 lb RF, ASME B16.5/316/316 L ²⁴⁾ | 9 0 | H |
| Flange 3" 600 lb RF, ASME B16.5/316/316 L ²⁴⁾²⁵⁾ | 9 0 | C |
| Flange 4" 600 lb RF, ASME B16.5/316/316 L ³¹⁾ | 9 0 | D |
| Thread R1½ PN40, EN 10226-1/316L ³⁸⁾ | | E |
| Flange NPS 2" Class 1500 RF, ASME B16.5 / 316/316L ³⁹⁾ | 9 0 | F |
| Electronics | | L |
| Two-wire 4 ... 20 mA/HART | 0 | M |
| Four-wire Modbus ²⁾⁸⁾¹¹⁾ | 1 | N |
| Two-wire 4 ... 20 mA/HART with SIL qualification ⁹⁾¹⁰⁾ | 2 | P |
| Four-wire 4 ... 20 mA/HART; 90 ... 253 V AC; 50/60Hz ²⁾⁸⁾¹¹⁾³⁴⁾ | 3 | Q |
| Four-wire 4 ... 20 mA/HART; 9.6 ... 48 V DC; 20 ... 42 V AC ²⁾⁸⁾¹¹⁾³⁴⁾ | 4 | R |
| PROFIBUS PA ⁵⁾⁸⁾ | 5 | S |
| FOUNDATION Fieldbus ⁵⁾⁸⁾ | 6 | |
| Seal/Second line of defense/ Process temperature | | |
| FKM (SHS FPM 70C3 GLT)/without glass seal/-40 ... +80 °C (-40 ... +176 °F) | A | |
| SITRANS LG250 Guided radar level transmitter | | |
| Continuous, contact, 75 m (246 ft) range. Monitors level and interface in liquids. | | |
| FKM (SHS FPM 70C3 GLT)/without glass seal/-40 ... +150 °C (-40 ... +302 °F) | | B |
| FKM (SHS FPM 70C3 GLT)/with glass seal/-40 ... +150 °C (-40 ... +302 °F) ²⁶⁾ | | C |
| FFKM (Kalrez 6375)/without/-20 ... 150 °C (-4 ... +302 °F) | | D |
| FFKM (Kalrez 6375)/with/-20 ... +150 °C (-4 ... +302 °F) ³⁾ | | E |
| FFKM (Kalrez 6375)/with glass seal/-20 ... +200 °C (-4 ... +392 °F) ²⁶⁾ | | F |
| EPDM (A+P 75.5/KW75F)/without glass seal/-40 ... +80 °C (-40 ... +176 °F) | | G |
| EPDM (A+P 75.5/KW75F)/without glass seal/-40 ... +150 °C (-40 ... +302 °F) ²⁶⁾ | | H |
| EPDM (A+P 75.5/KW75F)/with glass seal/-40 ... +150 °C (-40 ... +302 °F) ²⁶⁾ | | J |
| Silicone FEP coated (A+P FEP-O-SEAL)/ without glass seal/-40 ... +80 °C (-40 ... +176 °F) | | K |
| Silicone FEP coated (A+P FEP-O-SEAL)/ without glass seal/-40 ... +150 °C (-40 ... +302 °F) | | L |
| Silicone FEP coated (A+P FEP-O-SEAL)/ with glass seal/-40 ... +150 °C (-40 ... +302 °F) ²⁶⁾ | | M |
| With borosilicate glass lead through for volatile substances, e.g. ammonia/with glass seal/-60 ... +150 °C (-76 ... +302 °F) ²⁶⁾ | | N |
| FFKM (Kalrez 6375)/without glass seal/-20 ... +200 °C (-4 ... +392 °F) | | P |
| FKM (SHS FPM 70C3 GLT)/with glass seal/-40 ... 80 °C (-40 ... +176 °F) ²⁶⁾ | | Q |
| FFKM (Kalrez 6375)/without/-10 ... +150 °C | | R |
| FFKM (Kalrez 6375)/without/-10 ... +200 °C | | S |
| FFKM (Kalrez 6375)/with/-10 ... +150 °C | | T |
| FFKM (Kalrez 6375)/with/-10 ... +200 °C | | U |
| Housing/Protection/Cable | | |
| Note: for installation of remote display, 7ML5840, with LG two chamber housing options, contact PVC | | |
| Plastic IP66/IP67 M20 x 1.5/blind stopper ¹¹⁾¹⁵⁾ | | A |
| Plastic IP66/IP67 1/2" NPT/blind stopper ⁸⁾¹¹⁾ | | B |
| Plastic 2-chamber/IP66/IP67/M20 x 1.5/ blind stopper | | G |
| Plastic 2-chamber/IP66/IP67 /1/2" NPT/ blind stopper | | H |
| Aluminum/IP66/IP68 (0.2 bar) M20 x 1.5/ Blind stopper ⁸⁾¹¹⁾ | | C |
| Aluminum/IP66/IP68 (0.2 bar) 1/2" NPT/ Blind stopper ⁸⁾¹¹⁾ | | D |
| Aluminum double chamber/IP66/IP68 (0.2 bar) M20 x 1.5 / Blind stopper | | E |
| Aluminum double chamber/IP66/IP68 (0.2 bar) 1/2" NPT/Blind stopper | | F |
| Stainless Steel (precision casting) 316L/ IP66/IP68 (0.2 bar) M20 x 1.5/ Blind stopper ⁹⁾¹¹⁾ | | L |
| Stainless Steel (precision casting) 316L/ IP66/IP68 (0.2 bar) 1/2" NPT/ Blind stopper ⁸⁾¹¹⁾ | | M |
| Stainless Steel (electropolished) 316L/IP66/IP68 (0.2 bar) M20 x 1.5/ Blind stopper ⁸⁾¹¹⁾ | | N |
| Stainless Steel (electropolished) 316L/IP66/IP68 (0.2 bar) 1/2" NPT/ Blind stopper ⁸⁾¹¹⁾ | | P |
| Stainless Steel double chamber/IP66/IP68 (0.2 bar) M20 x 1.5/Blind stopper | | Q |
| Stainless Steel double chamber/IP66/IP68 (0.2 bar) 1/2" NPT/Blind stopper | | R |
| Aluminum/IP66/IP68 (0.2 bar) M20 x 1.5/ Cable gland stainless steel ⁸⁾¹¹⁾ | | S |

Level measurement

Continuous level measurement
Guided wave radar transmitters

SITRANS LG series

Selection and ordering data

Article No.

Article No.

| SITRANS LG250 Guided radar level transmitter | 7ML5881- | Ord. code |
|--|----------|-----------|
| Continuous, contact, 75 m (246 ft) range. Monitors level and interface in liquids. | | |
| Aluminum double chamber/IP66/IP68 (0.2 bar) M20 x 1.5/Cable gland stainless steel | T | |
| Stainless Steel (precision casting) 316L/IP66/IP68 (0.2 bar) M20 x 1.5/Cable gland stainless steel ¹¹⁾²⁸⁾ | U | |
| Stainless Steel (electropolished) 316L/IP66/IP68 (0.2 bar) M20 x 1.5/Cable gland stainless steel ¹¹⁾²⁸⁾ | V | |
| Stainless steel single chamber (precision casting)/IP66/IP68 (0.2 bar) M20 x 1.5/Cable gland brass nickel-plated | W | |
| Aluminum single chamber/IP66/IP68 (0.2 bar) M20 x 1.5/Cable gland brass nickel-plated | X | |
| Stainless steel single chamber (precision casting)/IP66/ IP68 (0.2 bar) M20 x 1.5/Cable gland brass nickel-plated | Y | |
| Stainless steel double chamber / IP66/ IP68 (0.2 bar) M20 x 1.5 / Cable gland brass nickel-plated | J | |
| Aluminum single chamber/IP66/IP68 (0.2 bar) with M20 x 1.5/Plug connector Harting HAN 7D (straight) | Z | Q 1 A |
| Aluminum single chamber/IP66/IP68 (0.2 bar) with M20 x 1.5/Special HARTING plug (bent) according to Tier One (ZB7555) | Z | Q 1 B |
| Remote stainless steel single chamber housing, electropolished/IP66/IP67 with cable outlet IP68 (electronics separated by cable); M20 x 1.5/blind plug ¹¹⁾²⁷⁾ | Z | Q 2 A |
| Remote plastic single chamber housing /IP66/IP67 with cable outlet IP68 (electronics separated by cable); M20 x 1.5/blind plug ¹¹⁾²⁷⁾ | Z | Q 2 B |
| Lengths | | |
| <u>Rod ø 8 mm/316L</u> | | |
| 300 ... 1 000 mm (11.81 ... 39.37 inch) ²⁹⁾ | 0 | |
| 1 001 ... 2 000 mm (39.41 ... 78.74 inch) ²⁹⁾ | 1 | |
| 2 001 ... 3 000 mm (78.78 ... 118.11 inch) ²⁹⁾ | 2 | |
| 3 001 ... 4 000 mm (118.15 ... 157.48 inch) ²⁹⁾ | 3 | |
| 4 001 ... 5 000 mm (157.52 ... 196.85 inch) ²⁹⁾ | 4 | |
| 5 001 ... 6 000 mm (196.89 ... 236.22 inch) ²⁹⁾ | 5 | |
| <u>Rod ø 8 mm/Duplex</u> | | |
| 300 ... 1 000 mm (11.81 ... 39.37 inch) ²⁹⁾ | 9 | R 1 A |
| 1 001 ... 2 000 mm (39.41 ... 78.74 inch) ²⁹⁾ | 9 | R 1 B |
| 2 001 ... 3 000 mm (78.78 ... 118.11 inch) ²⁹⁾ | 9 | R 1 C |
| 3 001 ... 4 000 mm (118.15 ... 157.48 inch) ²⁹⁾ | 9 | R 1 D |
| 4 001 ... 5 000 mm (157.52 ... 196.85 inch) ²⁹⁾ | 9 | R 1 E |
| 5 001 ... 6 000 mm (196.89 ... 236.22 inch) ²⁹⁾ | 9 | R 1 F |
| <u>Rod ø 8 mm or ø 12 mm /Alloy C22 and 400</u> | | |
| 300 ... 1 000 mm (11.81 ... 39.37 inch) ²⁹⁾ | 9 | R 1 J |
| 1 001 ... 2 000 mm (39.41 ... 78.74 inch) ²⁹⁾ | 9 | R 1 K |
| 2 001 ... 3 000 mm (78.78 ... 118.11 inch) ²⁹⁾ | 9 | R 1 L |
| 3 001 ... 4 000 mm (118.15 ... 157.48 inch) ²⁹⁾ | 9 | R 1 M |
| 4 001 ... 5 000 mm (157.52 ... 196.85 inch) ²⁹⁾ | 9 | R 1 N |
| 5 001 ... 6 000 mm (196.89 ... 236.22 inch) ²⁹⁾ | 9 | R 1 P |
| <u>Rod ø 12 mm/316L</u> | | |
| 300 ... 1 000 mm (11.81 ... 39.37 inch) ²⁹⁾ | 9 | R 2 A |
| 1 001 ... 2 000 mm (39.41 ... 78.74 inch) ²⁹⁾ | 9 | R 2 B |
| 2 001 ... 3 000 mm (78.78 ... 118.11 inch) ²⁹⁾ | 9 | R 2 C |
| 3 001 ... 4 000 mm (118.15 ... 157.48 inch) ²⁹⁾ | 9 | R 2 D |
| <u>Cable lengths ø 2 or 4 mm/316L</u> | | |
| 501 ... 1 000 mm (19.72 ... 39.37 inch) | 9 | R 2 E |
| 1 000 ... 5 000 mm (39.37 ... 196.85 inch) | 9 | R 2 F |
| 5 001 ... 10 000 mm (196.89 ... 393.70 inch) | 9 | R 2 G |
| 10 001 ... 15 000 mm (393.74 ... 590.55 inch) | 9 | R 2 H |
| 15 001 ... 20 000 mm (590.59 ... 787.40 inch) | 9 | R 2 J |
| 20 001 ... 25 000 mm (787.44 ... 984.25 inch) | 9 | R 2 K |

| SITRANS LG250 Guided radar level transmitter | 7ML5881- | Ord. code |
|--|----------|-----------|
| Continuous, contact, 75 m (246 ft) range. Monitors level and interface in liquids. | | |
| 25 001 ... 30 000 mm (984.29 ... 1 181.10 inch) | 9 | R 2 L |
| 30 001 ... 35 000 mm (1 181.14 ... 1 377.95 inch) | 9 | R 2 M |
| 35 001 ... 40 000 mm (1 377.99 ... 1 574.80 inch) | 9 | R 2 N |
| 40 001 ... 45 000 mm (1 574.84 ... 1 771.65 inch) | 9 | R 2 P |
| 45 001 ... 50 000 mm (1 771.69 ... 1 968.50 inch) | 9 | R 2 Q |
| 50 001 ... 55 000 mm (1 968.54 ... 2 165.35 inch) | 9 | R 2 R |
| 55 001 ... 60 000 mm (2 165.39 ... 2 362.20 inch) | 9 | R 2 S |
| 60 001 ... 65 000 mm (2 362.24 ... 2 559.06 inch) | 9 | R 2 T |
| 65 001 ... 70 000 mm (2 559.09 ... 2 755.91 inch) | 9 | R 2 U |
| 70 001 ... 75 000 mm (2 755.94 ... 2 952.76 inch) | 9 | R 2 V |
| <u>Cable Lengths ø 2 mm or ø 4 mm/Alloy C22</u> | | |
| 501 ... 1 000 mm (19.72 ... 39.37 inch) | 9 | R 4 A |
| 1 001 ... 5 000 mm (39.41 ... 196.85 inch) | 9 | R 4 B |
| 5 001 ... 10 000 mm (196.89 ... 393.70 inch) | 9 | R 4 C |
| 10 001 ... 15 000 mm (393.74 ... 590.55 inch) | 9 | R 4 D |
| 15 001 ... 20 000 mm (590.59 ... 787.40 inch) | 9 | R 4 E |
| 20 001 ... 25 000 mm (787.44 ... 984.25 inch) | 9 | R 4 F |
| 25 001 ... 30 000 mm (984.29 ... 1 181.10 inch) | 9 | R 4 G |
| 30 001 ... 35 000 mm (1 181.14 ... 1 377.95 inch) | 9 | R 4 H |
| 35 001 ... 40 000 mm (1 377.99 ... 1 574.80 inch) | 9 | R 4 J |
| 40 001 ... 45 000 mm (1 574.84 ... 1 771.65 inch) | 9 | R 4 K |
| 45 001 ... 50 000 mm (1 771.69 ... 1 968.50 inch) | 9 | R 4 L |
| 50 001 ... 55 000 mm (1 968.54 ... 2 165.35 inch) | 9 | R 4 M |
| 55 001 ... 60 000 mm (2 165.39 ... 2 362.20 inch) | 9 | R 4 N |
| 60 001 ... 65 000 mm (2 362.24 ... 2 559.06 inch) | 9 | R 4 P |
| 65 001 ... 70 000 mm (2 559.09 ... 2 755.91 inch) | 9 | R 4 Q |
| 70 001 ... 75 000 mm (2 755.94 ... 2 952.76 inch) | 9 | R 4 R |
| <u>Coax ø 21.3 mm/316L</u> | | |
| 300 ... 1 000 mm (11.81 ... 39.37 inch) ²⁹⁾ | 9 | R 3 A |
| 1 001 ... 2 000 mm (39.41 ... 78.74 inch) ²⁹⁾ | 9 | R 3 B |
| 2 001 ... 3 000 mm (78.78 ... 118.11 inch) ²⁹⁾ | 9 | R 3 C |
| 3 001 ... 4 000 mm (118.15 ... 157.48 inch) ²⁹⁾ | 9 | R 3 D |
| 4 001 ... 5 000 mm (157.52 ... 196.85 inch) ²⁹⁾ | 9 | R 3 E |
| 5 001 ... 6 000 mm (196.89 ... 236.22 inch) ²⁹⁾ | 9 | R 3 F |
| <u>Coax ø 21.3 mm/Alloy C22</u> | | |
| 300 ... 1 000 mm (11.81 ... 39.37 inch) ²⁹⁾ | 9 | R 5 A |
| 1 001 ... 2 000 mm (39.41 ... 78.74 inch) ²⁹⁾ | 9 | R 5 B |
| 2 001 ... 3 000 mm (78.78 ... 118.11 inch) ²⁹⁾ | 9 | R 5 C |
| 3 001 ... 4 000 mm (118.15 ... 157.48 inch) ²⁹⁾ | 9 | R 5 D |
| 4 001 ... 5 000 mm (157.52 ... 196.85 inch) ²⁹⁾ | 9 | R 5 E |
| 5 001 ... 6 000 mm (196.89 ... 236.22 inch) ²⁹⁾ | 9 | R 5 F |
| <u>Coax ø 42.2 mm/316L</u> | | |
| 300 ... 1 000 mm (11.81 ... 39.37 inch) ²⁹⁾ | 9 | R 3 G |
| 1 001 ... 2 000 mm (39.41 ... 78.74 inch) ²⁹⁾ | 9 | R 3 H |
| 2 001 ... 3 000 mm (78.78 ... 118.11 inch) ²⁹⁾ | 9 | R 3 J |
| 3 001 ... 4 000 mm (118.15 ... 157.48 inch) ²⁹⁾ | 9 | R 3 K |
| 4 001 ... 5 000 mm (157.52 ... 196.85 inch) ²⁹⁾ | 9 | R 3 L |



| Selection and ordering data | Article No. | Order code |
|---|-----------------|------------|
| SITRANS LG250 Guided radar level transmitter | 7ML5881- | |
| Continuous, contact, 75 m (246 ft) range. Monitors level and interface in liquids. | | |
| 5 001 ... 6 000 mm (196.89 ... 236.22 inch) ²⁹⁾ | 9 R 3 M | L07 |
| Coax ø 42.2 mm/Alloy C22 | | |
| 300 ... 1 000 mm (11.81 ... 39.37 inch) ²⁹⁾ | 9 R 5 G | L08 |
| 1 001 ... 2 000 mm (39.41 ... 78.74 inch) ²⁹⁾ | 9 R 5 H | L09 |
| 2 001 ... 3 000 mm (78.78 ... 118.11 inch) ²⁹⁾ | 9 R 5 J | L10 |
| 3 001 ... 4 000 mm (118.15 ... 157.48 inch) ²⁹⁾ | 9 R 5 K | |
| 4 001 ... 5 000 mm (157.52 ... 196.85 inch) ²⁹⁾ | 9 R 5 L | |
| 5 001 ... 6 000 mm (196.89 ... 236.22 inch) ²⁹⁾ | 9 R 5 M | |
| Cable lengths ø 4 mm PFA | | |
| 300 ... 1 000 mm (12 ... 39.37 inch) | 9 R 6 A | |
| 1 001 ... 2 000 mm (39.41 ... 78.74 inch) | 9 R 6 B | |
| 2 001 ... 5 000 mm (78.77 ... 196.85 inch) | 9 R 6 C | |
| 5 001 ... 10 000 mm (196.89 ... 393.70 inch) | 9 R 6 D | |
| 10 001 ... 15 000 mm (393.74 ... 590.55 inch) | 9 R 6 E | |
| 15 001 ... 20 000 mm (590.59 ... 787.40 inch) | 9 R 6 F | |
| 20 001 ... 25 000 mm (787.44 ... 984.25 inch) | 9 R 6 G | |
| 25 001 ... 32 000 mm (984.29 ... 1 259.84 inch) | 9 R 6 H | |
| Further designs (mandatory) | Order code | |
| Please add "-Z" to Article No. and specify Order code(s). | | |
| Supplementary electronics | | |
| Without | A00 | |
| Additional current output 4 ... 20 mA ¹¹⁾ | A01 | |
| Dimensions centering weight (diameter/height) | | |
| Without | B00 | |
| ø 40/30 mm | B01 | |
| ø 45/30 mm (for 2 inch tubes) | B02 | |
| ø 75/30 mm (for 3 inch tubes) | B03 | |
| ø 95/30 mm (for 4 inch tubes) | B04 | |
| ø 40 mm/30 mm | B05 | |
| ø 1.57/1.18 inch (for 2 inch Schedule 160) | B06 | |
| ø 45 mm/30 mm (for 2 inch tubes) | B07 | |
| ø 1.77/1.18 inch (for 2 inch Schedule 40/80) | B08 | |
| ø 75 mm/30 mm (for 3 inch tubes) | | |
| ø 2.95/1.18 inch (for 3 inch Schedule 10/40) | | |
| ø 95 mm/30 mm (for 4 inch tubes) | | |
| ø 3.74/1.18 inch (for 4 inch Schedule 80) | | |
| Rod mounted | | |
| Without Rod, applicable for coax or cable probe types only | C00 | |
| Mounted | C01 | |
| Not mounted | C02 | |
| Indicating/adjustment module | | |
| Without | E00 | |
| Mounted | E01 | |
| Laterally mounted | E02 | |
| Language of display | | |
| German | L00 | |
| English | L01 | |
| French | L02 | |
| Dutch | L03 | |
| Italian | L04 | |
| Spanish | L05 | |
| Portuguese | L06 | |
| Russian | | L07 |
| Chinese | | L08 |
| Japanese | | L09 |
| No language pre-set | | L10 |
| Operating instructions | | |
| German | | M00 |
| English | | M01 |
| French | | M02 |
| Spanish | | M03 |
| Further designs (optional) | | |
| Please add "-Z" to Article No. and specify Order code(s). | | |
| Enter the total insertion length in plain text description | | Y01 |
| Enter the total length of rigid part (cable version only) range from 100 ... 1 000 mm | | Y02 |
| Remote electronic cable lengths: 2 m (6.6 ft). Only available with Housing options Q2A and Q2B | | Y10 |
| Remote electronic cable lengths: 5 m (16.4 ft). Only available with Housing options Q2A and Q2B | | Y11 |
| Remote electronic cable lengths: 10 m (32.8 ft). Only available with Housing options Q2A and Q2B | | Y12 |
| Identification Label (measurement loop) stainless steel, 40 characters max, add in plain text. To add more than one line use a coma "," for line break. | | Y17 |
| Identification Label (measurement loop) foil, 40 characters max, add in plain text. To add more than one line use a coma "," for line break. | | Y18 |
| Material Inspection certificate 3.1 of EN 10204 | | C05 |
| 3.1-Inspection Certificate for instrument (EN 10204) ³⁰⁾ | | C12 |
| Inspection certificate 3.1 (EN 10204, NACE MR 0175) - material ³⁰⁾³¹⁾ Note: 316L probes include NACE MR 0175 and MR 0103, non 316L probes include MR 0175 only and plated flange designs are not available with NACE certificate. | | D07 |
| 3.1-Inspection Certificate for instrument with test data (EN 10204) ³⁰⁾ | | C25 |
| 2.2-Factory certificate for material (EN 10204) ³⁰⁾ | | C15 |
| Quality and test plan ³⁰⁾ | | C26 |
| Dye penetration test, results confirmed via a 3.1 certificate/instrument (EN10204) ³⁰⁾ | | C13 |
| X-ray test + 3.1 certificate/instrument ³⁰⁾ | | C14 |
| Positive material identification test + 3.1 certificate/instrument ³⁰⁾ | | C16 |
| Roughness test + 3.1 certificate/instrument ³⁰⁾ | | C18 |
| Pressure test + 3.1 certificate/instrument ³⁰⁾ | | C31 |
| Helium leak test + 3.1 certificate/instrument ³⁰⁾ | | C32 |
| Pressure test according to Norsok + 3.1 certificate/instrument ³⁰⁾ | | C61 |
| 5 point calibration certificate (min. length 500 mm) ³⁰⁾ | | C62 |
| Pressure test (acc. to ASME B31.1), incl. 3.1 Inspection certificate ³⁰⁾ | | C63 |
| Certificate suitable for tropical regions with, all attachment parts of metal (2.1 factory certificate) | | C65 |

Level measurement

Continuous level measurement Guided wave radar transmitters

SITRANS LG series

Selection and ordering data

Article No.

Operating Instructions

All literature is available to download for free, in a range of languages, at

<http://www.siemens.com/processinstrumentation/documentation>

Accessories

| | Article No. |
|---|--------------------------|
| SITRANS LG series/SITRANS RD150 sensor display module | A5E34143449 |
| SITRANS LG, two-wire 4 ... 20 mA/HART electronic | A5E35637821 |
| SITRANS LG, USB communicator | A5E35192015 |
| SITRANS LG, Mounting eye M8 x 20 | A5E36653574 |
| SITRANS LG, Mounting eye M12 x 20 | PBD:51041448 |
| SITRANS LG, Mounting spring | PBD:51041449 |
| Siemens Intrinsically Safe Barrier (DC powered), ATEX II 1 G EEx ia | 7NG4124-0AA00 |
| SITRANS RD100, loop powered display - see Chapter 7 | 7ML5741-.....- |
| SITRANS RD150, remote digital display for 4 ... 20 mA and HART devices - see Chapter 7 | 7ML5742-.....-... |
| SITRANS RD200, universal input display with Modbus conversion - see Chapter 7 | 7ML5740-.....-.. |
| SITRANS RD300, dual line display with totalizer and linearization curve and Modbus conversion - see Chapter 7 | 7ML5744-.....-.. |
| For applicable back up point level switch - see point level measurement section | |

Note: some configuration options are not available.

For restriction information see the online PIA configuration tool.

Note: Please consult manual for further details.

- 1) Not available with Plastic and Stainless steel (electropolished) Housing/Protection/Cable options and certain glands.
- 2) Available only with Metallic, Double chamber Housing/Protection/Cable options and certain glands.
- 3) Not available with Remote or Stainless steel (electropolished) Housing/Protection/Cable options and certain glands.
- 4) Not available with Stainless steel (electropolished) Housing/Protection/Cable options and certain glands.
- 5) Not available with certain glands.
- 6) Not available with Version/Material option K, L, M, N, P, Q, R, S, T, and U.
- 7) Not available with Length options 3, 4, 5, R2C, and R2D.
- 8) Available only with Supplementary electronic option A00.
- 9) Not available with Seal/Second line of defense/Process temperature option N.
- 10) Not available with Housing/Protection/Cable option Q1B.
- 11) Not available with Indicating/adjustment module option E02.
- 12) Not available with Process fitting/Material options 00 and 01.
- 13) Available only with Electronic options 0 ... 4.
- 14) Available only with glass seal options.
- 15) Available only with Seal/Second line of defense/Process temperature options C, D, E, F, H, J, M, N, Q.
- 16) Not Available with Housing/Protection/Cable options W, X, Y, J, Q1A, and Q1B.
- 17) Not Available with Seal/Second line of defense/Process temperature option P.
- 18) Available only with Single chamber, Aluminum and Stainless steel (precision casting) Housing/Protection/Cable options.
- 19) Available only with Dimensions centering weight option B00.
- 20) Available only with Rod mounted option C00.
- 21) Not available with Dimensions centering weight option B00.
- 22) Available only with Seal/Second line of defense/Process temperature option N.
- 23) Not available with Version/Material options F, L, M, N, P, Q, R, S, and T.
- 24) Not available with Seal/Process temperature options A, G, K, N, and Q.
- 25) Available only with Version/Material options A ... K.
- 26) Not available with Remote Housing/Protection/Cable options.
- 27) Not available with some Seal/Process temperature options including glass.

28) Not available with Supplementary electronics options.

29) Not available with Y02.

30) Listed Certificates are not available with all configurations, please contact factory for more information.

31) Available only with 316L Probes. NACE is not available with coated, plated, or hygienic connections.

32) Available only with Housing/Protection/Cable options E, F, N, Q, R, T.

33) Available only with Housing/Protection/Cable options C, D, E, F, L, M, N, P, Q, R, S, T, U, V, Q2A, and Q2B.

34) Available only with Double chamber, Plastic and Metallic Housing/Protection/Cable options and certain glands.

35) Available only with Approvals options OA (CE only) and 1D.

36) Available only with ø 4 mm PFA Length options.

37) Not available with Probe version/Material option P.

38) Available only with Probe version/Material options G and H.

39) Available only with Probe version/Material options A ... E and H.

| Selection and ordering data | Article No. | Article No. | |
|---|--|--|--|
| SITRANS LG260 Guided radar level transmitter Continuous, contact, 60 m (197 ft) range. Monitors level in solids. ↗ Click on the Article No. for the online configuration in the PIA Life Cycle Portal. | 7ML5882- Ord. code | 7ML5882- Ord. code | |
| Approvals General purpose (CSA, FM, CE) ⁽⁶⁾ Shipping approval ⁽⁴⁾⁽⁵⁾⁽⁷⁾⁽⁸⁾⁽⁹⁾ Overfill protection (WHG; VLAREM) ⁽⁵⁾⁽⁸⁾ ATEX II 1G, 1/2G, 2G Ex ia IIC T6 ⁽⁵⁾⁽⁸⁾ ATEX II 1G, 1/2G, 2G Ex ia IIC + Overfill (WHG; VLAREM) ⁽⁵⁾⁽⁸⁾ ATEX II 1G, 1/2G, 2G Ex ia IIC T6 + shipping approval ⁽⁴⁾⁽⁵⁾⁽⁷⁾⁽⁸⁾⁽⁹⁾⁽¹⁰⁾ ATEX II 1G, 1/2G, 2G Ex ia IIC + II 1D, 1/2D, 1/3D, 2D IP66 ⁽¹⁾⁽⁵⁾⁽⁸⁾ ATEX II 1/2G, 2G Ex d ia IIC T6 ⁽²⁾⁽⁵⁾⁽⁸⁾⁽⁹⁾⁽¹⁰⁾ ATEX II 1/2G, 2G Ex d ia IIC + shipping approval ⁽²⁾⁽⁵⁾⁽⁷⁾⁽⁸⁾⁽⁹⁾⁽¹⁰⁾ ATEX II 1/2G, II 2G Ex db ia IIC T6 ... T1 Ga/Gb, Gb + II 1D, 1/2D, 1/3D, 2D Ext IIIC T* Da, Da/Db, Da/Dc, Db ⁽²⁾⁽⁵⁾⁽⁸⁾⁽⁹⁾⁽¹⁰⁾ ATEX II 1/2G, 2G Ex d IIC T6 ⁽⁸⁾⁽¹⁰⁾⁽¹¹⁾ ATEX II 1G, II 1/2G, II 2G Ex ia IIC T6...T1 Ga, Ga/Gb, Gb /IEC Ex ia IIC T6...T1 Ga, Ga/Gb, Gb ⁽⁸⁾ ATEX II 1/2G, 2G Ex d IIC + shipping approval ⁽¹⁾⁽⁷⁾⁽⁸⁾⁽⁹⁾⁽¹⁰⁾⁽¹¹⁾ ATEX II 1/2G, 2G Ex d IIC + II 1D, 1/2D, 1/3D, 2D IP66 ⁽¹⁾⁽⁸⁾⁽¹⁰⁾⁽¹¹⁾ ATEX II 1D, 1/2D, 2D IP6x T ⁽⁸⁾⁽¹¹⁾ IEC Ex ia IIC T6 ⁽⁵⁾⁽⁸⁾ IEC Ex ia IIC T6...T1 Ga, Ga/Gb, Gb + Ex t IIIC T ⁽⁸⁾⁽¹¹⁾ IEC Ex d ia IIC T6 ⁽²⁾⁽⁵⁾⁽⁸⁾⁽⁹⁾⁽¹⁰⁾ IEC Ex d ia IIC T6 + IEC IP6x T ⁽²⁾⁽⁵⁾⁽⁸⁾⁽⁹⁾⁽¹⁰⁾ IEC Ex db IIC T6 ... T1 Ga/Gb, Gb ⁽¹⁾⁽⁸⁾⁽¹⁰⁾⁽¹¹⁾ IEC Ex db IIC T6 ... T1 Ga/Gb, Gb + IEC Ex t IIIC T ⁽⁸⁾⁽¹⁰⁾⁽¹¹⁾⁽¹⁹⁾ FM (NI) Class I, Div. 2, Groups A, B, C, D ⁽³⁾⁽⁵⁾⁽⁸⁾⁽⁹⁾ FM (NI) Class I, Div. 2, Groups A, B, C, D + Ship approval ⁽³⁾⁽⁵⁾⁽⁷⁾⁽⁸⁾⁽⁹⁾⁽¹⁰⁾ FM (IS) Class I, II, III, Div. 1, Groups A, B, C, D, E, F ⁽⁵⁾⁽⁸⁾⁽⁹⁾ FM (IS) Class I, II, III, Div. 1, Groups A, B, C, D, E, F, G + shipping approval ⁽⁴⁾⁽⁵⁾⁽⁷⁾⁽⁸⁾⁽⁹⁾⁽¹⁰⁾ FM (XP-AIS) Class I, II, III, Div. 1, Groups A, B, C, D, E, F, G ⁽²⁾⁽⁵⁾⁽⁸⁾⁽⁹⁾⁽¹⁰⁾ FM (XP-AIS) Class I, II, III, Div. 1, Groups A, B, C, D, E, F, G + shipping approval ⁽²⁾⁽⁵⁾⁽⁷⁾⁽⁸⁾⁽⁹⁾⁽¹⁰⁾ FM (XP) Class I, Div. 1, Groups A, B, C, D ⁽⁸⁾⁽¹⁰⁾⁽¹⁹⁾ CSA (NI) Class I, Div. 2, Groups A, B, C, D; (DIP) Class II, III, Div. 1, Groups E, F, G ⁽¹⁾⁽⁵⁾⁽¹⁰⁾ CSA (IS) Class I, II, III, Div. 1, Groups A, B, C, D, E, F, G ⁽⁵⁾⁽⁸⁾ CSA (XP-IS) Class I, II, III, Div. 1, Groups A, B, C, D, E, F, G ⁽²⁾⁽⁵⁾⁽⁸⁾⁽⁹⁾⁽¹⁰⁾ CSA (XP) Class I, II, III, Div. 1, Groups A, B, C, D, E, F, G ⁽⁸⁾⁽⁹⁾⁽¹⁰⁾⁽¹¹⁾⁽¹⁹⁾ NEPSI Ex ia IIC T6 ⁽⁵⁾⁽⁸⁾ NEPSI Ex ia IIC T6 + DIP A20/21 TA T* ⁽¹⁾⁽⁵⁾⁽⁸⁾ NERSI Ex d ia IIC T6 ⁽²⁾⁽⁵⁾⁽⁸⁾⁽⁹⁾⁽¹⁰⁾ NEPSI Ex d ia IIC T6 + DIP A20/21 TA T* ⁽²⁾⁽⁵⁾⁽⁸⁾⁽⁹⁾⁽¹⁰⁾ NEPSI Ex d IIC T6 ⁽⁸⁾⁽¹⁰⁾⁽¹⁹⁾ NEPSI Ex d IIC T6 + DIP A20/21 TA T* ⁽⁸⁾⁽¹⁰⁾⁽¹⁹⁾ NEPSI DIP A20/21 TA T* ⁽¹⁾⁽⁸⁾ INMETRO Ex ia IIC T6 ... T1 ⁽⁵⁾⁽⁸⁾ | 0 A 0 B 0 C 0 E 0 F 0 G 0 H 0 J 0 L 0 M 0 N 0 W 0 Q 0 R 0 S 0 T 0 U 1 A 1 B 1 C 1 D 1 F 1 G 1 H 1 J 1 K 1 L 1 M 1 N 1 P 1 Q 1 R 2 A 2 B 2 C 2 D 2 E 2 F 2 G 3 A | Continuous, contact, 60 m (197 ft) range. Monitors level in solids. INMETRO Ex t IIIC T* IP6X, Da, Da/Db, Da/Dc, Db + Ex ia IIC T6, Ga, Ga/Gb ⁽¹⁾⁽⁵⁾⁽⁸⁾⁽¹⁰⁾ INMETRO Ex d ia IIC T6 ... T1 ⁽²⁾⁽⁵⁾⁽⁸⁾⁽⁹⁾⁽¹⁰⁾ INMETRO Ex t IIIC T* IP6X, Da, Da/Db, Da/Dc, Db + Ex d ia IIC T6 Ga/Gb ⁽²⁾⁽⁵⁾⁽⁸⁾⁽⁹⁾⁽¹⁰⁾ INMETRO Ex d IIC T6 ... T1 ⁽⁸⁾⁽¹⁰⁾⁽¹⁹⁾ INMETRO Ex t IIIC T* IP6X, Da, Da/Db, Da/Dc, Db + Ex d IIC T6 Ga/Gb ⁽⁸⁾⁽¹⁰⁾⁽¹⁹⁾ INMETRO Ex t IIIC T* IP6X, Da, Da/Db, Da/Dc, Db ⁽¹⁾⁽⁵⁾⁽⁸⁾⁽¹⁰⁾ KOSHA Ex d IIC T6 ... T1 - KE ⁽⁸⁾⁽¹⁰⁾⁽¹⁹⁾ Korea KC ex free area ⁽⁸⁾ GOST-R/EAC 0 Ex ia IIC T1 ... T6 X ⁽⁸⁾ GOST-R/EAC 0 Ex ia IIC T1 ... T6 X + Ex t IIIC T ... IP66 ⁽¹⁾⁽⁸⁾ GOST-R/EAC 1 Ex d ia IIC T1 ... T6 X ⁽²⁾⁽⁸⁾⁽⁹⁾⁽¹⁰⁾ GOST-R/EAC 1 Ex d ia IIC T1 ... T6 X + Ex t IIIC T ... IP66 ⁽²⁾⁽⁸⁾⁽⁹⁾⁽¹⁰⁾ GOST-R/EAC 1 Ex d IIC T1 ... T6 X ⁽⁸⁾⁽¹⁰⁾⁽¹⁹⁾ GOST-R/EAC 0 Ex d IIC T1 ... T6 X + Ex t IIIC T ... IP66 ⁽⁸⁾⁽¹⁰⁾⁽¹⁹⁾ GOST-R/EAC Ex t IIIC T ... IP66 ⁽¹⁾⁽⁸⁾ Note: Version/Material, Process fitting/Material, and Length options are available only with options of corresponding type. Probe version/Material Probe exchangeable cable ø 4 mm (0.16 inch) with gravity weight/316 ⁽³⁾⁽¹⁴⁾ Probe exchangeable cable ø 6 mm (0.24 inch) with gravity weight/316 ⁽³⁾⁽¹⁴⁾ Probe exchangeable cable ø 6 mm (0.24 inch) with gravity weight/PA coated ⁽¹⁵⁾ Probe exchangeable cable ø 11 mm (0.43 inch) with gravity weight/PA coated ⁽¹⁵⁾ Probe exchangeable rod ø 16 mm (0.63 inch)/316L ⁽¹³⁾ Process fitting/Material Thread G 3/4" (DIN 3852-A) PN 40/316L Thread 3/4" NPT (ASME B1.20.1) PN 40/316L Thread G 1" (DIN 3852-A) PN 40/316L Thread 1" NPT (ASME B1.20.1) PN 40/316L Thread G 1 1/2" (DIN 3852-A) PN 40/316L Thread 1 1/2" NPT (ASME B1.20.1) PN 40/316L Thread G 2" (DIN 3852-A) PN 40/316L Flange DN 50 PN 40 Form C, DIN 2501/316L Flange DN 80 PN 40 Form C, DIN 2501/316L Flange DN 100 PN 16 Form C, DIN 2501/316L Flange DN 100 PN 40 Form C, DIN 2501/316L Flange DN 150 PN 16 Form C, DIN 2501/316L Flange DN 50 PN 40 EN 1092-1 Form B1/316L Flange DN 80 PN 40 EN 1092-1 Form B1/316L Flange DN 100 PN 16 EN 1092-1 Form B1/316L Flange 2" 150 lb RF, ASME B16.5/316L Flange 2" 300 lb RF, ASME B16.5/316L Flange 3" 150 lb RF, ASME B16.5/316L Flange 3" 300 lb RF, ASME B16.5/316L Flange 4" 150 lb RF, ASME B16.5/316L Flange 4" 300 lb RF, ASME B16.5/316L Flange 6" 150 lb RF, ASME B16.5/316L | 3 B 3 C 3 D 3 E 3 F 3 G 4 A 6 A 5 A 5 B 5 C 5 D 5 E 5 F 5 G A B C D E 0 0 0 1 0 2 0 3 0 4 0 5 0 6 1 0 1 2 1 3 1 4 1 5 1 6 1 7 1 8 3 0 3 2 3 3 3 4 3 5 3 6 3 7 |



Level measurement

Continuous level measurement
Guided wave radar transmitters

SITRANS LG series

Selection and ordering data

Article No.

Article No.

| SITRANS LG260 Guided radar level transmitter | 7ML5882- | Ord. code |
|--|----------|-----------|
| Continuous, contact, 60 m (197 ft) range. Monitors level in solids. | - | |
| Electronics | | |
| Two-wire 4 ... 20 mA/HART | 0 | |
| Four-wire Modbus ²⁾⁹⁾¹⁰⁾ | 1 | |
| Two-wire 4 ... 20 mA/HART with SIL qualification ⁹⁾ | 2 | |
| Four-wire 4 ... 20 mA/HART; 90 ... 253 V AC; 50/60 Hz ²⁾⁹⁾¹⁰⁾ | 3 | |
| Four-wire 4 ... 20 mA/HART; 9.6 ... 48 V DC; 20 ... 42 V AC ²⁾⁹⁾¹⁰⁾ | 4 | |
| PROFIBUS PA ⁹⁾ | 5 | |
| FOUNDATION Fieldbus ⁹⁾ | 6 | |
| Seal/Process temperature | | |
| FKM (SHS FPM 70C3 GLT)/-40 ... +80 °C (-40 ... +176 °F) ¹⁶⁾ | A | |
| FKM (SHS FPM 70C3 GLT)/-40 ... +150 °C (-40 ... +302 °F) | B | |
| FFKM (Kalrez 6375)/-20 ... +200 °C (-4 ... +392 °F) | C | |
| EPDM (A+P 70.10-02)/-40 ... +80 °C (-40 ... +176 °F) ¹⁶⁾ | D | |
| EPDM (A+P 70.10-02)/-40 ... +150 °C (-40 ... +392 °F) | E | |
| Housing/Protection/Cable | | |
| Note: for installation of remote display, 7ML5840, with LG two chamber housing options, contact PVC | | |
| Plastic IP66/IP67 M20 x 1.5/ blind stopper ⁹⁾¹⁰⁾ | A | |
| Plastic IP66/IP67 1/2" NPT/blind stopper ⁹⁾¹⁰⁾ | B | |
| Plastic 2-chamber/IP66/IP67/M20 x 1.5/ blind stopper | C | |
| Plastic 2-chamber/IP66/IP67/ 1/2" NPT/ blind stopper | D | |
| Aluminum/IP66/IP68 (0.2 bar) M20 x 1.5/blind stopper ⁹⁾¹⁰⁾ | E | |
| Aluminum/IP66/IP68 (0.2 bar) 1/2" NPT/ blind stopper ⁹⁾¹⁰⁾ | F | |
| Aluminum double chamber/IP66/IP68 (0.2 bar) M20 x 1.5/blind stopper | G | |
| Aluminum double chamber/IP66/ IP68 (0.2 bar) 1/2" NPT/blind stopper | H | |
| Stainless Steel (precision casting) 316L/IP66/IP68 (0.2 bar) M20 x 1.5/ blind stopper ⁹⁾¹⁰⁾ | J | |
| Stainless steel (precision casting) 316L/IP66/IP68 (0.2 bar) 1/2" NPT/ blind stopper ⁹⁾¹⁰⁾ | K | |
| Stainless steel (electropolished) 316L/IP66/IP68 (0.2 bar) M20 x 1.5/ blind stopper ⁹⁾¹⁰⁾ | L | |
| Stainless steel (electropolished) 316L/IP66/IP68 (0.2 bar) 1/2" NPT/ blind stopper ⁹⁾¹⁰⁾ | M | |
| Stainless steel double chamber/IP66/IP68 (0.2 bar) M20 x 1.5/blind stopper | N | |
| Stainless steel double chamber/IP66/ IP68 (0.2 bar) 1/2" NPT/blind stopper | P | |
| Aluminum/IP66/IP68 (0.2 bar) M20 x 1.5/cable gland stainless steel ⁹⁾¹⁰⁾ | Q | |

| SITRANS LG260 Guided radar level transmitter | 7ML5882- | Ord. code |
|---|----------|-----------|
| Continuous, contact, 60 m (197 ft) range. Monitors level in solids. | - | |
| Aluminum double chamber/IP66/IP68 (0.2 bar) M20 x 1.5/cable gland stainless steel | | R |
| Stainless steel (precision casting) 316L/ IP66/ IP68 (0.2 bar) M20 x 1.5/cable gland stainless steel ⁹⁾¹⁰⁾ | | S |
| Stainless steel (electropolished) 316L/IP66/IP68 (0.2 bar) M20 x 1.5/ cable gland stainless steel ⁹⁾¹⁰⁾ | | T |
| Aluminum single chamber/IP66/IP68 (0.2 bar) M20 x 1.5/cable gland brass nickel-plated | | W |
| Aluminum double chamber/IP66/IP68 (0.2 bar) M20 x 1.5/cable gland brass nickel-plated | | X |
| Stainless steel single chamber (precision casting)/IP66/IP68 (0.2 bar) M20 x 1.5/cable gland brass nickel-plated | | Y |
| Stainless steel double chamber/IP66/IP68 (0.2 bar) M20 x 1.5/cable gland brass nickel-plated | | U |
| Remote stainless steel single chamber housing, electropolished/IP66/IP67 with cable outlet IP68 (electronics separated by cable); M20 x 1.5/blind plug ¹⁰⁾ | Z | Q2 A |
| Remote plastic single chamber housing /IP66/IP67 with cable outlet IP68 (electronics separated by cable); M20 x 1.5/blind plug ¹⁰⁾ | Z | Q2 B |
| Lengths | | |
| Rod ø 16 mm/316L | | |
| 500 mm (19.69 inch) | | 0 |
| 501 ... 1 000 mm (19.72 ... 39.37 inch) | | 1 |
| 1 001 ... 2 000 mm (39.41 ... 78.74 inch) | | 2 |
| 2 001 ... 3 000 mm (78.78 ... 118.11 inch) | | 3 |
| 3 001 ... 4 000 mm (118.15 ... 157.48 inch) | | 4 |
| 4 001 ... 5 000 mm (157.52 ... 196.85 inch) | | 5 |
| 5 001 ... 6 000 mm (196.89 ... 236.22 inch) | | 6 |
| Cable lengths ø 4 mm/316 | | |
| 501 ... 1 000 mm (19.72 ... 39.37 inch) | | 9 R2 E |
| 1 001 ... 5 000 mm (39.41 ... 196.85 inch) | | 9 R2 F |
| 5 001 ... 10 000 mm (196.89 ... 393.70 inch) | | 9 R2 G |
| 10 001 ... 15 000 mm (393.74 ... 590.55 inch) | | 9 R2 H |
| 15 001 ... 20 000 mm (590.59 ... 787.40 inch) | | 9 R2 J |
| 20 001 ... 25 000 mm (787.44 ... 984.25 inch) | | 9 R2 K |
| 25 001 ... 30 000 mm (984.29 ... 1 181.10 inch) | | 9 R2 L |
| 30 001 ... 35 000 mm (1 181.14 ... 1 377.95 inch) | | 9 R2 M |
| 35 001 ... 40 000 mm (1 377.99 ... 1 574.80 inch) | | 9 R2 N |
| 40 001 ... 45 000 mm (1 574.84 ... 1 771.65 inch) | | 9 R2 P |
| 45 001 ... 50 000 mm (1 771.69 ... 1 968.50 inch) | | 9 R2 Q |
| 50 001 ... 55 000 mm (1 968.54 ... 2 165.35 inch) | | 9 R2 R |
| 55 001 ... 60 000 mm (2 165.39 ... 2 362.20 inch) | | 9 R2 S |



| Selection and ordering data | Article No. | Ord. code | Order code |
|---|-----------------|-----------|--|
| SITRANS LG260 Guided radar level transmitter | 7ML5882- | Ord. code | |
| Continuous, contact, 60 m (197 ft) range. Monitors level in solids. | | | |
| <u>Cable lengths ø 6 mm/316L</u> | | | |
| 500 mm (19.69 inch) | | 9 R 4 A | |
| 501 ... 1 000 mm (19.72 ... 39.37 inch) | | 9 R 4 B | |
| 1 001 ... 5 000 mm (39.41 ... 196.85 inch) | | 9 R 4 C | |
| 5 001 ... 10 000 mm (196.89 ... 393.70 inch) | | 9 R 4 D | |
| 10 001 ... 15 000 mm (393.74 ... 590.55 inch) | | 9 R 4 E | |
| 15 001 ... 20 000 mm (590.59 ... 787.40 inch) | | 9 R 4 F | |
| 20 001 ... 25 000 mm (787.44 ... 984.25 inch) | | 9 R 4 G | |
| 25 001 ... 30 000 mm (984.29 ... 1 181.10 inch) | | 9 R 4 H | |
| 30 001 ... 35 000 mm (1 181.14 ... 1 377.95 inch) | | 9 R 4 J | |
| 35 001 ... 40 000 mm (1 377.99 ... 1 574.80 inch) | | 9 R 4 K | |
| 40 001 ... 45 000 mm (1 574.84 ... 1 771.65 inch) | | 9 R 4 L | |
| 45 001 ... 50 000 mm (1 771.69 ... 1 968.50 inch) | | 9 R 4 M | |
| 50 001 ... 55 000 mm (1 968.54 ... 2 165.35 inch) | | 9 R 4 N | |
| 55 001 ... 60 000 mm (2 165.39 ... 2 362.20 inch) | | 9 R 4 P | |
| <u>Cable lengths ø 6 mm or ø 11 mm/PA coated</u> | | | |
| 501 ... 1 000 mm (19.72 ... 39.37 inch) | | 9 R 6 A | |
| 1 001 ... 5 000 mm (39.41 ... 196.85 inch) | | 9 R 6 B | |
| 5 001 ... 10 000 mm (196.89 ... 393.70 inch) | | 9 R 6 C | |
| 10 001 ... 15 000 mm (393.74 ... 590.55 inch) | | 9 R 6 D | |
| 15 001 ... 20 000 mm (590.59 ... 787.40 inch) | | 9 R 6 E | |
| 20 001 ... 25 000 mm (787.44 ... 984.25 inch) | | 9 R 6 F | |
| 25 001 ... 30 000 mm (984.29 ... 1 181.10 inch) | | 9 R 6 G | |
| 30 001 ... 35 000 mm (1 181.14 ... 1 377.95 inch) | | 9 R 6 H | |
| 35 001 ... 40 000 mm (1 377.99 ... 1 574.80 inch) | | 9 R 6 J | |
| 40 001 ... 45 000 mm (1 574.84 ... 1 771.65 inch) | | 9 R 6 K | |
| 45 001 ... 50 000 mm (1 771.69 ... 1 968.50 inch) | | 9 R 6 L | |
| 50 001 ... 55 000 mm (1 968.54 ... 2 165.35 inch) | | 9 R 6 M | |
| 55 001 ... 65 000 mm (2 165.39 ... 2 559.06 inch) | | 9 R 6 N | |
| | | | Further designs (mandatory) |
| | | | Please add "-Z" to Article No. and specify Order code(s). |
| | | | Supplementary electronics |
| | | | Without A00 |
| | | | Additional current output 4 ... 20 mA ¹⁰⁾ A01 |
| | | | Rod mounted |
| | | | Without Rod, applicable for coax or cable probe types only C00 |
| | | | Mounted C01 |
| | | | Not mounted C02 |
| | | | Indicating/adjustment module |
| | | | Without E00 |
| | | | Mounted E01 |
| | | | Laterally mounted E02 |
| | | | Language of display |
| | | | German L00 |
| | | | English L01 |
| | | | French L02 |
| | | | Dutch L03 |
| | | | Italian L04 |
| | | | Spanish L05 |
| | | | Portuguese L06 |
| | | | Russian L07 |
| | | | Chinese L08 |
| | | | Japanese L09 |
| | | | No language pre-set L10 |
| | | | Operating instructions |
| | | | German M00 |
| | | | English M01 |
| | | | French M02 |
| | | | Spanish M03 |
| | | | Further designs (optional) |
| | | | Please add "-Z" to Article No. and specify Order code(s). |
| | | | Enter the total insertion length in plain text description Y01 |
| | | | Remote electronic cable lengths: 2 m (6.6 ft). Only available with Housing options Q2A and Q2B. Y10 |
| | | | Remote electronic cable lengths: 5 m (16.4 ft). Only available with Housing options Q2A and Q2B. Y11 |
| | | | Remote electronic cable lengths: 10 m (32.8 ft). Only available with Housing options Q2A and Q2B. Y12 |
| | | | Identification Label (measurement loop) stainless steel, 40 characters max, add in plain text. To add more than one line use a coma "," for line break. Y17 |
| | | | Identification Label (measurement loop) foil, 40 characters max, add in plain text. To add more than one line use a coma "," for line break. Y18 |

Level measurement

Continuous level measurement Guided wave radar transmitters

SITRANS LG series

Selection and ordering data

Article No.

| | |
|--|------------|
| Material Inspection certificate 3.1 of EN 10204 | C05 |
| 3.1-Inspection Certificate for instrument (EN 10204) ¹⁷⁾ | C12 |
| Inspection certificate 3.1 (EN 10204, NACE MR 0175) - material. ¹⁷⁾¹⁸⁾ Note: 316L probes include NACE MR 0175 and MR 0103, non 316L probes include MR 0175 only and plated flange designs are not available with NACE certificate. | D07 |
| 3.1-Inspection Certificate for instrument with test data (EN 10204) ¹⁷⁾ | C25 |
| 2.2-Factory certificate for material (EN 10204) ¹⁷⁾ | C15 |
| Quality and test plan ¹⁷⁾ | C26 |
| Dye penetration test, results confirmed via a 3.1 certificate/instrument (EN10204) ¹⁷⁾ | C13 |
| X-ray test + 3.1 certificate/instrument ¹⁷⁾ | C14 |
| Positive material identification test + 3.1 certificate/instrument ¹⁷⁾ | C16 |
| Roughness test + 3.1 certificate/instrument ¹⁷⁾ | C18 |
| Pressure test + 3.1 certificate/instrument ¹⁷⁾ | C31 |
| Helium leak test + 3.1 certificate/instrument ¹⁷⁾ | C32 |
| Pressure test according to Norsok + 3.1 certificate/instrument ¹⁷⁾ | C61 |
| 5 point calibration certificate (min. length 500 mm) ¹⁷⁾ | C62 |

Operating Instructions

All literature is available to download for free, in a range of languages, at

<http://www.siemens.com/processinstrumentation/documentation>

Accessories

| | Article No. |
|---|---------------------------|
| SITRANS LG series/SITRANS RD150 sensor display module | A5E34143449 |
| SITRANS LG, two-wire 4 ... 20 mA/HART electronic | A5E35637821 |
| SITRANS LG, USB communicator | A5E35192015 |
| SITRANS LG, Mounting eye M12 x 20 | PBD:51041448 |
| SITRANS LG, Mounting spring | PBD:51041449 |
| Siemens Intrinsically Safe Barrier (DC powered), ATEX II 1 G EEx ia | 7NG4124-0AA00 |
| SITRANS RD100, loop powered display - see Chapter 7 | 7ML5741-.....- |
| SITRANS RD150, remote digital display for 4 ... 20 mA and HART devices - see Chapter 7 | 7ML5742-.....-.... |
| SITRANS RD200, universal input display with Modbus conversion - see Chapter 7 | 7ML5740-.....-.. |
| SITRANS RD300, dual line display with totalizer and linearization curve and Modbus conversion - see Chapter 7 | 7ML5744-.....-.. |
| For applicable back up point level switch - see point level measurement section | |

Note: some configuration options are not available.

For restriction information see the online PIA configuration tool.

Note: Please consult manual for further details.

- 1) Not available with Plastic and Stainless steel (electropolished) Housing/Protection/Cable options and certain glands.
- 2) Available only with Double chamber, Metallic Housing/Protection/Cable options and certain glands.
- 3) Not available with Remote and Stainless steel (electropolished) Housing/Protection/Cable options and certain glands.
- 4) Not available with Stainless steel (electropolished) Housing/Protection/Cable options and certain glands.
- 5) Not available with Seal/Process temperature option C.
- 6) Not available with Housing/Protection/Cable options W, X, Y, and U.
- 7) Not available with Probe version/Material option E.
- 8) Available only with certain Electronics options.
- 9) Available only with Supplementary electronic option A00.
- 10) Not available with Indicating/adjustment module option E02.
- 11) Not available with Seal/Process temperature options B and E.
- 12) Available only with Seal/Process temperature option C.
- 13) Not available with Seal/Process temperature options A and D.
- 14) Available only with Rod mounted option C00.
- 15) Available only with Seal/Process temperature options A and D.
- 16) Not available with Housing/Protection/Cable options Q2A and Q2B.
- 17) Listed Certificates are not available with all configurations, please contact factory for more information.
- 18) Available only with 316L Probes. NACE is not available with coated, plated, or hygienic connections.
- 19) Available only with Single chamber, Aluminum and Stainless steel (precision casting) Housing/Protection/Cable options.

| Selection and ordering data | Article No. | Article No. | |
|---|---|---|---|
| SITRANS LG270 Guided radar level transmitter Continuous, contact, 60 m (197 ft) range. Monitors level and interface in liquids in extreme environments. ↗ Click on the Article No. for the online configuration in the PIA Life Cycle Portal. | 7ML5883- Ord. code | SITRANS LG270 Guided radar level transmitter Continuous, contact, 60 m (197 ft) range. Monitors level and interface in liquids in extreme environments. | |
| Approvals General purpose (CSA, FM, CE) ³²⁾ Shipping approval ¹⁾²⁾³⁾⁴⁾⁵⁾ Overfill protection (WHG; VLAREM) ²⁾³⁾ ATEX II 1G, 1/2G, 2G Ex ia IIC T6 ²⁾³²⁾ ATEX II 1G, 1/2G, 2G Ex ia IIC + Overfill (WHG; VLAREM) ²⁾³⁾ ATEX II 1G, 1/2G, 2G Ex ia IIC T6 + shipping approval ¹⁾²⁾³⁾⁴⁾⁵⁾ ATEX II 1G, 1/2G, 2G Ex ia IIC + ATEX II 1D, 1/2D, 2D IP6x ²⁾⁷⁾ ATEX II 1/2G, 2G Ex d ia IIC T6 ²⁾⁵⁾⁶⁾⁸⁾³²⁾ ATEX II 1/2G, 2G Ex d ia IIC + shipping approval ¹⁾²⁾³⁾⁵⁾⁶⁾⁸⁾ ATEX II 1/2G, 2G Ex d ia IIC + ATEX II 1/2D, 2D IP6x ²⁾⁵⁾⁶⁾⁸⁾ ATEX II 1/2G, 2G Ex d IIC T6 ⁶⁾⁷⁾³²⁾ ATEX II 1G, II 1/2G, II 2G Ex ia IIC T6 ... T1 Ga, Ga/Gb, Gb /IEC Ex ia IIC T6 ... T1 Ga, Ga/Gb, Gb ²⁾³⁾ ATEX II 1/2G, 2G Ex d IIC + ship approval ¹⁾²⁾³⁾⁵⁾⁶⁾⁷⁾ ATEX II 1/2G, 2G Ex d IIC + ATEX II 1/2D, 2D IP6x ²⁾⁶⁾⁷⁾ ATEX II 1D, 1/2D, 2D IP6x T ²⁾⁷⁾ ATEX II 1/2G, II 2G Ex db IIC T6 ... T1 Ga/Gb, Gb + Overfill protection (WHG, VLAREM) ⁶⁾⁷⁾³²⁾ IEC Ex ia IIC T6 ²⁾ IEC Ex ia IIC T6 + IEC IP6x T tD ²⁾⁷⁾³²⁾ IEC Ex d ia IIC T6 ²⁾⁵⁾⁶⁾⁸⁾³²⁾ IEC Ex d ia IIC T6 + IEC IP6x T tD ²⁾⁵⁾⁶⁾⁸⁾ IEC Ex d IIC T6 ³⁾⁶⁾⁷⁾ IEC Ex d IIC T6 + IEC IP6x T tD ²⁾³⁾⁶⁾⁷⁾ IEC Ex db IIC T6 ... T1 Ga/Gb, Gb + Ship approval ²⁾³⁾⁵⁾⁶⁾⁷⁾⁹⁾ IEC Ex ia IIC T6 ... T1 Ga, Ga/Gb, Gb + Ship approval ²⁾⁹⁾¹²⁾ IEC Ex d ia IIC T6 ... T1 Ga/Gb, Gb + Ship approval ²⁾⁵⁾⁶⁾⁸⁾⁹⁾ FM (NI) Class I, Div. 2, Groups A, B, C, D ²⁾⁵⁾¹⁰⁾³²⁾ FM (NI) Class I, Div. 2, Groups A, B, C, D + ship approval ¹⁾²⁾³⁾⁵⁾⁸⁾ FM (IS) Class I, II, III, Div. 1, Groups A, B, C, D, E, F ²⁾⁵⁾³²⁾ FM (IS) Class I, II, III, Div. 1, Groups A, B, C, D, E, F, G + ship approval ¹⁾²⁾³⁾⁴⁾⁵⁾ FM (XP-AIS) Class I, II, III, Div. 1, Groups A, B, C, D, E, F, G ²⁾⁵⁾⁶⁾⁸⁾³²⁾ FM (XP-AIS) Class I, II, III, Div. 1, Groups A, B, C, D, E, F, G + shipping approval ¹⁾²⁾³⁾⁵⁾⁶⁾⁸⁾ FM (XP) Class I, Div. 1, Groups A, B, C, D ⁶⁾¹¹⁾³²⁾ CSA (NI) Class I, Div. 2, Groups A, B, C, D; (DIP) Class II, III, Div. 1, Groups E, F, G ³⁾⁶⁾⁷⁾ CSA (IS) Class I, II, III, Div. 1, Groups A, B, C, D, E, F, G ²⁾³⁾ CSA (XP-IS) Class I, II, III, Div. 1, Groups A, B, C, D, E, F, G ²⁾³⁾⁵⁾⁶⁾⁸⁾ CSA (XP) Class I, II, III, Div. 1, Groups A, B, C, D, E, F, G ³⁾⁵⁾⁶⁾¹¹⁾¹⁹⁾ CSA (NI) Class I, II, III Div. 2, Groups A, B, C, D, F, G + Ship approval ²⁾³⁾⁶⁾⁷⁾⁹⁾ | 0 A 0 B 0 C 0 E 0 F 0 G 0 H 0 J 0 L 0 M 0 N 0 W 0 Q 0 R 0 S 7 P 0 T 0 U 1 A 1 B 1 C 1 D 7 C 7 D 7 E 1 F 1 G 1 H 1 J 1 K 1 L 1 M 1 N 1 P 1 Q 1 R 7 K | CSA (IS) Class I, II, III, Div. 1, Groups A, B, C, D, E, F, G + Ship approval ²⁾⁶⁾⁹⁾¹²⁾ CSA (XP-IS) Class I, II, III, Div. 1, Groups A, B, C, D, E, F, G + Ship approval ²⁾³⁾⁵⁾⁶⁾⁸⁾⁹⁾ NEPSI Ex ia IIC T6 ²⁾³⁾ NEPSI Ex ia IIC T6 + DIP A20/21 TA T* ²⁾⁵⁾⁷⁾ NERSI Ex d ia IIC T6 ²⁾³⁾⁵⁾⁶⁾⁸⁾ NEPSI Ex d ia IIC T6 + DIP A20/21 TA T* ²⁾³⁾⁵⁾⁶⁾⁸⁾ NEPSI Ex d IIC T6 ²⁾³⁾⁶⁾¹¹⁾ NEPSI Ex d IIC T6 + DIP A20/21 TA T* ²⁾³⁾⁶⁾¹¹⁾ NEPSI DIP A20/21 TA T* ²⁾³⁾⁷⁾ INMETRO Ex ia IIC T6 ... T1 ²⁾³²⁾ INMETRO Ex t IIIC T* IP6X, Da, Da/Db, Da/Dc, Db + Ex ia IIC T6, Ga, Ga/Gb ²⁾⁶⁾⁷⁾ INMETRO Ex d ia IIC T6 ... T1 ²⁾⁵⁾⁶⁾⁸⁾³²⁾ INMETRO Ex t IIIC T* IP6X, Da, Da/Db, Da/Dc, Db + Ex d ia IIC T6 Ga/Gb ²⁾⁵⁾⁶⁾⁸⁾ INMETRO Ex d IIC T6 ... T1 ²⁾⁶⁾¹¹⁾³²⁾ INMETRO Ex t IIIC T* IP6X, Da, Da/Db, Da/Dc, Db + Ex d IIC T6 Ga/Gb ²⁾⁶⁾¹¹⁾ INMETRO Ex t IIIC T* IP6X, Da, Da/Db, Da/Dc, Db ²⁾⁶⁾⁷⁾ KOSHA Ex d IIC T6 ... T1 – KE ²⁾³⁾⁶⁾¹¹⁾ Korea KC ex free area ²⁾³²⁾ GOST-R/EAC 0 Ex ia IIC T1 ... T6 X ²⁾¹³⁾ GOST-R/EAC 0 Ex ia IIC T1 ... T6 X + Ex t IIIC T ... IP66 ²⁾⁷⁾ GOST-R/EAC 1 Ex d ia IIC T1 ... T6 X ²⁾⁵⁾⁶⁾⁸⁾ GOST-R/EAC 1 Ex d ia IIC T1 ... T6 X + Ex t IIIC T ... IP66 ²⁾⁵⁾⁶⁾⁸⁾ GOST-R/EAC 1 Ex d IIC T1 ... T6 X ²⁾⁶⁾¹¹⁾ GOST-R/EAC 0 Ex d IIC T1 ... T6 X + Ex t IIIC T ... IP66 ²⁾⁶⁾¹¹⁾ GOST-R/EAC Ex t IIIC T ... IP66 ²⁾¹⁴⁾ | 7 L 7 M 2 A 2 B 2 C 2 D 2 E 2 F 2 G 3 A 3 B 3 C 3 D 3 E 3 F 3 G 4 A 6 A 5 A 5 B 5 C 5 D 5 E 5 F 5 G |
| Note: Version/Material, Process fitting/Material, and Length options are available only with options of corresponding type. | | | |
| Version/Material Probe exchangeable cable ø 2 mm (0.08 inch) with gravity weight/316L ¹⁵⁾¹⁶⁾¹⁷⁾ Probe exchangeable cable ø 2 mm (0.08 inch) center weight/316L ¹⁵⁾¹⁷⁾¹⁸⁾ Probe exchangeable cable ø 4 mm (0.16 inch) with gravity weight/316L ¹⁵⁾¹⁶⁾¹⁷⁾ Probe exchangeable cable ø 4 mm (0.16 inch) with center weight/316L ¹⁵⁾¹⁷⁾¹⁸⁾ Probe exchangeable rod ø 16 mm (0.63 inch)/316L ¹⁶⁾¹⁹⁾²⁰⁾ Probe coax version ø 42.2 mm (1.66 inch) with multiple hole/316L ¹⁶⁾¹⁷⁾²⁰⁾ Probe coax version ø 42.2 mm (1.66 inch); multiple hole; reference distances/316L ¹⁶⁾¹⁷⁾²⁰⁾²¹⁾²⁶⁾ Probe exchangeable cable ø 4 mm (0.16 inch) with gravity weight/Alloy C22 (2.4602) ²²⁾³⁰⁾ Probe exchangeable rod ø 16 mm (0.63 inch)/Alloy C22 (2.4602) ²²⁾³⁰⁾ Coax version ø 42.2 mm (1.66 inch) with multiple hole/Alloy C22 (2.4602) ²²⁾³⁰⁾ Exchangeable rod, diameter 8 mm (0.32 inch)/316L ¹⁹⁾²³⁾ Coax ø 21.3 mm (0.838 inch) with multiple hole/316L ²³⁾ | | A B C D E F G H J K L M | |



Level measurement

Continuous level measurement
Guided wave radar transmitters

SITRANS LG series

Selection and ordering data

Article No.

Article No.

| SITRANS LG270 Guided radar level transmitter | 7ML5883- | Ord. code |
|--|----------|-----------|
| Continuous, contact, 60 m (197 ft) range. Monitors level and interface in liquids in extreme environments. | | |
| Process fitting/Material | | |
| Thread G 1 1/2" (DIN 3852-A) PN 400/316L ²⁰⁾ | 0 0 | |
| Thread 1 1/2" NPT (ASME B1.20.1) PN 400/316L ²⁰⁾ | 0 1 | |
| Thread G1 1/2" PN 400, DIN 3852-A/ Alloy C22 (2.4602) | 0 2 | |
| Thread 1 1/2" NPT PN 400, ASME B1.20.1/ Alloy C22 (2.4602) | 0 3 | |
| Flange DN 50 PN 40 Form C, DIN 2501/316L with Alloy C22 (2.4602) coating | 0 4 | |
| Flange DN 80 PN 40 Form C, DIN 2501/316L with Alloy C22 (2.4602) coating | 0 5 | |
| Flange DN 100 PN 16 Form C, DIN 2501/316L with Alloy C22 (2.4602) coating | 0 6 | |
| Flange DN 50 PN 40 Form B1, EN 1092-1/316L with Alloy C22 (2.4602) coating | 0 7 | |
| Flange DN 50 PN 63 Form B1, EN 1092-1/316L with Alloy C22 | 0 8 | |
| Flange DN 50 PN 40 Form C, DIN 2501/316L | 1 0 | |
| Flange DN 50 PN 40 form V13, DIN 2513/316L | 1 1 | |
| Flange DN 65 PN 64 Form V13, DIN 2501/316L | 1 2 | |
| Flange DN 80 PN 40 Form C, DIN 2501/316L | 1 3 | |
| Flange DN 80 PN 40 Form V13, DIN 2501/316L | 1 4 | |
| Flange DN 80 PN 100 Form L, DIN 2501/316L ²⁰⁾ | 1 5 | |
| Flange DN 100 PN 16 Form C, DIN 2501/316L | 1 6 | |
| Flange DN 100 PN 16 Form V13, DIN 2501/316L | 1 7 | |
| Flange DN 100 PN 40 Form C, DIN 2501/316L | 1 8 | |
| Flange DN 100 PN 40 Form V13, DIN 2513/316L | 2 0 | |
| Flange DN 150 PN 16 Form C, DIN 2501/316L | 2 1 | |
| Flange DN 50 PN 40 EN 1092-1 Form B1/316L | 2 2 | |
| Flange DN 100 PN 160 GOST 12815-80.7/316L ²⁰⁾ | 2 3 | |
| Flange 2" 150 lb RF, ASME B16.5/316L with Alloy C22 (2.4602) coating | 2 4 | |
| Flange 2" 300 lb RF, ASME B16.5/316L with Alloy C22 (2.4602) coating | 2 5 | |
| Flange 2" 600 lb RF, ASME B16.5/316L with Alloy C22 (2.4602) coating | 2 6 | |
| Flange 3" 150 lb RF, ASME B16.5/316L with Alloy C22 (2.4602) coating | 2 7 | |
| Flange 3" 300 lb RF, ASME B16.5/316L with Alloy C22 (2.4602) coating | 2 8 | |
| Flange DN 80 PN 160 Form C, DIN 2501/316L ²⁰⁾ | 6 0 | |
| Flange DN 80 PN 250 Form L, DIN 2501/316L ²⁰⁾ | 6 1 | |
| Flange DN 50 PN 160, EN 1092-1 Form B1/316L ²⁰⁾ | 6 2 | |
| Flange DN 50 PN 160, EN 1092-1 Form B2/316L ²⁰⁾ | 6 3 | |
| Flange DN 50 PN 32, EN 1092-1 Form B1/316L ²⁰⁾ | 6 4 | |
| Flange DN 65 PN 250, EN 1092-1 Form B1/316L ²⁰⁾ | 6 5 | |
| Flange DN 100 PN 160, EN 1092-1 Form B2/316L ²⁰⁾ | 6 6 | |
| Flange DN 80 PN 63, EN 1092-1 Form B2/316L | 6 7 | |
| Flange 4" 600 lb RF, ASME B16.5/316L with Alloy C22 (2.4602) coating | 6 8 | |

| SITRANS LG270 Guided radar level transmitter | 7ML5883- | Ord. code |
|--|----------|-----------|
| Continuous, contact, 60 m (197 ft) range. Monitors level and interface in liquids in extreme environments. | | |
| Flange 2" 150 lb RF, ASME B16.5/316L | 3 0 | |
| Flange 2" 300 lb RF, ASME B16.5/316L | 3 1 | |
| Flange 2" 600 lb RF, ASME B16.5/316L | 3 2 | |
| Flange 2" 1 500 lb RF, ASME B16.5/316L | 3 3 | |
| Flange 3" 150 lb RF, ASME B16.5/316L | 3 4 | |
| Flange 3" 300 lb RF, ASME B16.5/316L | 3 5 | |
| Flange 3" 600 lb RF, ASME B16.5/316L | 3 6 | |
| Flange 3" 900 lb RF, ASME B16.5/316L | 3 7 | |
| Flange 3" 2 500 lb RF, ASME B16.5/316L | 3 8 | |
| Flange 3 1/2" 600 lb RF, ASME B16.5/316L | 4 0 | |
| Flange 4" 150 lb RF, ASME B16.5/316L | 4 1 | |
| Flange 4" 300 lb RF, ASME B16.5/316L | 4 2 | |
| Flange 4" 600 lb RF, ASME B16.5/316L | 4 3 | |
| Flange 6" 150 lb RF, ASME B16.5/316L | 4 4 | |
| Flange 6" 300 lb RF, ASME B16.5/316L | 4 5 | |
| Flange 6" 600 lb RF, ASME B16.5/316L | 4 6 | |
| Flange 2" 150 lb Fisher special return/316L | 4 7 | |
| Flange 3" 900 lb RJF, ASME B16.5/ Alloy C22 (2.4602) | 4 8 | |
| Flange 2" 900 lb RF, ASME B16.5/316L | 5 0 | |
| Flange 3" 1 500 lb RF, ASME B16.5/316L | 5 1 | |
| Flange 4" 900 lb RF, ASME B16.5/316L | 5 2 | |
| Flange 4" 1 500 lb RF, ASME B16.5/316L | 5 3 | |
| Flange 4" 2 500 lb RJF, ASME B16.5/316L ²⁰⁾ | 5 4 | |
| Flange 4" 1500 lb RJF, ASME B16.5/316L ²⁰⁾ | 5 5 | |
| Flange 3" 600 lb RF, ASME B16.5/316L with Alloy C22 (2.4602) coating | 5 6 | |
| Flange 4" 150 lb RF, ASME B16.5/316L with Alloy C22 (2.4602) coating | 5 7 | |
| Flange 4" 300 lb RF, ASME B16.5/316L with Alloy C22 (2.4602) coating | 5 8 | |
| Flange 6" 150 lb RF, ASME B16.5/316L with Alloy C22 (2.4602) coating | 7 0 | |
| Flange DN 50 PN 40 Form C, DIN 2501/Alloy C22 (2.4602) solid | 7 1 | |
| Flange DN 100 PN 16 Form C, DIN 2501/C22 solid | 7 2 | |
| Flange DN 100 PN 40 Form N, DIN 2501/Alloy C22 (2.4602) solid | 7 3 | |
| Flange DN 50 PN 40 Form B1, EN 1092-1/Alloy C22 (2.4602) solid | 7 4 | |
| Flange 2" 150 lb RF, ASME B16.5/ Alloy C22 (2.4602) solid | 7 5 | |
| Flange 2" 300 lb RF, ASME B16.5/ Alloy C22 (2.4602) solid | 7 6 | |
| Flange 2" 600 lb RF, ASME B16.5/ Alloy C22 (2.4602) solid | 7 7 | |
| Flange 2" 900 lb RJF, ASME B16.5/ Alloy C22 (2.4602) solid | 7 8 | |
| Flange 2" 1 500 lb RJF, ASME B16.5/ Alloy C22 (2.4602) solid | 8 0 | |
| Flange 3" 150 lb RF, ASME B16.5/ Alloy C22 (2.4602) solid | 8 1 | |
| Flange 3" 300 lb RF, ASME B16.5/ Alloy C22 (2.4602) solid | 8 2 | |
| Flange 3" 600 lb RF, ASME B16.5/ Alloy C22 (2.4602) solid | 8 3 | |
| Flange 4" 150 lb RF, ASME B16.5/ Alloy C22 (2.4602) solid | 8 4 | |
| Flange 4" 300 lb RF, ASME B16.5/ Alloy C22 (2.4602) solid | 8 5 | |
| Flange 3" 600 lb RJF for R31, ASME B16.5/ Alloy C22 (2.4602) solid | 8 6 | |

Level measurement

Continuous level measurement

Guided wave radar transmitters

SITRANS LG series

| Selection and ordering data | Article No. | Ord. code | SITRANS LG270 Guided radar level transmitter | 7ML5883- | Ord. code | SITRANS LG270 Guided radar level transmitter | 7ML5883- | Ord. code |
|--|-------------|-----------|--|----------|-----------|--|----------|-----------|
| Continuous, contact, 60 m (197 ft) range. Monitors level and interface in liquids in extreme environments. | | | | | | Continuous, contact, 60 m (197 ft) range. Monitors level and interface in liquids in extreme environments. | | |
| Flange 2" 2 500 lb RJF, ASME B16.5/ Alloy C22 (2.4602) solid | 9 0 | L 1 A | | | | Housing/Protection/Cable | | |
| Flange 3" 1 500 lb RJF, ASME B16.5/ Alloy C22 (2.4602) solid | 9 0 | L 1 B | | | | Note: for installation of remote display, 7ML5840, with LG two chamber housing options, contact PVC | | |
| Flange 3" 2 500 lb RJF, ASME B16.5/ Alloy C22 (2.4602) solid | 9 0 | L 1 C | | | | Plastic IP66/IP67 M20 x 1.5/blind stopper | A | |
| Flange 4" 600 lb RF, ASME B16.5/ Alloy C22 (2.4602) solid | 9 0 | L 1 D | | | | Plastic IP66/IP67 1/2" NPT/blind stopper | B | |
| Flange 4" 600 lb RJF, ASME B16.5/ Alloy C22 (2.4602) solid | 9 0 | L 1 E | | | | Aluminum/IP66/IP68 (0.2 bar) M20 x 1.5/blind stopper | C | |
| Flange 4" 900 lb RF, ASME B16.5/ Alloy C22 (2.4602) solid | 9 0 | L 1 F | | | | Aluminum/IP66/IP68 (0.2 bar) 1/2" NPT/ blind stopper | D | |
| Flange 4" 900 lb RJF, ASME B16.5/ Alloy C22 (2.4602) massiv | 9 0 | L 1 G | | | | Aluminum double chamber/IP66/IP68 (0.2 bar) M20 x 1.5/blind stopper | E | |
| Flange 4" 1 500 lb RJF, ASME B16.5/ Alloy C22 (2.4602) solid | 9 0 | L 1 H | | | | Aluminum double chamber/IP66/IP68 (0.2 bar) 1/2" NPT/blind stopper | F | |
| Flange 4" 2 500 lb RJF, ASME B16.5/ Alloy C22 (2.4602) solid | 9 0 | L 1 J | | | | Stainless steel (precision casting) 316L/IP66/IP68 (0.2 bar) M20 x 1.5/ blind stopper | L | |
| Flange 8" 300 lb RF, ASME B16.5/ Alloy C22 (2.4602) solid | 9 0 | L 1 K | | | | Stainless steel (precision casting) 316L/IP66/IP68 (0.2 bar) 1/2" NPT/ blind stopper | M | |
| Flange 3½" 600 lb Fisher type 249B and 259B/Alloy C22 (2.4602) solid | 9 0 | L 1 L | | | | Stainless steel (electropolished) 316L/IP66/IP68 (0.2 bar) M20 x 1.5/ blind stopper | N | |
| Flange 2½" 300 lb RF, ASME B16.5/316/316L | 9 0 | L 2 A | | | | Stainless steel (electropolished) 316L/IP66/IP68 (0.2 bar) 1/2" NPT/ blind stopper | P | |
| Flange 2½" 600 lb RF, ASME B16.5/316/316L | 9 0 | L 2 B | | | | Stainless steel double chamber/IP66/IP68 (0.2 bar) M20 x 1.5/blind stopper | Q | |
| Flange DN 50 PN 40 Form D, EN 1092-1/316/316L ²⁴⁾ | 9 0 | L 2 C | | | | Stainless steel double chamber/IP66/IP68 (0.2 bar) 1/2" NPT/blind stopper | R | |
| Flange 2½" 1 500 lb RF, ASME B16.5/316/316L | 9 0 | L 2 D | | | | Aluminum/IP66/IP68 (0.2 bar) M20 x 1.5/cable gland stainless steel | S | |
| Flange 2" 600 lb RF, ASME B16.5/316L (Norsok) ³⁴⁾³⁵⁾ | 9 0 | L 2 E | | | | Aluminum double chamber/IP66/IP68 (0.2 bar) M20 x 1.5/cable gland stainless steel | T | |
| Flange 3" 1500lb RJF, ASME B16.5/ 316/316L ³²⁾ | 9 0 | L 2 F | | | | Stainless steel (precision casting) 316L/IP66/IP68 (0.2 bar) M20 x 1.5/cable gland stainless steel | U | |
| Thread G 1" (DIN 3852-A) PN 100/316L | 9 0 | L 3 C | | | | Stainless steel (electropolished) 316L/IP66/IP68 (0.2 bar) M20 x 1.5/cable gland stainless steel | V | |
| Thread 1" NPT, ASME B1.20.1/PN 100/316L | 9 0 | L 3 D | | | | Aluminum single chamber/IP66/IP68 (0.2 bar) M20 x 1.5/cable gland brass nickel-plated | W | |
| Thread G 1½" (DIN 3852-A) PN 100/316L | 9 0 | L 3 E | | | | Aluminum double chamber/IP66/IP68 (0.2 bar) M20 x 1.5/cable gland brass nickel-plated | X | |
| Thread 1½" NPT, ASME B1.20.1/PN 100/316L | 9 0 | L 3 F | | | | Stainless steel single chamber (precision casting)/IP66/IP68 (0.2 bar) M20 x 1.5/cable gland brass nickel-plated | Y | |
| Thread 2" NPT, ASME B1.20.1/PN 100/316L | 9 0 | L 3 G | | | | Stainless steel double chamber/IP66/IP68 (0.2 bar) M20 x 1.5/cable gland brass nickel-plated | J | |
| Thread G ¾ PN100, DIN 3852-A/316L ³¹⁾ | 9 0 | L 3 H | | | | Remote stainless steel single chamber housing, electropolished/IP66/IP67 with cable outlet IP68 (electronics separated by cable); M20 x 1.5/blind plug ⁶⁾ | Z | Q 2 A |
| Thread ¾ NPT PN100, ASME B1.20.1/31 ³¹⁾ | 9 0 | L 3 J | | | | Remote plastic single chamber housing /IP66/IP67 with cable outlet IP68 (electronics separated by cable); M20 x 1.5/blind plug ⁶⁾ | Z | Q 2 B |
| Electronics | | | | | | | | |
| Two-wire 4 ... 20 mA/HART | 0 | | | | | | | |
| Four-wire Modbus ⁵⁾⁶⁾⁸⁾ | 1 | | | | | | | |
| Two-wire 4 ... 20 mA/HART with SIL qualification ⁵⁾ | 2 | | | | | | | |
| Four-wire 4 ... 20 mA/HART; 90 ... 253 V AC; 50/60 Hz ⁵⁾⁶⁾⁸⁾ | 3 | | | | | | | |
| Four-wire 4 ... 20 mA/HART; 9.6 ... 48 V DC; 20 ... 42 V AC ⁵⁾⁶⁾⁸⁾ | 4 | | | | | | | |
| PROFIBUS PA ⁵⁾ | 5 | | | | | | | |
| FOUNDATION Fieldbus ⁵⁾ | 6 | | | | | | | |
| Seal/Second line of defense/ Process temperature | | | | | | | | |
| Ceramic-graphite/with glass seal/ -196 ... +280 °C (-321 ... +536 °F) | A | | | | | | | |
| Ceramic-graphite/with glass seal/ -196 ... +450 °C (-321 ... +842 °F) | B | | | | | | | |
| Ceramic-graphite/with glass seal/ -196 ... +400 °C (-321 ... +752 °F) ²¹⁾ | C | | | | | | | |
| PEEK-FFKM (Kalrez 6375) /with glass seal/ -20...+250 °C (-4 ... +482 °F) ²¹⁾ | D | | | | | | | |

Level measurement

Continuous level measurement
Guided wave radar transmitters

SITRANS LG series

Selection and ordering data

Article No.

Article No.

SITRANS LG270 Guided radar level transmitter

Continuous, contact, 60 m (197 ft) range.
Monitors level and interface in liquids in extreme environments.

Lengths

Rod ø 16 mm/316L

| | |
|--|---|
| 300 mm (11.81 inch) ²⁵⁾ | 0 |
| 500 mm (19.69 inch) ²⁵⁾ | 1 |
| 501 ... 1 000 mm (19.72 ... 39.37 inch) ²⁵⁾ | 2 |
| 1 001 ... 2 000 mm (39.41 ... 78.74 inch) ²⁵⁾ | 3 |
| 2 001 ... 3 000 mm (78.78 ... 118.11 inch) ²⁵⁾ | 4 |
| 3 001 ... 4 000 mm (118.15 ... 157.48 inch) ²⁵⁾ | 5 |
| 4 001 ... 5 000 mm (157.52 ... 196.85 inch) ²⁵⁾ | 6 |
| 5 001 ... 6 000 mm (196.89 ... 236.22 inch) ²⁵⁾ | 7 |

Rod ø 16 mm/C22

| | | |
|--|---|-------|
| 501 ... 1 000 mm (19.72 ... 39.37 inch) ²⁵⁾ | 9 | R 1 A |
| 1 001 ... 2 000 mm (39.41 ... 78.74 inch) ²⁵⁾ | 9 | R 1 B |
| 2 001 ... 3 000 mm (78.78 ... 118.11 inch) ²⁵⁾ | 9 | R 1 C |
| 3 001 ... 4 000 mm (118.15 ... 157.48 inch) ²⁵⁾ | 9 | R 1 D |
| 4 001 ... 5 000 mm (157.52 ... 196.85 inch) ²⁵⁾ | 9 | R 1 E |
| 5 001 ... 6 000 mm (196.89 ... 236.22 inch) ²⁵⁾ | 9 | R 1 F |

Rod ø 8 mm/316L

| | | |
|---|---|-------|
| 300 ... 1 000 mm (11.81 ... 39.37 inch) | 9 | R 1 H |
| 1 001 ... 2 000 mm (39.41 ... 78.74 inch) | 9 | R 1 J |
| 2 001 ... 3 000 mm (78.78 ... 118.11 inch) | 9 | R 1 K |
| 3 001 ... 4 000 mm (118.15 ... 157.48 inch) | 9 | R 1 L |
| 4 001 ... 5 000 mm (157.52 ... 196.85 inch) | 9 | R 1 M |
| 5 001 ... 6 000 mm (196.89 ... 236.22 inch) | 9 | R 1 N |

Cable lengths ø 2 or 4 mm/316L

| | | |
|---|---|-------|
| 501 ... 1 000 mm (19.72 ... 39.37 inch) | 9 | R 2 E |
| 1 000 ... 5 000 mm (39.37 ... 196.85 inch) | 9 | R 2 F |
| 5 001 ... 10 000 mm (196.89 ... 393.70 inch) | 9 | R 2 G |
| 10 001 ... 15 000 mm (393.74 ... 590.55 inch) | 9 | R 2 H |
| 15 001 ... 20 000 mm (590.59 ... 787.40 inch) | 9 | R 2 J |
| 20 001 ... 25 000 mm (787.44 ... 984.25 inch) | 9 | R 2 K |
| 25 001 ... 30 000 mm (984.29 ... 1 181.10 inch) | 9 | R 2 L |
| 30 001 ... 35 000 mm (1 181.14 ... 1 377.95 inch) | 9 | R 2 M |
| 35 001 ... 40 000 mm (1 377.99 ... 1 574.80 inch) | 9 | R 2 N |
| 40 001 ... 45 000 mm (1 574.84 ... 1 771.65 inch) | 9 | R 2 P |
| 45 001 ... 50 000 mm (1 771.69 ... 1 968.50 inch) | 9 | R 2 Q |
| 50 001 ... 55 000 mm (1 968.54 ... 2 165.35 inch) | 9 | R 2 R |
| 55 001 ... 60 000 mm (2 165.39 ... 2 362.20 inch) | 9 | R 2 S |

SITRANS LG270 Guided radar level transmitter

Continuous, contact, 60 m (197 ft) range.
Monitors level and interface in liquids in extreme environments.

Cable lengths ø 4 mm/ C22

| | | |
|---|---|-------|
| 501 ... 1 000 mm (19.72 ... 39.37 inch) | 9 | R 4 A |
| 1 000 ... 5 000 mm (39.37 ... 196.85 inch) | 9 | R 4 B |
| 5 001 ... 10 000 mm (196.89 ... 393.70 inch) | 9 | R 4 C |
| 10 001 ... 15 000 mm (393.74 ... 590.55 inch) | 9 | R 4 D |
| 15 001 ... 20 000 mm (590.59 ... 787.40 inch) | 9 | R 4 E |
| 20 001 ... 25 000 mm (787.44 ... 984.25 inch) | 9 | R 4 F |
| 25 001 ... 30 000 mm (984.29 ... 1 181.10 inch) | 9 | R 4 G |
| 30 001 ... 35 000 mm (1 181.14 ... 1 377.95 inch) | 9 | R 4 H |
| 35 001 ... 40 000 mm (1 377.99 ... 1 574.80 inch) | 9 | R 4 J |
| 40 001 ... 45 000 mm (1 574.84 ... 1 771.65 inch) | 9 | R 4 K |
| 45 001 ... 50 000 mm (1 771.69 ... 1 968.50 inch) | 9 | R 4 L |
| 50 001 ... 55 000 mm (1 968.54 ... 2 165.35 inch) | 9 | R 4 M |
| 55 001 ... 60 000 mm (2 165.39 ... 2 362.20 inch) | 9 | R 4 N |

Coax ø 42.2 mm/316L

| | | |
|---|---|-------|
| 300 ... 1 000 mm (11.81 ... 39.37 inch) ²⁵⁾ | 9 | R 3 G |
| 1 001 ... 2 000 mm (39.41 ... 78.74 inch) ²⁵⁾²⁶⁾ | 9 | R 3 H |
| 2 001 ... 3 000 mm (78.78 ... 118.11 inch) ²⁵⁾ | 9 | R 3 J |
| 3 001 ... 4 000 mm (118.15 ... 157.48 inch) ²⁵⁾ | 9 | R 3 K |
| 4 001 ... 5 000 mm (157.52 ... 196.85 inch) ²⁵⁾ | 9 | R 3 L |
| 5 001 ... 6 000 mm (196.89 ... 236.22 inch) ²⁵⁾ | 9 | R 3 M |

Coax ø 42.2 mm/C22

| | | |
|---|---|-------|
| 300 ... 1 000 mm (11.81 ... 39.37 inch) ²⁵⁾ | 9 | R 3 Q |
| 1 001 ... 2 000 mm (39.41 ... 78.74 inch) ²⁵⁾²⁶⁾ | 9 | R 3 R |
| 2 001 ... 3 000 mm (78.78 ... 118.11 inch) ²⁵⁾ | 9 | R 3 S |
| 3 001 ... 4 000 mm (118.15 ... 157.48 inch) ²⁵⁾ | 9 | R 3 T |
| 4 001 ... 5 000 mm (157.52 ... 196.85 inch) ²⁵⁾ | 9 | R 3 U |
| 5 001 ... 6 000 mm (196.89 ... 236.22 inch) ²⁵⁾ | 9 | R 3 V |

Coax ø 21.3 mm/316L

| | | |
|---|---|-------|
| 300 ... 1 000 mm (11.81 ... 39.37 inch) | 9 | R 5 A |
| 1 001 ... 2 000 mm (39.41 ... 78.74 inch) | 9 | R 5 B |
| 2 001 ... 3 000 mm (78.78 ... 118.11 inch) | 9 | R 5 C |
| 3 001 ... 4 000 mm (118.15 ... 157.48 inch) | 9 | R 5 D |
| 4 001 ... 5 000 mm (157.52 ... 196.85 inch) | 9 | R 5 E |
| 5 001 ... 6 000 mm (196.89 ... 236.22 inch) | 9 | R 5 F |

| Selection and ordering data | Order code | Order code |
|--|------------|---|
| <i>Further designs (mandatory)</i> | | <i>Further designs (optional)</i> |
| Please add "-Z" to Article No. and specify Order code(s). | | Please add "-Z" to Article No. and specify Order code(s). |
| Supplementary electronics | | Enter the total insertion length in plain text description |
| Without | A00 | Y01 |
| Additional current output 4 ... 20 mA ⁶⁾ | A01 | Y02 |
| Dimensions centering weight (diameter/height) | | Y02 rigid part is 100 mm, only applicable for cable versions |
| Without | B00 | Reference probe G length of reference distance = 260 mm/10.24 inches (note blanking 450 mm required with min. probe 1 000 mm) |
| ø 40/30 mm | B01 | Y05 |
| ø 45/30 mm (for 2 inch tubes) | B02 | Reference probe G length of reference distance = 500 mm/19.69 inches (note blanking 690 mm required with min. probe 1 250 mm) |
| ø 75/30 mm (for 3 inch tubes) | B03 | Y06 |
| ø 95/30 mm (for 4 inch tubes) | B04 | Reference probe G length of reference distance = 750 mm/29.53 inches (note blanking 940 mm required with min. probe 1 500 mm) |
| ø 40 mm/30 mm | B05 | Y07 |
| ø 1.57 inch/1.18 inch (for 2 inch Schedule 160) | | Remote electronic cable lengths: 2 m (6.6 ft). Only available with Housing options Q2A and Q2B |
| ø 45 mm/30 mm (for 2 inch tubes) | B06 | Y10 |
| ø 1.77 inch/1.18 inch (for 2 inch Schedule 40/80) | | Remote electronic cable lengths: 5 m (16.4 ft). Only available with Housing options Q2A and Q2B |
| ø 75 mm/30 mm (for 3 inch tubes) | B07 | Y11 |
| ø 2.95 inch/1.18 inch (for 3 inch Schedule 10/40) | | Remote electronic cable lengths: 10 m (32.8 ft). Only available with Housing options Q2A and Q2B |
| ø 95 mm/30 mm (for 4 inch tubes) | B08 | Y12 |
| ø 3.74 inch/1.18 inch (for 4 inch Schedule 80) | | Customer specific adjustment (unit value, 100 % distance from seal, 0 % distance from seal) |
| Rod mounted | | Y20 |
| Without Rod, applicable for coax or cable probe types only | C00 | Cleaning included certificate: oil, grease and silicone free |
| Mounted | C01 | W01 |
| Not mounted | C02 | Identification Label (measurement loop) stainless steel, 40 characters max, add in plain text. To add more than one line use a coma "," for line break. |
| Indicating/adjustment module | | Y17 |
| Without | E00 | Identification Label (measurement loop) foil, 40 characters max, add in plain text. To add more than one line use a coma "," for line break. |
| Mounted | E01 | Y18 |
| Laterally mounted | E02 | Material Inspection certificate 3.1 of EN 10204 |
| Language of display | | C05 |
| German | L00 | 3.1-Inspection Certificate for instrument (EN 10204) ²⁷⁾ |
| English | L01 | C12 |
| French | L02 | Inspection certificate 3.1 (EN 10204, NACE MR 0175) - material ²⁷⁾ |
| Dutch | L03 | D07 |
| Italian | L04 | Note: 316L probes include NACE MR 0175 and MR 0103, non 316L probes include MR 0175 only and plated flange designs are not available with NACE certificate. |
| Spanish | L05 | 3.1-Inspection Certificate for instrument with test data (EN 10204) ²⁷⁾ |
| Portuguese | L06 | C25 |
| Russian | L07 | 2.2-Factory certificate for material (EN 10204) ²⁷⁾ |
| Chinese | L08 | C15 |
| Japanese | L09 | Quality and test plan ²⁷⁾ |
| No language pre-set | L10 | C26 |
| Operating instructions | | Dye penetration test, results confirmed via a 3.1 certificate/instrument (EN10204) ²⁷⁾ |
| German | M00 | C13 |
| English | M01 | X-ray test + 3.1 certificate/instrument ²⁷⁾ |
| French | M02 | C14 |
| Spanish | M03 | Positive material identification test + 3.1 certificate/instrument ²⁷⁾ |
| | | C16 |
| | | Roughness test + 3.1 certificate/instrument ²⁷⁾ |
| | | C18 |
| | | Pressure test + 3.1 certificate/instrument ²⁷⁾ |
| | | C31 |
| | | Helium leak test + 3.1 certificate/instrument ²⁷⁾ |
| | | C32 |
| | | Pressure test according to Norsok + 3.1 certificate/instrument ²⁷⁾³³⁾ |
| | | C61 |
| | | 5 point calibration certificate (min. length 500 mm) ²⁷⁾ |
| | | C62 |
| | | Pressure test (acc. to ASME B31.1), incl. 3.1 Inspection certificate ²⁸⁾ |
| | | C63 |
| | | Certificate: Approval for steam boiler according to EN 12952-11, EN 12953-g ²⁹⁾ |
| | | C70 |

Level measurement

Continuous level measurement
Guided wave radar transmitters

SITRANS LG series

Selection and ordering data

Article No.

Operating Instructions

All literature is available to download for free, in a range of languages, at

<http://www.siemens.com/processinstrumentation/documentation>

Accessories

| | |
|---|--------------------------|
| SITRANS LG series/SITRANS RD150 sensor display module | A5E34143449 |
| SITRANS LG, two-wire 4 ... 20 mA/HART electronic | A5E35637821 |
| SITRANS LG, USB communicator | A5E35192015 |
| SITRANS LG, Mounting eye M12 x 20 | PBD:51041448 |
| SITRANS LG, Mounting spring | PBD:51041449 |
| Siemens Intrinsically Safe Barrier (DC powered), ATEX II 1 G EEx ia | 7NG4124-0AA00 |
| SITRANS RD100, loop powered display - see Chapter 7 | 7ML5741-.....- |
| SITRANS RD150, remote digital display for 4 ... 20 mA and HART devices - see Chapter 7 | 7ML5742-.....-... |
| SITRANS RD200, universal input display with Modbus conversion - see Chapter 7 | 7ML5740-.....- |
| SITRANS RD300, dual line display with totalizer and linearization curve and Modbus conversion - see Chapter 7 | 7ML5744-.....- |
| For applicable back up point level switch - see point level measurement section | |

Note: some configuration options are not available.

For restriction information see the online PIA configuration tool.

Note: Please consult manual for further details.

- 1) Not available with Version/Material options E, F, G, J, and K.
- 2) Available only with certain Electronic options.
- 3) Not available with Seal/Process temperature option D.
- 4) Not available with Stainless Steel (electropolished) Housing/Protection/Cable options and certain glands.
- 5) Available only with Supplementary electronic option A00.
- 6) Not available with Indicating/adjusting module E02.
- 7) Not available with Plastic and Stainless Steel (electropolished) Housing/Protection/Cable options and certain glands.
- 8) Available only with Double chamber, Metallic Housing/Protection/Cable options and certain glands.
- 9) Available only with Version/Material options A, B, C, D, and H.
- 10) Not available with Remote and Stainless Steel (electropolished) Housing/Protection/Cable options and certain glands.
- 11) Available only with Single chamber, Aluminum and Stainless steel (precision casting) Housing/Protection/Cable options.
- 12) Available only with Housing/Protection/Cable options N, P, V, and Q2A.
- 13) Not available with Housing/Protection/Cable options W, X, Y, and J.
- 14) Available only with Housing/Protection/Cable options C, E, L, Q.
- 15) Not available with Seal/Process temperature option C.
- 16) Available only with Dimensions centering weight option B00.
- 17) Available only with Rod mounted option C00.
- 18) Not available with Dimensions centering weight option B00.
- 19) Not available with Rod mounted option C00.
- 20) Not available with Seal/Process temperature options C and D.
- 21) Not available with Remote Housing/Protection/Cable options.
- 22) Not available with Seal/Process temperature options B and D.
- 23) Available only with Seal/Process temperature option D.
- 24) Available only with Seal/Process temperature options A, B, and C.
- 25) Not available with Order code Y02.
- 26) Accuracy is application dependent, please consult factory.
- 27) Listed Certificates are not available with all configurations, please contact factory for more information.
- 28) Available only with ASME Process fitting/Material options.
- 29) Available with Version/Material options G, L, M and Electronic options 2 and 6.
- 30) Available only with Alloy C22 Process fitting/Material options.
- 31) Available only with Version/Material option M.
- 32) Available only with some Version/Material options.
- 33) Available only with Norsok Process fitting options.
- 34) Available only with Seal/Second line of defense/Process temperature options A and B.
- 35) Available only with 316L probe Version/material options. Nace not available with coated, plated, or hygienic connections.

| Selection and ordering data | Article No. | Article No. | |
|---|-------------------------|--|-------------------------|
| SITRANS LG Remote Interface Provides remote display and configuration for SITRANS LG series guided radar level transmitters. ↗ Click on the Article No. for the online configuration in the PIA Life Cycle Portal. | 7ML5840- - - - - - 0 | SITRANS LG Replacement Probes For use with SITRANS LG series guided radar level transmitters. ↗ Click on the Article No. for the online configuration in the PIA Life Cycle Portal. | 7ML5841- - - - - - 0 |
| Note: for installation of remote display, 7ML5840, with LG two chamber housing options, contact PVC | | Instrument LG240 ⁴⁾ 0 LG250 ⁶⁾ 1 LG260 ⁷⁾ 2 LG270 ⁹⁾¹⁰⁾ 3 | |
| Approval For Ex-free area 0 A ATEX II 1G, 2G, Ex ia IIC T6 Ga, Gb 0 C ATEX II 2G, Ex d IIC T6 Gb ¹⁾ 0 E IEC Ex ia IIC T6 Ga, Gb 0 F IEC Ex d IIC T6 Gb ¹⁾ 0 G cCSA _{US} (NI) Class I, Div. 2, Groups A, B, C, D; (DIP) Class II, III, Div. 1, Groups E, F, G 0 H cCSA _{US} (IS) Class I, II, III, Div. 1, Groups A, B, C, D, E, F, G 0 J cCSA _{US} (XP) Class I, Div. 1, Groups A, B, C, D ¹⁾ 0 K INMETRO Ex ia IIC T6 Ga, Gb 0 L INMETRO Ex d IIC T6 Gb ¹⁾ 0 M Shipping Approval (DNV/GL) ⁶⁾ 0 N ATEX II 1G, 2G Ex ia IIC T6 Ga, Gb + Ship approval 0 P ATEX II 2G Ex db IIC T6 Gb + Ship approval ¹⁾ 0 Q IEC Ex ia IIC T6 Ga, Gb + Ship approval 0 R IEC Ex db IIC T6 Gb + Ship approval ¹⁾ 0 S cCSA _{US} (IS) Class I, II, III, Div. 1, Groups A, B, C, D, E, F, G + Ship approval 0 T cCSA _{US} (XP) Class I, Div. 1, Groups A, B, C, D + Ship approval ¹⁾ 0 U | | Probe Type³⁾ Exchangeable cable ø 2 mm with gravity weight/316 ¹⁾¹¹⁾ A A Exchangeable cable ø 2 mm center weight/316 ²⁾¹¹⁾ A C Exchangeable cable ø 4 mm without weight/316 ¹⁾¹¹⁾ A D Exchangeable cable ø 4 mm with gravity weight/316 ¹⁾¹¹⁾ A E Exchangeable cable ø 4 mm with center weight/316 ²⁾¹¹⁾ A G Exchangeable cable ø 6 mm with gravity weight/316 ¹⁾⁸⁾¹¹⁾ A H Exchangeable rod ø 8 mm/316L ¹⁾ A P Exchangeable rod ø 8 mm/1.4435 (acc. to Basle Standard) ¹⁾ A Q Exchangeable rod ø 12 mm/316L ¹⁾ A U Exchangeable rod ø 16 mm/316L ¹⁾ A W Exchangeable coated cable ø4 mm with uncoated centering weight / PFA and 316 ¹⁾¹²⁾ B A | |
| Electronics Digital (I ² C communication) A | | Process fitting Thread less than or equal to 1½ inch 0 Thread greater than or equal to 2 inch 1 Flange less than DN 50 or 2 inch 2 Flange greater or equal to DN 50 or 2 inch or hygienic fitting (not for safety ingold 25 x 46 mm) 3 | |
| Housing Plastic ²⁾⁴⁾ 0 Aluminum ³⁾⁵⁾ 1 Stainless Steel (precision casting) ³⁾⁵⁾ 2 | | Dimension centering weight Without 0 ø 40 mm/30 mm 1 ø 45 mm/30 mm (for 2 inch tubes) 2 ø 75 mm/30 mm (for 3 inch tubes) 3 ø 95 mm/30 mm (for 4 inch tubes) 4 ø 1.57 inch/1.18 inch (for 2 inch Schedule 160) 5 ø 1.77 inch/1.18 inch (for 2 inch Schedule 40/80) 6 ø 2.95 inch/1.18 inch (for 3 inch Schedule 10/40) 7 ø 3.74 inch/1.18 inch (for 4 inch Schedule 80) 8 | |
| Housing protection IP66/IP67 NEMA 4X 0 IP66/IP68 NEMA 6P (0.2 bar) 1 | | Certificates Without 0 2.2 Material certificate 1 3.1 Material certificate 2 | |
| Cable entry M20 x 1.5/ Blind plug 3 ½" NPT/ Blind plug 5 | | | |
| Display Without A Mounted B | | | |
| Mounting For wall mounting with Aluminum or stainless steel housing A For carrier rail and wall mounting with plastic housing B For carrier rail with Aluminum or stainless steel housing C For tube mounting (29 ... 60 mm) including mounting material D | | | |
| Certificates None 0 3.1 Certificate/Instrument with test data 1 Quality and Test plan 2 | | | |

¹⁾ Available only with Housing options 1 and 2.

²⁾ Available only with Housing option 0.

³⁾ Available only with Housing option 1.

⁴⁾ Available only with Mounting options B and D.

⁵⁾ Not available with Mounting option B.

⁶⁾ Shipping approval is only available with housing options 0 and 1.

Level measurement

Continuous level measurement
Guided wave radar transmitters

SITRANS LG series

Selection and ordering data

Article No.

Article No.

SITRANS LG Replacement Probes

7ML5841-

SITRANS LG Replacement Probes

7ML5841-

For use with SITRANS LG series guided radar level transmitters.

For use with SITRANS LG series guided radar level transmitters.

Lengths

Rod ø 8 mm

300 ... 1 000 mm (11.81 ... 39.37 inch)
1 001 ... 2 000 mm (39.41 ... 78.74 inch)
2 001 ... 3 000 mm (78.78 ... 118.11 inch)
3 001 ... 4 000 mm (118.15 ... 157.48 inch)
4 001 ... 5 000 mm (157.52 ... 196.85 inch)
5 001 ... 6 000 mm (196.89 ... 236.22 inch)

AA
AB
AC
AD
AE
AF

Rod ø 12 mm

300 ... 1 000 mm (11.81 ... 39.37 inch)
1 001 ... 2 000 mm (39.41 ... 78.74 inch)
2 001 ... 3 000 mm (78.78 ... 118.11 inch)
3 001 ... 4 000 mm (118.15 ... 157.48 inch)
4 001 ... 5 000 mm (157.52 ... 196.85 inch)
5 001 ... 6 000 mm (196.89 ... 236.22 inch)

AG
AH
AJ
AK
AL
AM

Rod ø 16 mm

300 ... 1 000 mm (11.81 ... 39.37 inch)
1 001 ... 2 000 mm (39.41 ... 78.74 inch)
2 001 ... 3 000 mm (78.78 ... 118.11 inch)
3 001 ... 4 000 mm (118.15 ... 157.48 inch)
4 001 ... 5 000 mm (157.52 ... 196.85 inch)
5 001 ... 6 000 mm (196.89 ... 236.22 inch)

AN
AP
AQ
AR
AS
AT

Cable Lengths ø 2 mm and 4 mm/316

501 ... 1 000 mm (19.72 ... 39.37 inch)
1 001 ... 5 000 mm (39.41 ... 196.85 inch)
5 000 ... 10 000 mm (196.85 ... 393.70 inch)
10 001 ... 15 000 mm (393.74 ... 590.55 inch)
15 001 ... 20 000 mm (590.59 ... 787.40 inch)
20 001 ... 25 000 mm (787.44 ... 984.25 inch)
25 001 ... 30 000 mm (984.29 ... 1 181.10 inch)
30 001 ... 35 000 mm (1 181.14 ... 1 377.95 inch)
35 001 ... 40 000 mm (1 377.99 ... 1 574.80 inch)
40 001 ... 45 000 mm (1 574.84 ... 1 771.65 inch)
45 001 ... 50 000 mm (1 771.69 ... 1 968.50 inch)
50 001 ... 55 000 mm (1 968.54 ... 2 165.35 inch)
55 001 ... 60 000 mm (2 165.39 ... 2 362.20 inch)
60 001 ... 65 000 mm (2 362.24 ... 2 559.06 inch)
65 001 ... 70 000 mm (2 559.09 ... 2 755.91 inch)
70 001 ... 75 000 mm (2 755.94 ... 2 952.76 inch)

AU
AV
AW
AX
AY
BA
BB
BC
BD
BE
BF
BG
BH
BJ
BK
BL

Cable Lengths ø 6 mm/316

501 ... 1 000 mm (19.72 ... 39.37 inch)
1 001 ... 5 000 mm (39.41 ... 196.85 inch)
5 000 ... 10 000 mm (196.89 ... 393.70 inch)
10 001 ... 15 000 mm (393.74 ... 590.55 inch)
15 001 ... 20 000 mm (590.59 ... 787.40 inch)
20 001 ... 25 000 mm (787.44 ... 984.25 inch)
25 001 ... 30 000 mm (984.29 ... 1 181.10 inch)
30 001 ... 35 000 mm (1 181.14 ... 1 377.95 inch)
35 001 ... 40 000 mm (1 377.99 ... 1 574.80 inch)
40 001 ... 45 000 mm (1 574.84 ... 1 771.65 inch)
45 001 ... 50 000 mm (1 771.69 ... 1 968.50 inch)
50 001 ... 55 000 mm (1 968.54 ... 2 165.35 inch)
55 001 ... 60 000 mm (2 165.39 ... 2 362.20 inch)
60 001 ... 65 000 mm (2 362.24 ... 2 559.06 inch)
65 001 ... 70 000 mm (2 559.09 ... 2 755.91 inch)
70 001 ... 75 000 mm (2 755.94 ... 2 952.76 inch)

BM
BN
BP
BQ
BR
BS
BT
BU
BV
BW
BX
BY
CA
CB
CC
CD
DA
DB
DC
DD
DE
DF
DG
DH

Cable Lengths ø 4 mm/316

300 ... 1 000 mm (12 ... 39.37 inch)
1 001 ... 2 000 mm (39.41 ... 78.74 inch)
2 001 ... 5 000 mm (78.77 ... 196.85 inch)
5 001 ... 10 000 mm (196.89 ... 393.70 inch)
10 001 ... 15 000 mm (393.74 ... 590.55 inch)
15 001 ... 20 000 mm (590.59 ... 787.40 inch)
20 001 ... 25 000 mm (787.44 ... 984.25 inch)
25 001 ... 32 000 mm (984.29 ... 1 259.84 inch)

Further designs

Please add "-Z" to Article No. and specify Order code(s).

Enter the total insertion length in plain text description

Total length: Enter the total length of rigid part (range 100 ... 1 000 mm LG270 limited to 100 mm) (cable versions only)

Order code

Y01

Y02

- 1) Available only with Dimension centering weight option 0.
- 2) Available only with Dimension centering weight options 1 ... 8.
- 3) All Probe types are only available with corresponding Probe lengths.
- 4) Not available with Probe type options AH, AQ, and AW.
- 5) Available only with Process fitting options 2 and 3.
- 6) Not available with Probe type options AQ and AW.
- 7) Available only with Probe type options AE, AH, and AW.
- 8) Not available with Process fitting option 2.
- 9) Available only with Probe type options AA, AC, AE, AG, and AW.
- 10) Available only with Process fitting options 0 and 3.
- 11) Not available with certificate options 1 and 2.
- 12) Available only with Dimension centering weight options 1 ... 4.

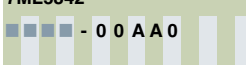

| Selection and ordering data | Article No. |
|---|---|
| SITRANS LG Spacers For use with SITRANS LG series guided radar level transmitters. Click on the Article No. for the online configuration in the PIA Life Cycle Portal. | 7ML5842-  |
| Instrument LG240 ¹⁾ LG250 ²⁾ LG260 ³⁾ LG270 ³⁾ | 0 1 2 3 |
| Version/Material Cable ø 4 mm/ PFA ⁴⁾ Rod ø 8 mm including fastening/ PEEK can be shortened ⁵⁾ Rod ø 10 mm/ PFA ⁴⁾ Rod ø 12 mm including fastening/ PEEK can be shortened ⁵⁾ Rod ø 16 mm, cable with gravity weight, including fastening/ PEEK can be shortened ⁵⁾⁷⁾ Cable ø 2 mm including fastening/ PEEK and 316L Rod ø 16 mm including fastening/ 1.4568 (AISI 631) flexible ⁸⁾ Rod ø 8 mm including fastening/ PTFE can be shortened ⁵⁾ Rod ø 12 mm including fastening/ 1.4568 (AISI 631) flexible ⁸⁾ | AA AB AC AD AE AF AG AH AG |
| Tube diameter 50 mm (2 inch) up to 100 mm (4 inch) 49.2 mm (1.9 inch) up to 56.3 mm (2.2 inch) 66.6 mm (2.6 inch) up to 84.9 mm (3.3 inch) | 1 2 3 |

- 1) Available only with Version/Material options AA and AC.
- 2) Available only with Version/Material options AB, AD, AE, AH and AJ.
- 3) Available only with Version/Material options AE and AG.
- 4) Available only with Tube Diameter option 1 and LG240.
- 5) Available only with Tube Diameter options 2 and 3 and LG250.
- 6) Available only with Tube Diameter option 1 and LG250.
- 7) Available only with Tube diameter option 1 and LG260 or LG270.
- 8) Available only with Tube Diameter options 2 and 3 and LG260 or LG270.

Level measurement

Continuous level measurement
Guided wave radar transmitters

SITRANS LG series

Characteristic curves

SITRANS LG240, Ambient temperature/process temperature, standard version

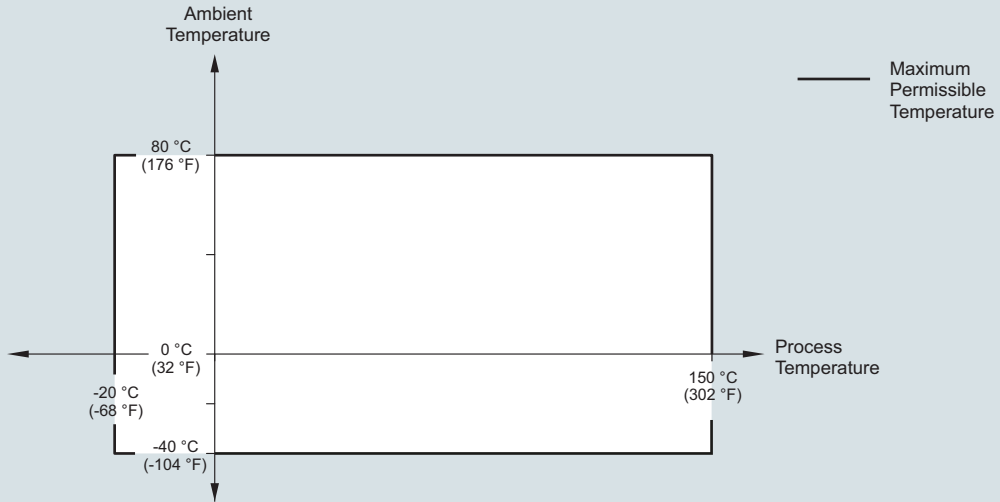

SITRANS LG240, ambient temperature/process temperature curve

Characteristic curves (continued)

SITRANS LG250, Ambient temperature/process temperature, standard version

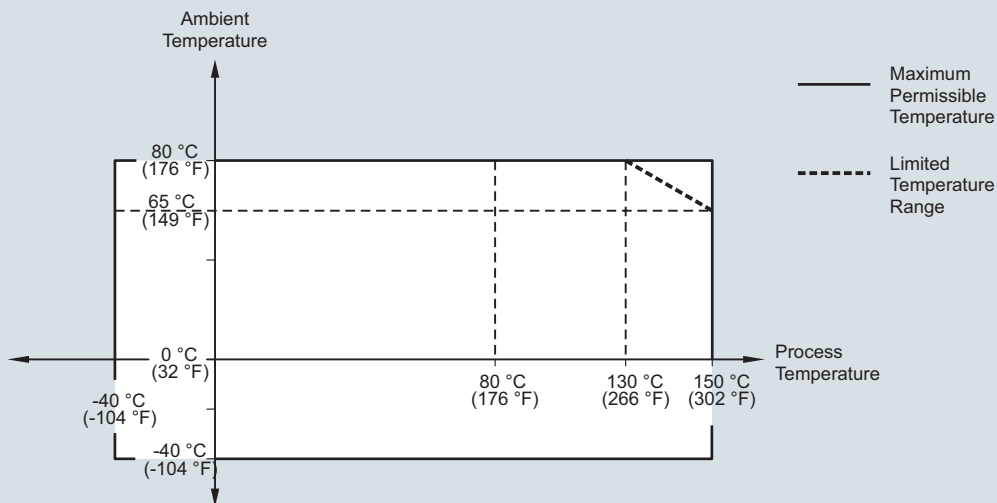

SITRANS LG250, Ambient temperature/process temperature, temperature adapter version

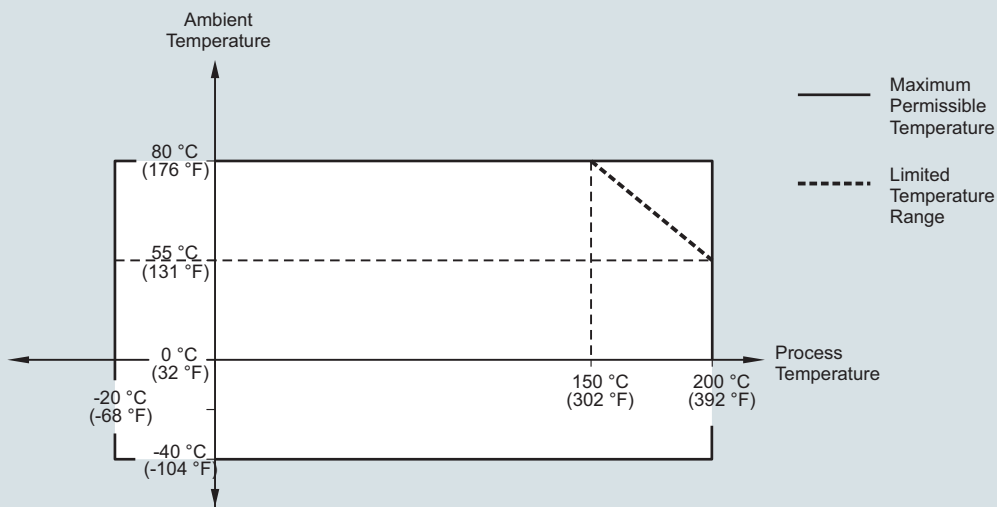

SITRANS LG250, ambient temperature/process temperature curves

Level measurement

Continuous level measurement
Guided wave radar transmitters

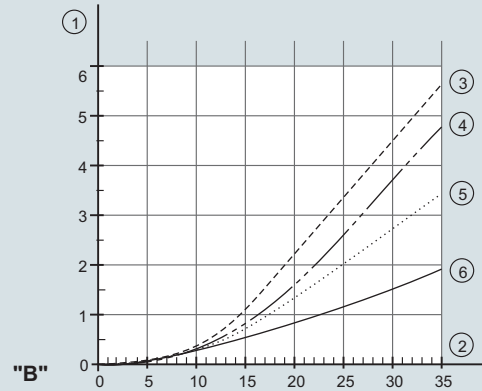
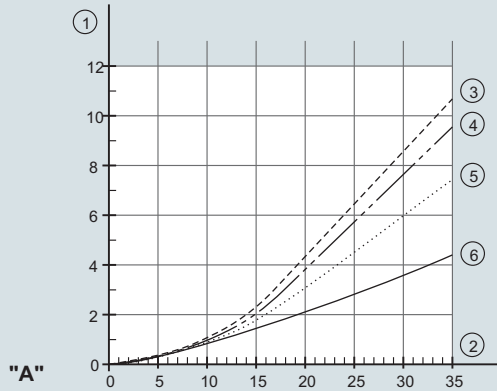
SITRANS LG series**Characteristic curves (continued)****SITRANS LG260, Maximum tensile load with cereals and plastic granules - cable: \varnothing 4 mm (0.157 inch)**

- A. Cereals
B. Plastic granules
1. Tensile force in kN (the determined value must be multiplied with safety factor 2)
2. Cable length in m
3. Vessel diameter 12 m (39.37 ft)
4. Vessel diameter 9 m (29.53 ft)
5. Vessel diameter 6 m (19.69 ft)
6. Vessel diameter 3 m (9.843 ft)

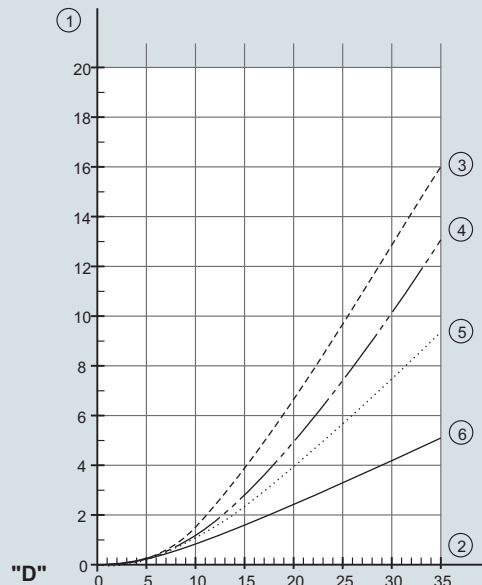
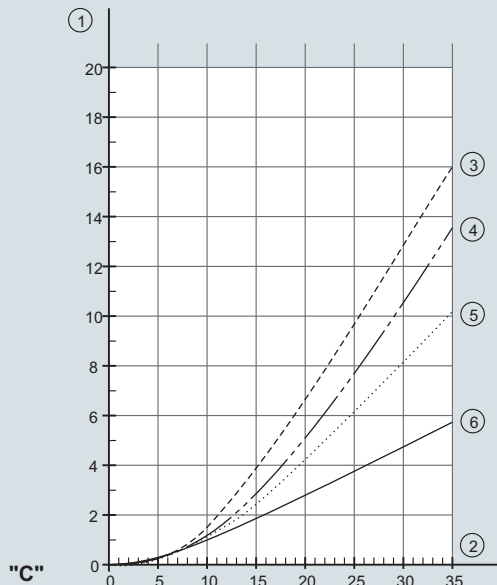
SITRANS LG260, Maximum tensile load with sand and cement - cable: \varnothing 4 mm (0.157 inch)

- C. Sand
D. Cement
1. Tensile force in kN (the determined value must be multiplied with safety factor 2)
2. Cable length in m
3. Vessel diameter 12 m (39.37 ft)
4. Vessel diameter 9 m (29.53 ft)
5. Vessel diameter 6 m (19.69 ft)
6. Vessel diameter 3 m (9.843 ft)

SITRANS LG260, maximum tensile load curves

Characteristic curves (continued)

SITRANS LG260, Ambient temperature/process temperature, standard version
 Cable version with \varnothing 4 mm (0.157 inch)
 Cable version, PA coated with \varnothing 6 mm (0.236 inch)

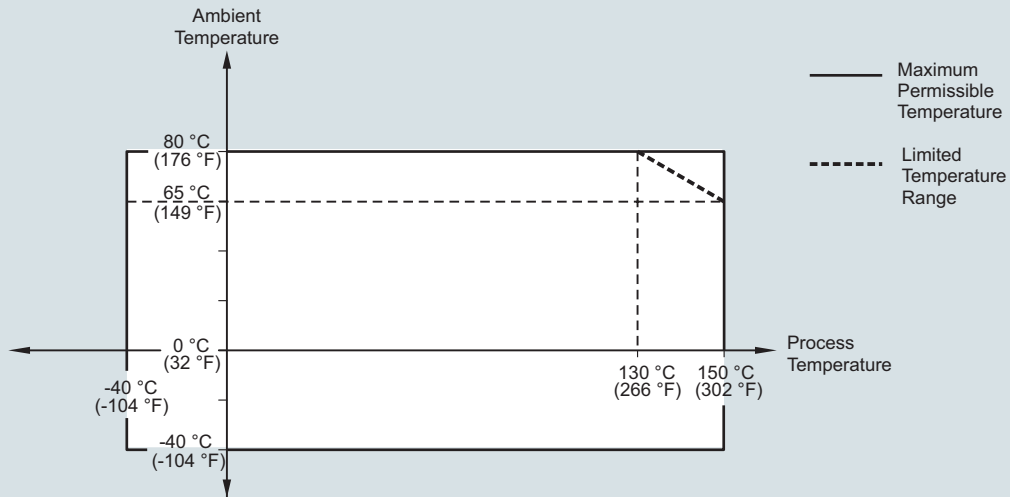

SITRANS LG260, Ambient temperature/process temperature, temperature adapter version
 Cable version with \varnothing 4 mm (0.157 inch)
 Cable version, PA coated with \varnothing 6 mm (0.236 inch)

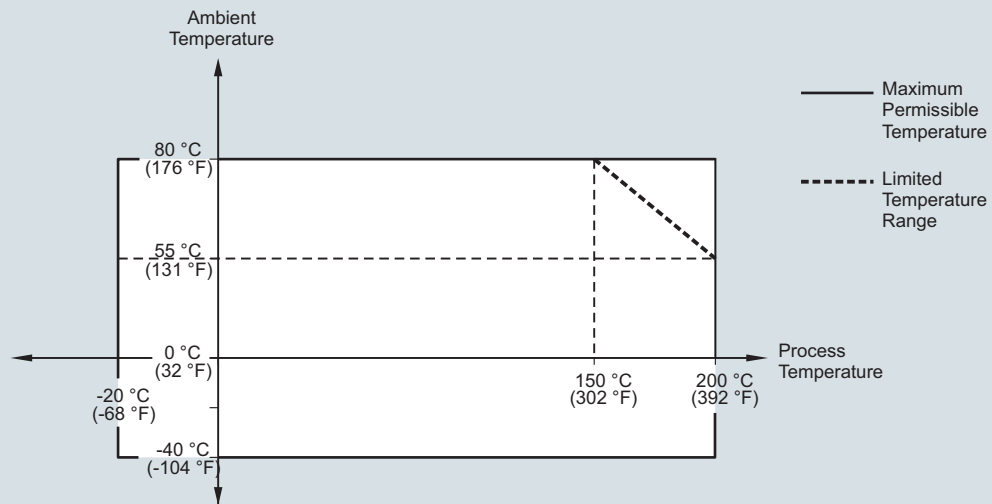

SITRANS LG260, ambient temperature/process temperature curves

Level measurement

Continuous level measurement
Guided wave radar transmitters

SITRANS LG series

Characteristic curves (continued)

SITRANS LG260, Ambient temperature/process temperature, standard version
Cable version with \varnothing 6 mm (0.236 inch)
Cable version, PA coated with \varnothing 11 mm (0.433 inch)

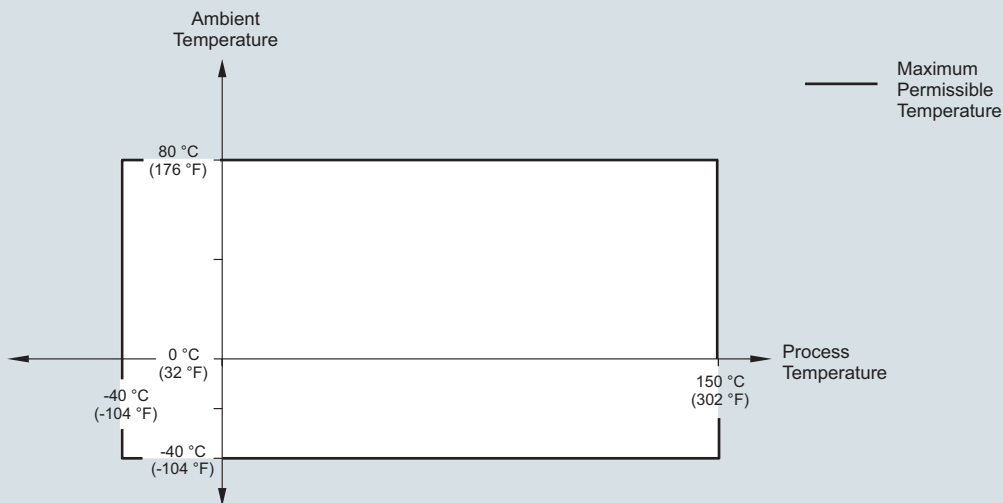

SITRANS LG260, Ambient temperature/process temperature, temperature adapter version
Cable version with \varnothing 6 mm (0.236 inch)
Cable version, PA coated with \varnothing 11 mm (0.433 inch)

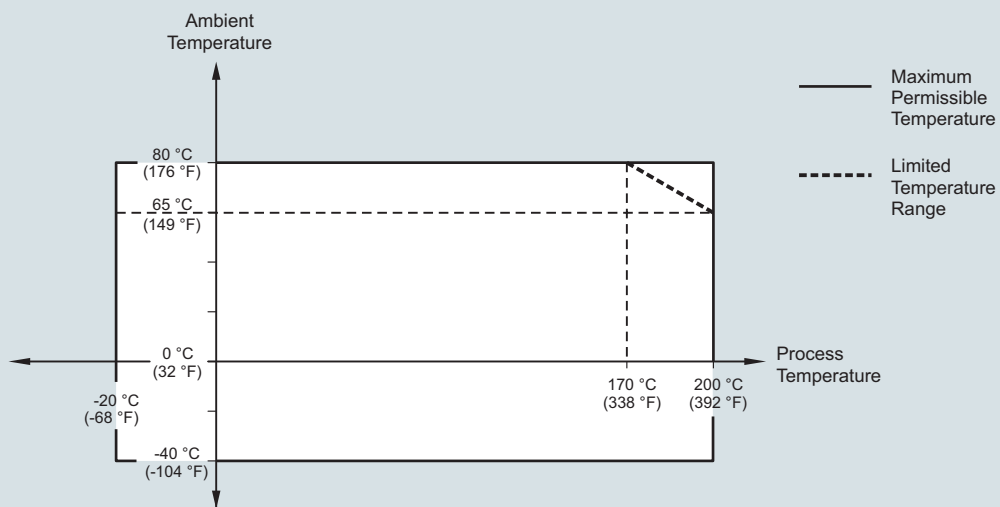

SITRANS LG260, ambient temperature/process temperature curves

Characteristic curves (continued)

SITRANS LG270, Ambient temperature/process temperature (-196 ... +280 °C/-321 ... +536 °F version)

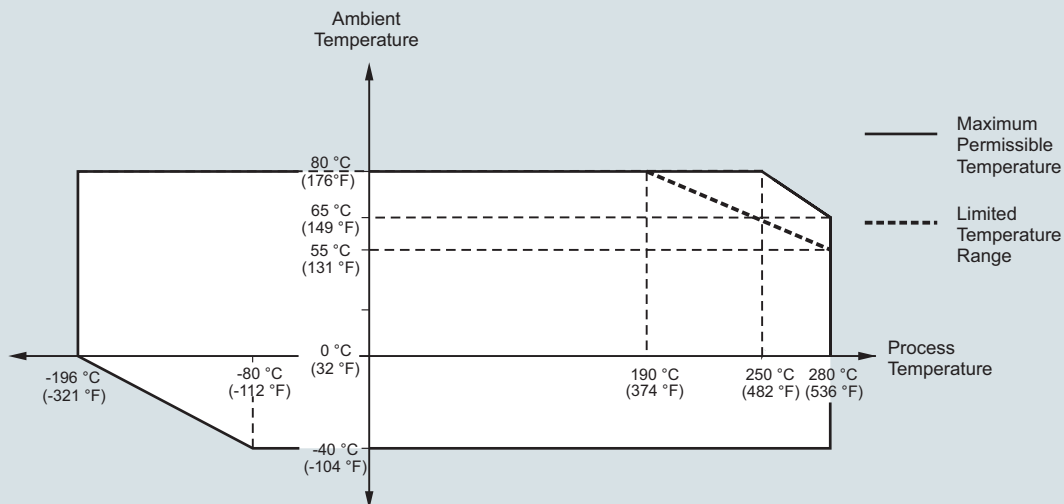

SITRANS LG270, Ambient temperature/process temperature (-196 ... +450 °C/-321 ... +842 °F version)

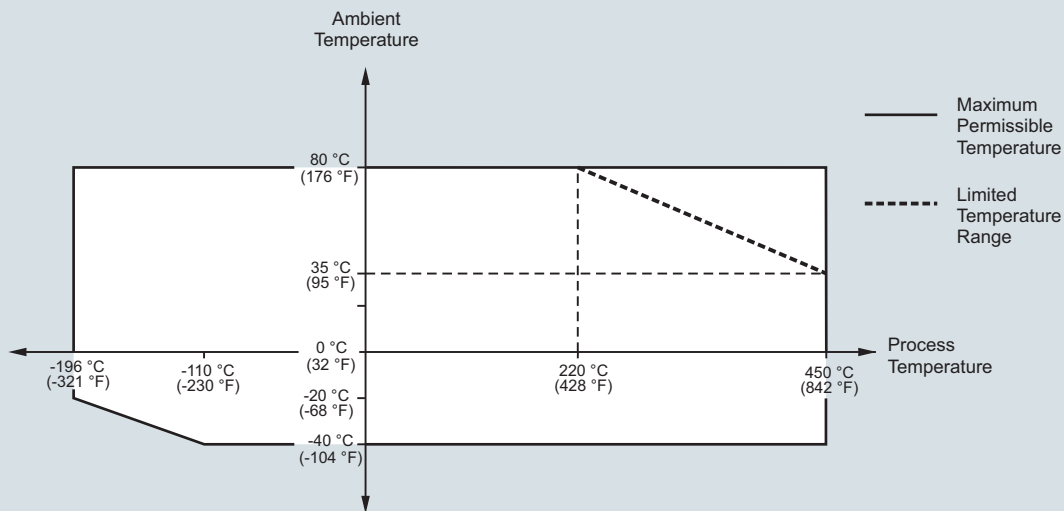

SITRANS LG270, ambient temperature/process temperature curves

Level measurement

Continuous level measurement
Guided wave radar transmitters

SITRANS LG series

Characteristic curves (continued)

SITRANS LG270, Process pressure/process temperature (-196 ... +450 °C/-321 ... +842 °F version)

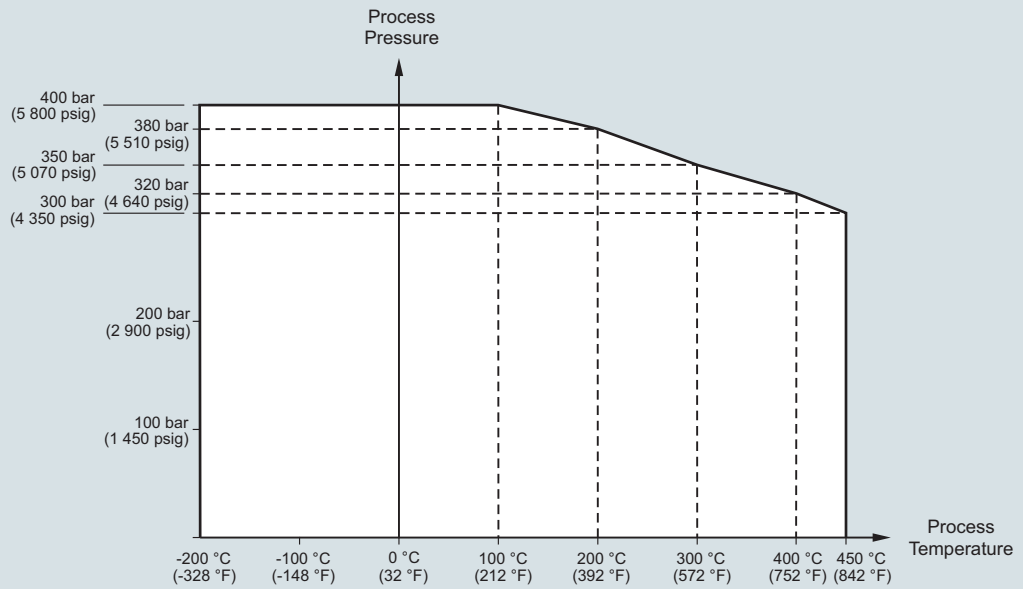

SITRANS LG270, process pressure/process temperature curve

4

Dimensional drawings

SITRANS LG Series plastic housing

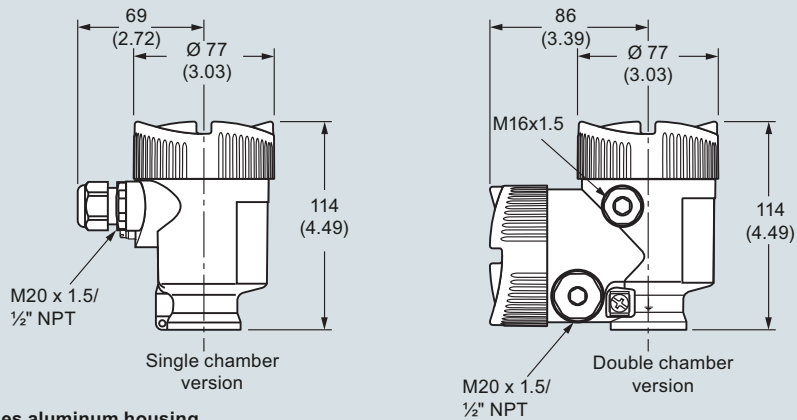

SITRANS LG Series aluminum housing

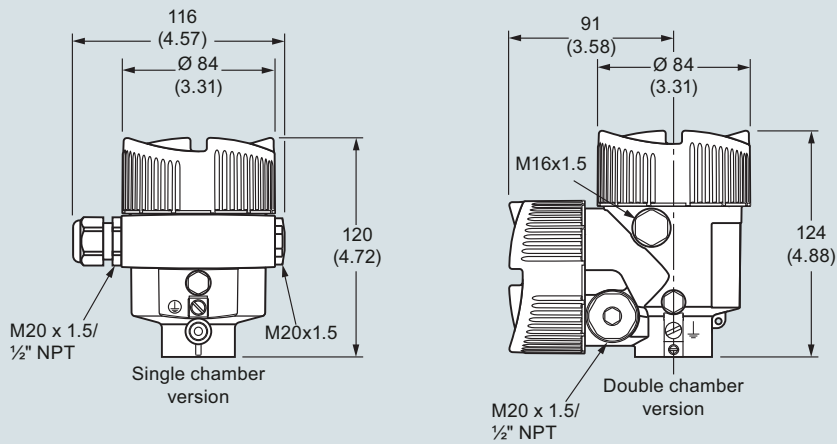

SITRANS LG Series stainless steel housing

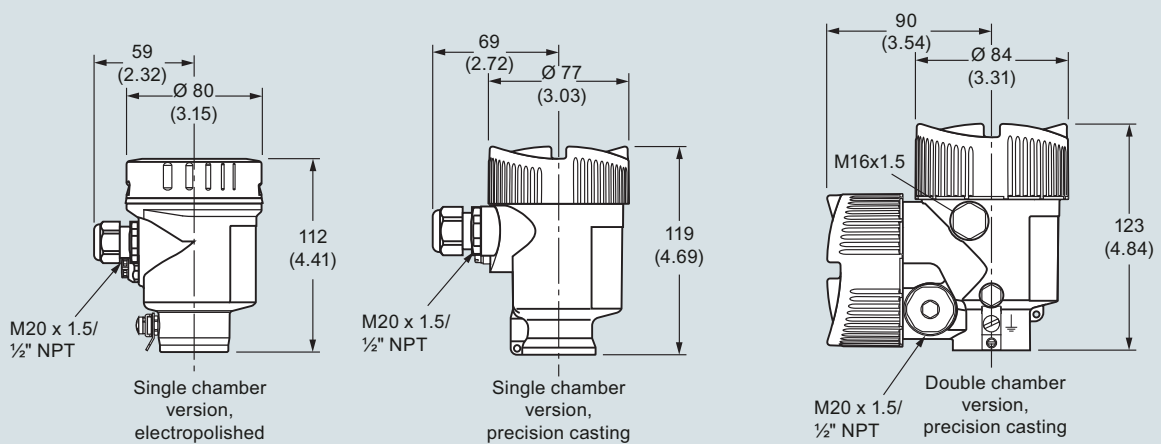

Note: For integrated display and adjustment module the housing is 9 (0.35) higher for all housing options

SITRANS LG series, dimensions in mm (inch)

Level measurement

Continuous level measurement
Guided wave radar transmitters

SITRANS LG series

Dimensional drawings (continued)

SITRANS LG240

Cable version Ø 4 (0.157), PFA coated

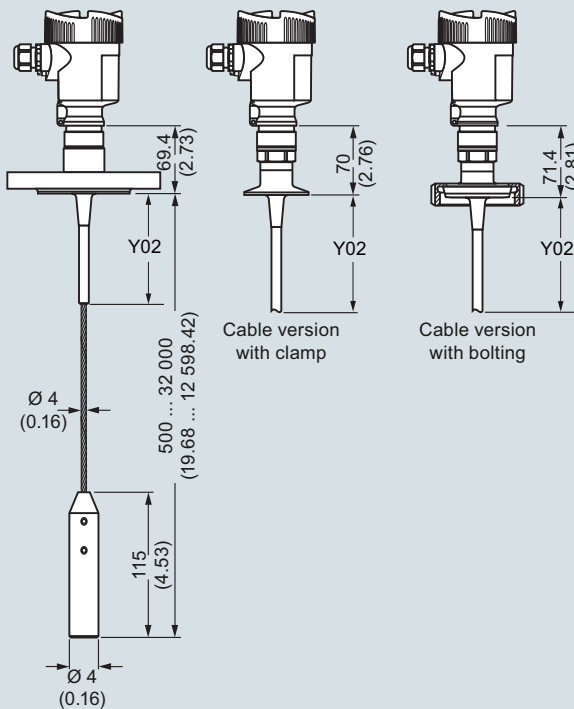

Rod version Ø 10 (0.394), PFA coated

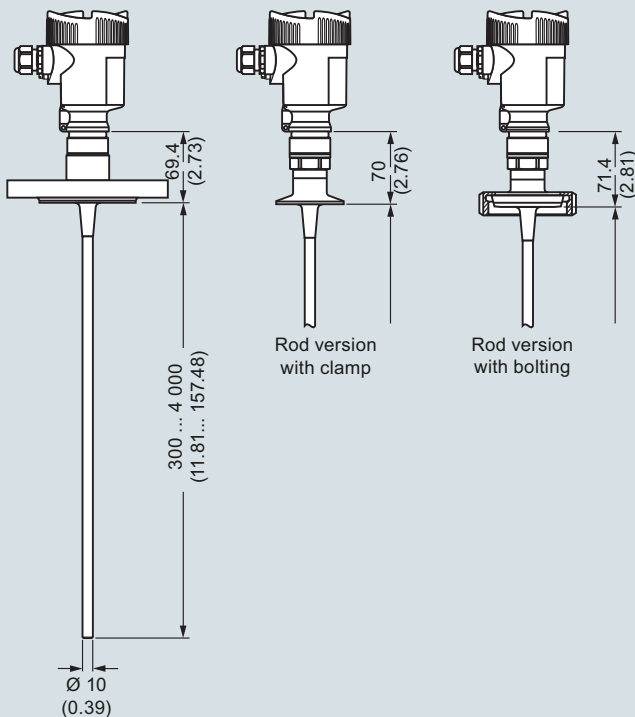

Autoclaved version

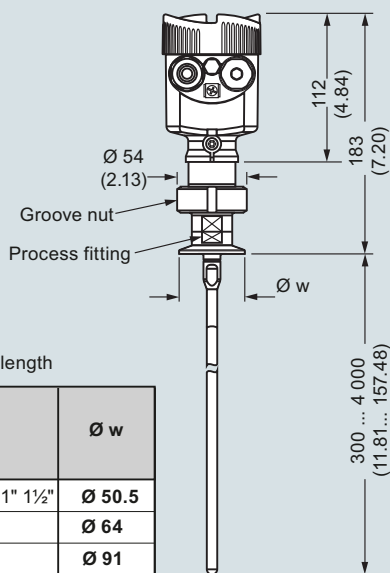

Rod version Ø 8 (0.315), polished

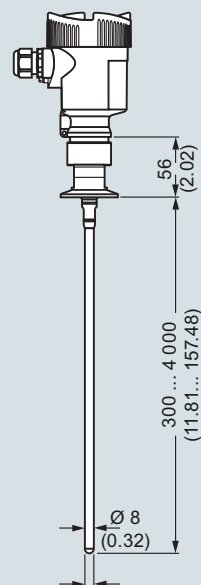

Note: Y01 = total insertion length

| | Ø w |
|-------------------------------|--------|
| DIN DN 25 DN 32 DN 40/ 1" 1½" | Ø 50.5 |
| DIN DN 50/ 2" | Ø 64 |
| DIN DN 65/ 3" | Ø 91 |

SITRANS LG240, dimensions in mm (inch)

Dimensional drawings (continued)

SITRANS LG250

Cable version with gravity weight

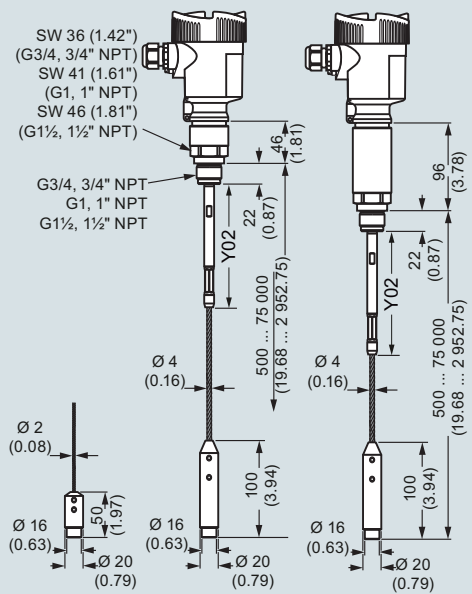

Note: Y01 = total insertion length

Cable version with centering weight

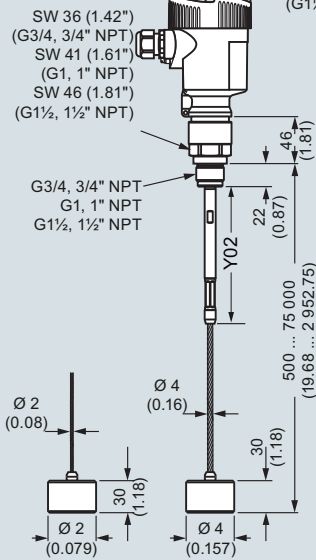

Rod version

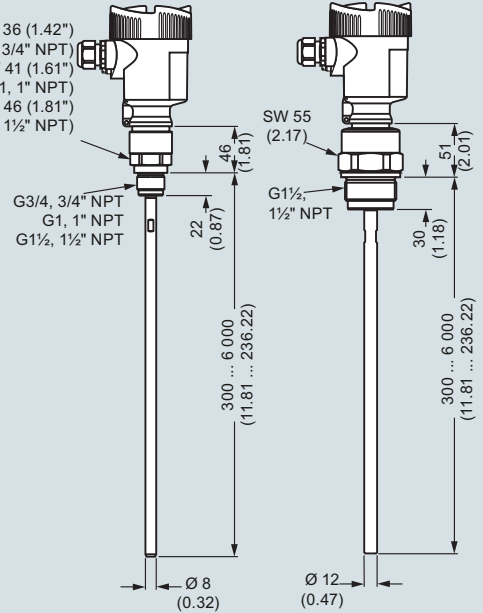

SITRANS LG250, dimensions in mm (inch)

SITRANS LG250, coax version

**Coaxial version
ø 21.3 (0.839)**

**Coaxial version
ø 42.2 (1.661)**

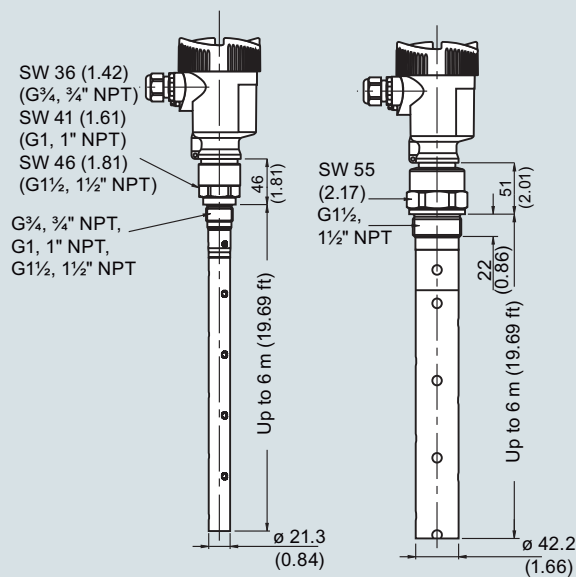

Note: Y01 = total insertion length

SITRANS LG250, dimensions in mm (inch)

Level measurement

Continuous level measurement
Guided wave radar transmitters

SITRANS LG series

Dimensional drawings (continued)

SITRANS LG260

Cable version Ø 4 (0.157)/ Ø 6 (0.236)- PA coated

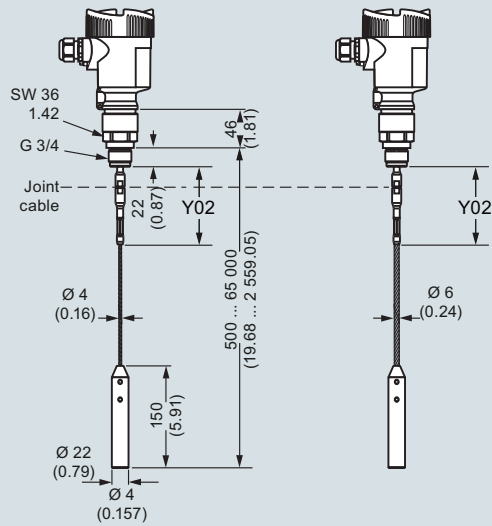

Cable version Ø 6 (0.236)/ Ø 11 (0.433)- PA coated

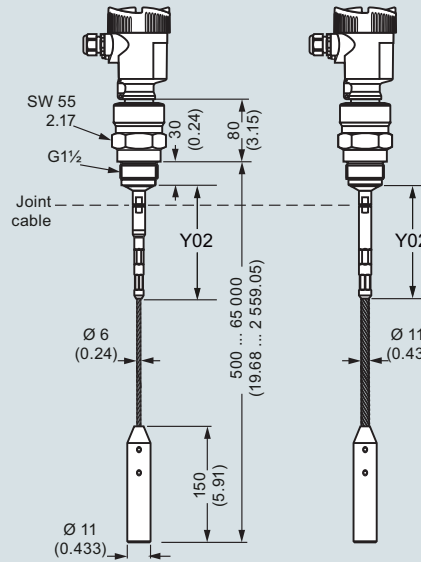

Rod version Ø 16 (0.63)

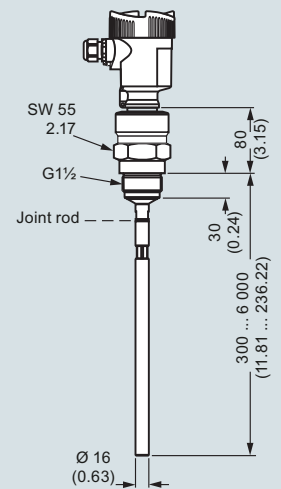

Note: Y01 = total insertion length

SITRANS LG260, dimensions in mm (inch)

Dimensional drawings (continued)

4

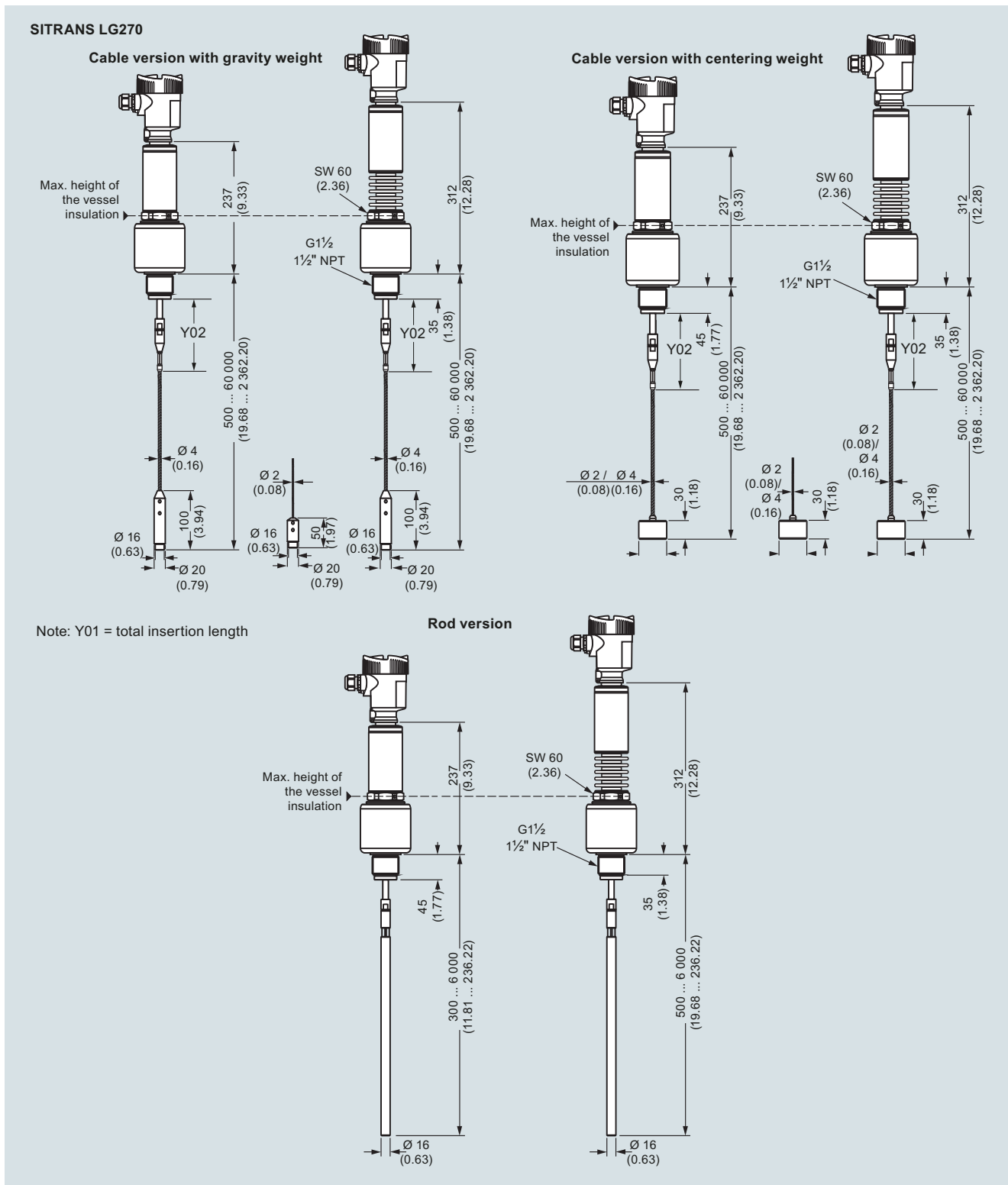

SITRANS LG270, dimensions in mm (inch)

Level measurement

Continuous level measurement
Guided wave radar transmitters

SITRANS LG series

Dimensional drawings (continued)

SITRANS LG270, coax version

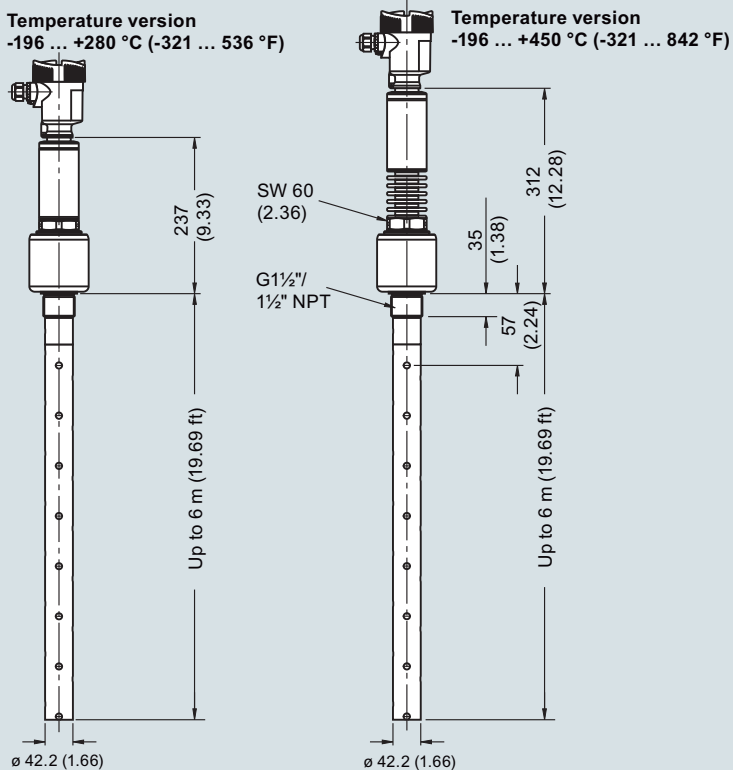

Note: Y01 = total insertion length

SITRANS LG270, dimensions in mm (inch)

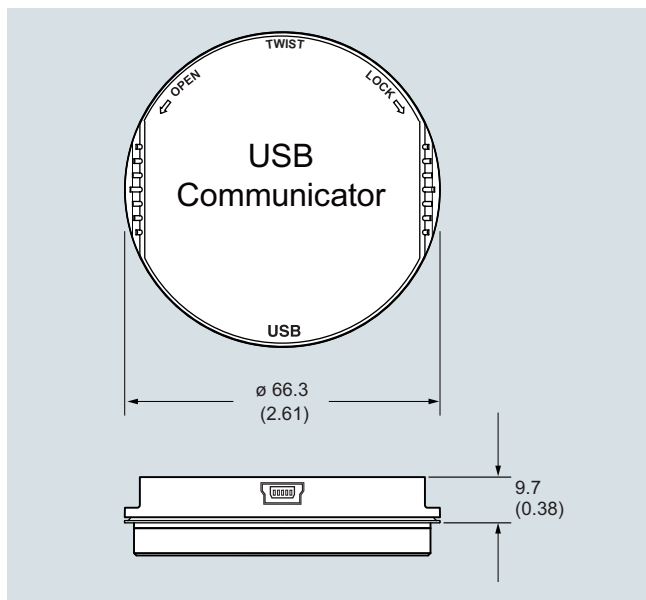

SITRANS LG USB Communicator, dimensions in mm (inch)

Dimensional drawings (continued)

SITRANS LG remote interface, aluminum housing

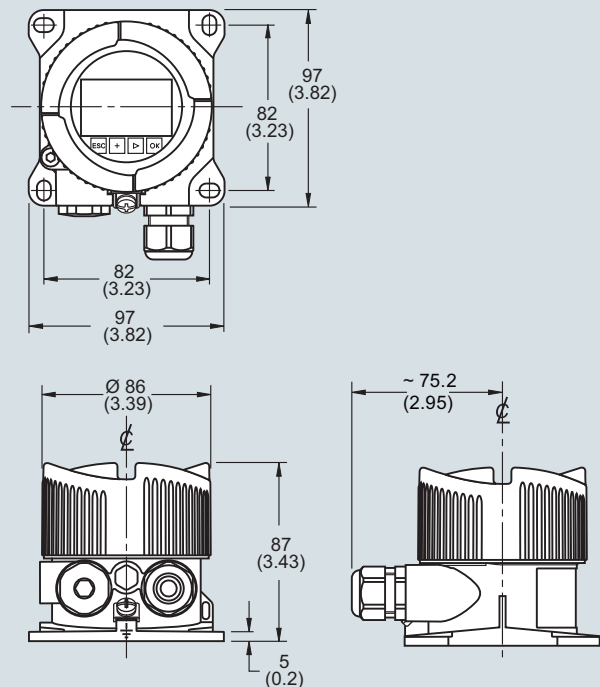

SITRANS LG remote interface, plastic housing

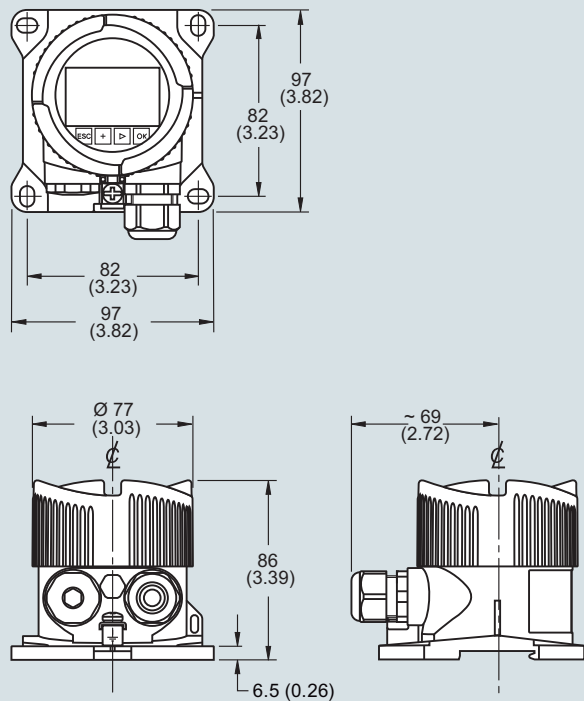

SITRANS LG remote interface, dimensions in mm (inch)

Level measurement

Continuous level measurement
Guided wave radar transmitters

SITRANS LG series

Circuit diagrams

2-wire HART electronic option, electronics and connection compartment, single chamber housing

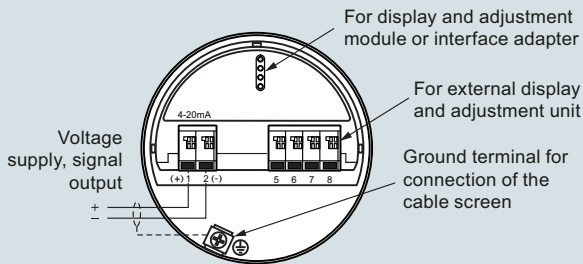

2-wire HART electronic option, electronics compartment, double chamber housing

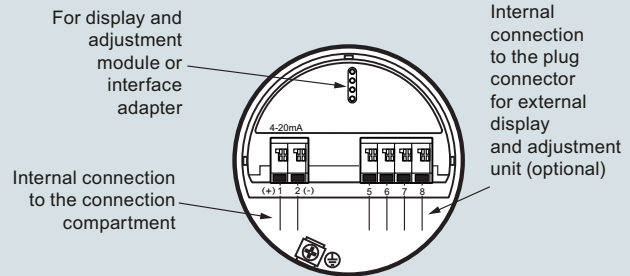

2-wire HART electronic option, connection compartment, Ex-d-ia double chamber housing

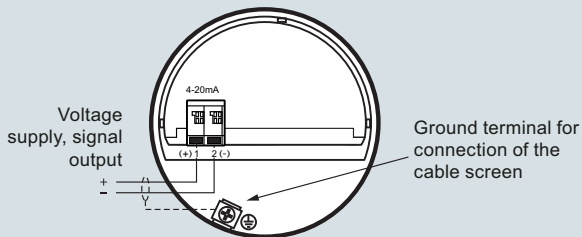

Note: All 2-wire HART connections and electronics are also available with SIL qualification.

SITRANS LG series connections

4-wire HART electronic option, electronics compartment, double chamber housing

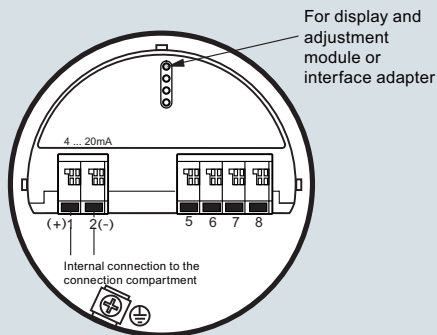

4-wire electronic option, connection compartment, double chamber housing with mains voltage

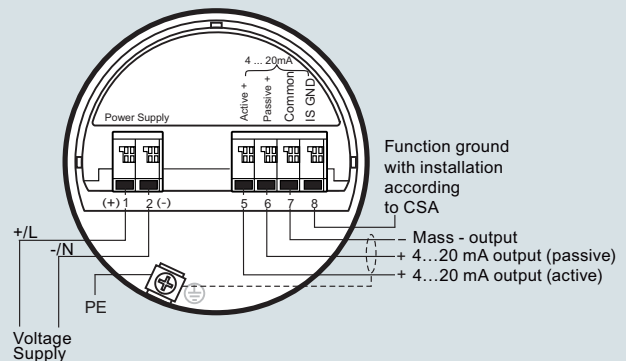

SITRANS LG series connections

Circuit diagrams (continued)

Supplementary electronics

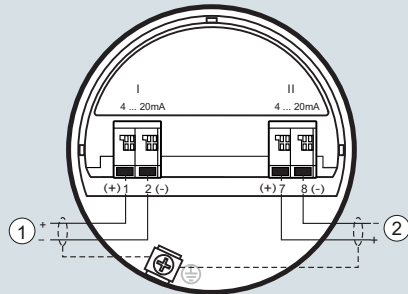

- ① First current output (I) - Voltage supply and signal output (HART)
- ② Second current output (II) - Voltage supply and signal output (without HART)

Connection compartment with low voltage

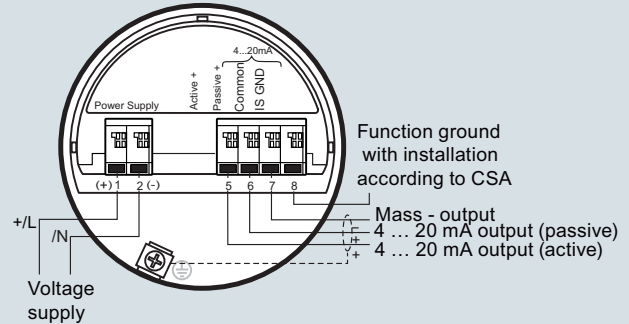

Function ground with installation according to CSA

Mass - output
 4 ... 20 mA output (passive)
 4 ... 20 mA output (active)

SITRANS LG series connections

Modbus electronic option, connection compartment

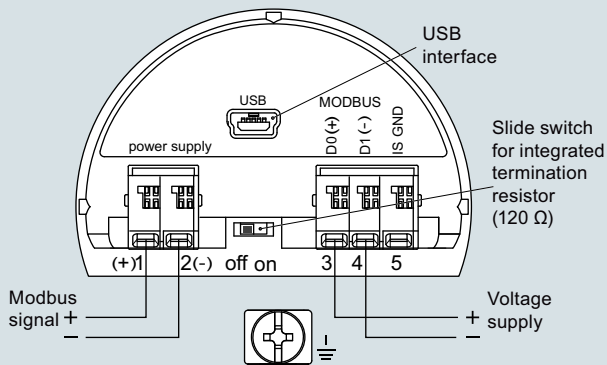

Modbus electronic option, electronics compartment, double chamber housing

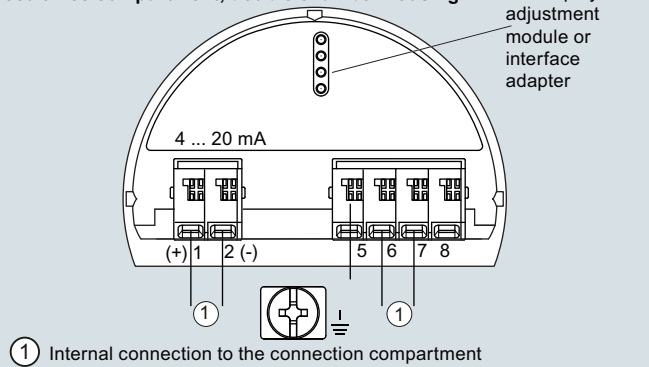

For display and adjustment module or interface adapter

- ① Internal connection to the connection compartment

SITRANS LG series connections

PROFIBUS electronic option, connection compartment, double chamber housing

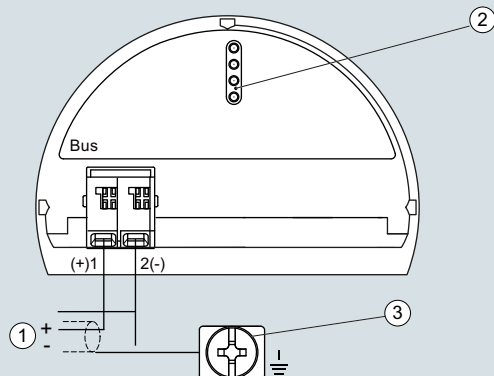

- ① Voltage supply, signal output
- ② For display and adjustment module or interface adapter
- ③ Ground terminal for connection of the cable screen

PROFIBUS electronic option, electronics compartment, double chamber housing

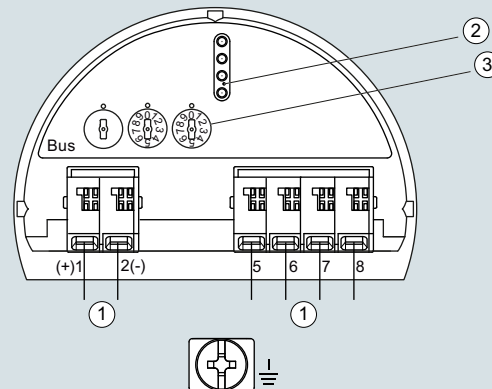

- ① Internal connection to the connection compartment
- ② Contact pins for the display and adjustment module or interface adapter
- ③ Selection switch for bus address

LG series connections

Level measurement

Continuous level measurement
Guided wave radar transmitters

SITRANS LG series

Circuit diagrams (continued)

PROFIBUS electronic option, electronics and connection compartment, single chamber housing

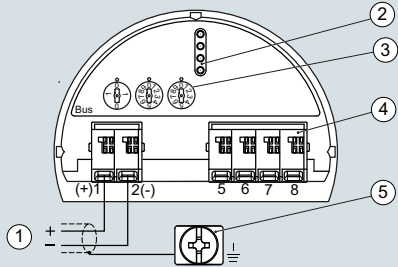

- ① Voltage supply, signal output
- ② For display and adjustment module or interface adapter
- ③ Selection switch for bus address
- ④ For external display and adjustment unit
- ⑤ Ground terminal for connection of the cable screen

LG series connections

LG series, FOUNDATION Fieldbus electronic option, electronic and terminal compartment, single chamber housing

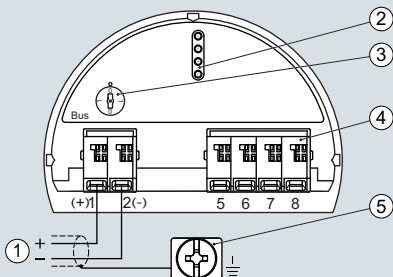

- ① Voltage supply, signal output
- ② Contact pins for the display and adjustment module or interface adapter
- ③ Simulation switch ("1" = mode for simulation release)
- ④ For external display and adjustment unit
- ⑤ Ground terminal for connection of the cable screen

LG series connections

LG series, FOUNDATION Fieldbus electronic option, electronic compartment, double chamber housing

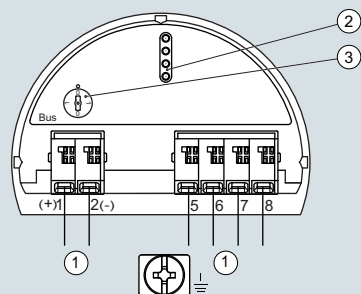

- ① Internal connection to the connection compartment
- ② Contact pins for the display and adjustment module or interface adapter
- ③ Simulation switch ("on" = simulation mode)

LG series, FOUNDATION Fieldbus electronic option, terminal compartment, double chamber housing

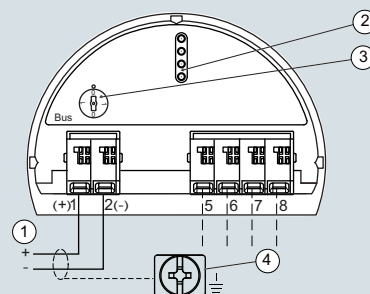

- ① Voltage supply, signal output
- ② For display and adjustment module or interface adapter
- ③ For external display and adjustment unit
- ④ Ground terminal for connection of the cable screen

LG series connections