

Overview



SITRANS LR250 is a 2-wire, 25 GHz pulse radar level transmitter for continuous monitoring of liquids and slurries in storage and process vessels including high temperature and pressure, to a range of 20 m (66 ft).

Benefits

- Graphical local user interface (LUI) makes operation simple with plug-and-play setup using the intuitive Quick Start Wizard
- LUI displays echo profiles for diagnostic support
- 25 GHz high frequency allows for small antennas for easy mounting in nozzles
- Insensitive to mounting location and obstructions, and less sensitive to nozzle interference
- Short blanking distance for improved minimum measuring range to 50 mm (2 inch) from the end of the antenna
- Communication using HART or PROFIBUS PA
- Process Intelligence signal processing for improved measurement reliability and Auto False-Echo Suppression of fixed obstructions
- Programming using infrared Intrinsically Safe handheld programmer or over a network using SIMATIC PDM, Emerson AMS, or Field Device Tools such as PACTware or Fieldcare via SITRANS DTM
- Functional Safety (SIL 2). Device suitable for use in accordance with IEC 61508 and IEC 61511
- 3 mm (0.118 inch) accuracy in accordance with IEC 60770-1
- Suitable for API 2350

Application

SITRANS LR250 includes a graphical local user interface (LUI) that improves setup and operation by including an intuitive Quick Start Wizard, and echo profile displays for diagnostic support. Startup is easy using the Quick Start wizard with a few parameters required for basic operation.

The 25 GHz frequency creates a narrow, focused beam allowing for smaller horn antenna options and decreasing sensitivity to obstructions.

SITRANS LR250's unique design allows safe and simple programming using the Intrinsically Safe handheld programmer without saving to open the instrument's lid.

SITRANS LR250 measures superbly on low dielectric media, and in small vessels, as well as tall and narrow vessels.

- Key Applications: liquid bulk storage tanks, process vessels, vaporous liquids, high temperatures, low dielectric media and applications with functional safety requirements

Configuration

Installation

Note:

- Beam angle is the width of the cone where the energy density is half of the peak energy density.
- The peak energy density is directly in front of and in line with the horn antenna.
- There is a signal transmitted outside of the beam angle; therefore false targets may be detected.
- Use largest possible antenna.

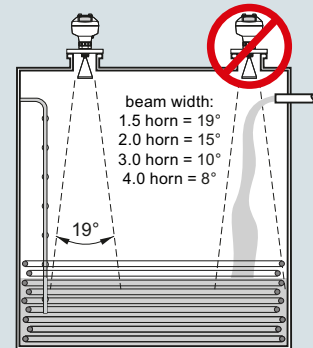

Mounting on bypass

Orient front or back of device toward vent.

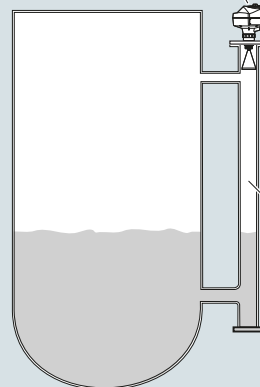

Mounting on stilling well

Orient front or back of device toward stillpipe slots.

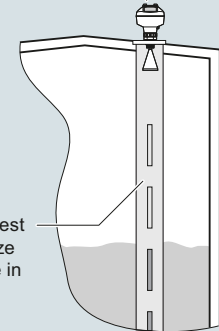

Mounting on vessel

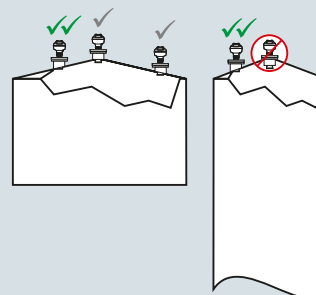

Mounting on a nozzle

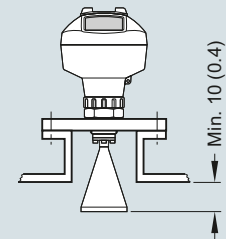

SITRANS LR250 installation, dimensions in mm (inch)

Level measurement

Continuous level measurement
Radar level transmitters

SITRANS LR250 Horn Antenna

Technical specifications

Mode of operation

Measuring principle	Radar level measurement
Frequency	K-band (25.0 GHz)
Minimum measuring range	50 mm (2 inch) from end of antenna
Maximum measuring range	20 m (65 ft), antenna dependent

Output

HART	Version 5.1
• Analog output	4 ... 20 mA
• Accuracy	± 0.02 mA
• Fail-safe	<ul style="list-style-type: none"> Programmable as high low or hold (loss of echo) NE 43 programmable
PROFIBUS PA	Profile 3.01
• Function blocks	2 Analog Input (AI)

Performance (according to reference conditions IEC60770-1)

Maximum measured error	3 mm (0.118 inch)
Influence of ambient temperature	< 0.003 %/K

Rated operating conditions

Installation conditions	
• Location	Indoor/outdoor
Ambient conditions (enclosure)	
• Ambient temperature	-40 ... +80 °C (-40 ... +176 °F)
• Storage temperature	-40 ... +80 °C (-40 ... +176 °F)
• Installation category	I
• Pollution degree	4

Medium conditions

Dielectric constant ϵ_r	> 1.6, antenna and application dependent
Process temperature	-40 ... +200 °C (-40 ... +392 °F) (at process connection with FKM O-ring) -20 ... +200 °C (-4 ... +392 °F) (at process connection with FFKM O-ring)
Process pressure	Up to 40 bar g (580 psi g), process connection and temperature dependent. See Pressure/Temperature curves for more information

Design

Enclosure	
• Material	Aluminum, polyester powder-coated
• Cable inlet	2 x M20 x 1.5 or 2 x 1/2" NPT
Degree of protection	Type 4X/NEMA 4X, Type 6/NEMA 6, IP67, IP68
Weight	< 3 kg (6.6 lb) 3.75 mm (1/2 inch) threaded connection with 1/2" horn antenna
Display (local)	Graphic local user interface including quick start wizard and echo profile display
Antenna	
• Material	316L stainless steel
• Dimensions (nominal horn sizes)	Standard 1.5 inch (40 mm), 2 inch (48 mm), 3 inch (75 mm), 4 inch (95 mm) horn, and optional 100 mm (4 inch) horn extension
Process connections	
• Process connection	1/2", 2" or 3" NPT [(Taper), ASME B1.20.1] R 1/2", 2" or 3" [(BSPT), EN 10226] G 1/2", 2" or 3" [(BSPP), EN ISO 228-1] 2", 3", 4" (ASME 150, 300 lb), 50, 80, 100 mm (PN 16, 40, JIS 10K)
• Flange connection	

Power supply

4 ... 20 mA/HART	Nominal 24 V DC (max. 30 V DC) with max. 550 Ω
PROFIBUS PA	<ul style="list-style-type: none"> 15 mA Per IEC 61158-2

Certificates and approvals

General	cCSA _{US} , CE, UKCA, FM, RCM
Radio	FCC, Industry Canada, RED, RCM
Hazardous	
• Explosion Proof (Brazil)	INMETRO Ex d ia mb IIC T4 Ga/Gb, Ex ia ta IIIC T100 °C Da
• Increased Safety (Brazil)	INMETRO Ex e ia mb IIC T4 Ga/Gb, Ex ia ta IIIC T100 °C Da
• Intrinsically Safe (Brazil)	INMETRO Ex ia IIC T4 Ga, Ex ia ta IIIC T100 °C Da
• Explosion Proof (Canada/USA)	CSA/FM Class I, Div. 1, Groups A, B, C, D; Class II, Div. 1, Groups E, F, G; Class III T4
• Intrinsically Safe (Canada/USA)	CSA/FM Class I, Div. 1, Groups A, B, C, D; Class II, Div. 1, Groups E, F, G; Class III T4
• Non-incendive (Canada/USA)	CSA/FM Class I, Div. 2, Groups A, B, C, D T5
• Flame Proof/Increased Safety (China)	NEPSI Ex d ia mb IIC T4 Ga/Gb, Ex e ia mb IIC T4 Ga/Gb, Ex iaD tD A20 IP67 T100 °C;
• Intrinsically Safe (China)	NEPSI Ex ia IIC T4 Ga, Ex iaD tD A20 IP67 T100 °C;
• Non-sparking (China)	NEPSI Ex nA IIC T4 Gc;
• Intrinsically Safe (EU)	ATEX II 1G Ex ia IIC T4 Ga, ATEX II 1D Ex ia ta IIIC T100°C Da; UKEX II 1G Ex ia IIC T4 Ga, UKEX II 1D Ex ia ta IIIC T100°C Da; IECEX Ex ia IIC T4 Ga, IECEX Ex ia ta IIIC T100°C Da;
• Intrinsically Safe (UK)	ATEX II 3G Ex ec IIC T4 Gc UKEX II 3G Ex ec IIC T4 Gc; EAC Ex 2Ex nA IIC T4 Gc; ATEX II 1/2 GD, 1D, 2D, Ex db mb ia IIC Ga/Gb, Ex ia ta IIIC T100°C Da; UKEX II 1/2 GD, 1D, 2D, Ex db mb ia IIC Ga/Gb, Ex ia ta IIIC T100°C Da; IECEX Ex db mb ia IIC T4 Ga/Gb, Ex ia ta IIIC T100°C Da;
• Increased Safety - Zone 2 (EU)	ATEX II 1/2 GD, 1D, 2D, Ex eb mb ia IIC T4 Ga/Gb, Ex ia ta IIIC T100°C Da;
• Increased Safety - Zone 2 (UK)	UKEX II 1/2 GD, 1D, 2D, Ex eb mb ia IIC T4 Ga/Gb, Ex ia ta IIIC T100°C Da;
• Non-sparking (EAC)	IECEX Ex db mb ia IIC T4 Ga/Gb, Ex ia ta IIIC T100°C Da; EAC Ex d
• Flameproof (EU)	EAC Ex e
• Flameproof (UK)	EAC Ex ia
• Flameproof (International)	
• Increased Safety - Zone 1 (EU)	ATEX II 1/2 GD, 1D, 2D, Ex eb mb ia IIC T4 Ga/Gb, Ex ia ta IIIC T100°C Da;
• Increased Safety - Zone 1 (UK)	UKEX II 1/2 GD, 1D, 2D, Ex eb mb ia IIC T4 Ga/Gb, Ex ia ta IIIC T100°C Da;
• Increased Safety - Zone 1 (International)	IECEX Ex eb mb ia IIC T4 Ga/Gb, Ex ia ta IIIC T100°C Da
• Explosion Proof (Russia/Kazakhstan)	EAC Ex d
• Increased Safety (Russia/Kazakhstan)	EAC Ex e
• Intrinsically Safe (Russia/Kazakhstan)	EAC Ex ia
• Marine	
• Functional Safety	<ul style="list-style-type: none"> Lloyd's Register of Shipping ABS Type Approval Bureau Veritas SIL-2 suitable in accordance with IEC 61508/61511

Programming

Intrinsically Safe Siemens handheld programmer	Infrared receiver IS model: ATEX II 1 GD Ex ia op is IIC T4 Ga ATEX II 1 GD Ex ia op is IIIC T135°C Da UKEX II 1 GD Ex ia op is IIC T4 Ga UKEX II 1 GD Ex ia op is IIIC T135°C Da Ta = -20 ... +50°C CSA/FM Class I, II, III, Div. 1, Groups A, B, C, D, E, G, T6 Ta = 50°C IECEx SIR 09.0073
Handheld communicator	HART communicator 375/475
PC	<ul style="list-style-type: none"> • SIMATIC PDM • Emerson AMS • SITRANS DTM (for connection into FDT such as PACTware or Fieldcare)
Display (local)	Graphic local user interface including quick start wizard and echo profile displays

Level measurement

Continuous level measurement Radar level transmitters

SITRANS LR250 Horn Antenna

Selection and ordering data

Article No.

SITRANS LR250 Radar level transmitter

Continuous, non-contact, 20 m (66 ft) range, for liquids and slurries.

➤ Click on the Article No. for the online configuration in the PIA Life Cycle Portal.

Process Connection and Antenna Material

316L (1.4435 or 1.4404) stainless steel, PTFE emitter, FKM seal¹⁾

316L (1.4435 or 1.4404) stainless steel, PTFE emitter, FFKM seal¹⁾

Process Connection Type

Threaded connection 316L

1½" NPT (ASME B1.20.1) (tapered thread)³⁾

R 1½" [(BSPT), EN 10226-1] (tapered thread)³⁾

G 1½" [(BSPP), EN ISO 228-1] (parallel thread)³⁾

2" NPT (ASME B1.20.1) (tapered thread)⁴⁾

R 2" [(BSPT), EN 10226-1] (tapered thread)⁴⁾

G 2" [(BSPP), EN ISO 228-1] (parallel thread)⁴⁾

3" NPT (ASME B1.20.1) (tapered thread)⁴⁾

R 3" [(BSPT), EN 10226-1] (tapered thread)⁴⁾

G 3" [(BSPP), EN ISO 228-1] (parallel thread)⁴⁾

Flanged connection 316L

2" Class 150 ASME B16.5, raised face⁴⁾

3" Class 150 ASME B16.5, raised face⁴⁾

4" Class 150 ASME B16.5, raised face⁴⁾

2" Class 300 ASME B16.5, raised face⁴⁾

3" Class 300 ASME B16.5, raised face⁴⁾

4" Class 300 ASME B16.5, raised face⁴⁾

50A 10K JIS B 2220 flat face⁴⁾

80A 10K JIS B 2220 flat face⁴⁾

100A 10K JIS B 2220 flat face⁴⁾

DN 50 PN 16 EN 1092-1 Type B1 raised face⁴⁾

DN 80 PN 16 EN 1092-1 Type B1 raised face⁴⁾

DN 100 PN 16 EN 1092-1 Type B1 raised face⁴⁾

DN 150 PN 16 EN 1092-1 Type B1 raised face⁴⁾

DN 50 PN 40 EN 1092-1 Type B1 raised face⁴⁾

DN 80 PN 40 EN 1092-1 Type B1 raised face⁴⁾

DN 100 PN 40 EN 1092-1 Type B1 raised face⁴⁾

DN 150 PN 40 EN 1092-1 Type B1 raised face⁴⁾

Communication/Output

PROFIBUS PA⁵⁾

4 ... 20 mA, HART, start-up at < 3.6 mA

Enclosure/Cable inlet

Aluminum, Epoxy painted

2 x ½" NPT

2 x M20 x 1.5

Antenna

1½" horn

2" horn (fits 2" ASME or DN 50 nozzles)

3" horn (fits 3" ASME or DN 80 nozzles)

4" horn (fits 4" ASME or DN 100 nozzles)

1½" horn with 100 mm extension

2" horn with 100 mm extension

3" horn with 100 mm extension

4" horn with 100 mm extension

7ML5431-

0 -

0 -

0 -

0 -

0 -

0 -

0 -

0 -

0 -

0 -

0 -

0 -

0 -

0 -

0 -

0 -

0 -

0 -

0 -

0 -

0 -

0 -

0 -

0 -

0 -

0 -

0 -

0 -

0 -

0 -

0 -

0 -

0 -

0 -

0 -

0 -

0 -

0 -

0 -

0 -

0 -

0 -

0 -

0 -

0 -

0 -

0 -

0 -

0 -

0 -

0 -

0 -

0 -

0 -

0 -

0 -

0 -

0 -

0 -

0 -

0 -

0 -

0 -

0 -

0 -

0 -

0 -

0 -

0 -

0 -

0 -

Article No.

SITRANS LR250 Radar level transmitter

Continuous, non-contact, 20 m (66 ft) range, for liquids and slurries.

Approvals

Ordinary Locations/General Purpose (Non-Ex), CE, UKCA, CSA, FM, FCC, RED, RCM

Intrinsically Safe: CSA/FM Class I, Div. 1, Groups A, B, C, D, Class II, Div. 1, Groups E, F, G, Class III T4 FCC, Industry Canada

Intrinsically Safe:

ATEX II 1G Ex ia IIC T4 Ga,

ATEX II 1D Ex ia ta IIIC T100°C Da;

UKEX II 1G Ex ia IIC T4 Ga,

UKEX II 1D Ex ia ta IIIC T100°C Da;

IECEx Ex ia IIC T4 Ga,

IECEx 1D Ex ia ta IIIC T100°C Da;

INMETRO Ex ia IIC T4 Ga,

INMETRO Ex ia ta IIIC T100°C Da,

IP67/IP68;

EAC Ex 0Ex ia IIC T4 Ga X,

EAC Ex 0Ex ia ta IIIC T100°C Da X;

CE, UKCA, RED, RCM

Non-incendive: CSA/FM Class I, Div. 2,

Groups A, B, C, D T5, FCC, Industry Canada

Increased Safety / Non Sparking:

ATEX II 3G Ex ec IIC T4 Gc;

UKEX II 3G Ex ec IIC T4 Gc;

EAC Ex 2Ex nA IIC T4 Gc X;

CE, UKCA, RED, RCM

Increased Safety:

ATEX II 1/2 GD, 1D, 2D, Ex eb mb ia IIC T4 Ga/Gb;

UKEX II 1/2 GD, 1D, 2D, Ex eb mb ia IIC T4 Ga/Gb;

IECEx Ex eb ia mb IIC T4 Ga/Gb;

INMETRO Ex e ia mb IIC T4 Ga/Gb,

INMETRO Ex ia ta IIIC T100°C Da,

IP67/IP68;

EAC Ex Ga/Gb Ex ia/e+mb IIC T4 X;

CE, UKCA, RED, RCM⁶⁾

Flameproof:

ATEX II 1/2 GD, 1D, 2D, Ex db mb ia IIC T4 Ga/Gb;

ATEX II 1/2 GD, 1D, 2D, Ex ia ta IIIC T100°C Da;

UKEX II 1/2 GD, 1D, 2D, Ex db mb ia IIC T4 Ga/Gb;

UKEX II 1/2 GD, 1D, 2D, Ex ia ta IIIC T100°C Da;

IECEx Ex db mb ia IIC T4 Ga/Gb,

IECEx Ex ia ta IIIC T100°C Da;

INMETRO Ex d ia mb IIC T4 Ga/Gb,

INMETRO Ex ia ta IIIC T100°C Da,

IP67/IP68;

EAC Ex Ga/Gb Ex ia/db+mb IIC T4 X,

EAC Ex Ex ia ta IIIC T100°C Da;

CE, UKCA, RED, RCM⁶⁾

Explosion proof: CSA/FM Class I, II, and III, Div. 1,

Groups A, B, C, D, E, F, G, FCC, Industry Canada⁶⁾

Non Sparking: NEPSI Ex nA IIC T4 Gc

Intrinsically Safe: NEPSI Ex ia IIC T4 Ga,

Ex iaD tD A20 IP67 T100 °C

Flameproof: NEPSI Ex d ia mb IIC T4 Ga/Gb,

Ex iaD tD A20 IP67 T100 °C⁶⁾

Increased Safety: NEPSI Ex e ia mb IIC T4 Ga/Gb,

Ex iaD tD A20 IP67 T100 °C⁶⁾

Pressure rating

Rating per Pressure/Temperature curves in manual

0.5 bar g (7.25 psi g) maximum⁷⁾

1) Available with process connection options AA ... HD and Antenna Versions A ... H only.

2) Available with process connection options JA ... MH and Antenna Versions J ... P only.

3) Not available with Antenna options B, C, D, F, G, H.

4) Not available with Antenna options A and E.

5) Available with Approval options A, B, C, D, K, and L.

6) Available only with Communications option 2.

7) Available with Process Connection and Antenna Material 0, 1, 2, and 3 only.

Selection and ordering data	Article No.	Accessories	Article No.
Further designs			
Please add "-Z" to Article No. and specify Order code(s).		Handheld programmer, Intrinsically safe, EEx ia	7ML1930-1BK
Plug M12 with mating Connector ¹⁾²⁾³⁾	A50	HART modem/USB (for use with a PC and SIMATIC PDM)	7MF4997-1DB
Plug 7/8" with mating Connector ²⁾³⁾⁴⁾	A55	One metallic cable gland M20 x 1.5, rated -40 ... +80 °C (-40 ... +176 °F), HART (two are required)	7ML1930-1AP
Stainless steel tag [69 x 50 mm (2.71 x 1.97 inch)]: Measuring-point number/identification (max. 27 characters); specify in plain text	Y15	One metallic cable gland M20 x 1.5, rated -40 ... +80 °C (-40 ... +176 °F), PROFIBUS PA (two are required) ⁶⁾	7ML1930-1AQ
Manufacturer's Test Certificate: M to DIN 55350, Part 18 and to ISO 9000	C11	FDA approved FKM O-ring for 2" G (BSPP) process connections -28 ... +80 °C (-28 ... +176 °F)	7ML1830-3AN
Material inspection certificate 3.1 of EN 10204	C12	SITRANS RD100, loop powered display - see Chapter 7	7ML5741-.....-
Functional Safety (SIL 2). Device suitable for use in accordance with IEC 61508 and IEC 61511 ³⁾⁵⁾	C20	SITRANS RD150, remote digital display for 4 ... 20 mA and HART devices - see Chapter 7	7ML5742-.....-
Namur NE43 compliant, device preset to failsafe < 3.6 mA ⁵⁾	N07	SITRANS RD200, universal input display with Modbus conversion - see Chapter 7	7ML5740-.....-
Operating Instructions		SITRANS RD300, dual line display with totalizer and linearization curve and Modbus conversion - see Chapter 7	7ML5744-.....-
All literature is available to download for free, in a range of languages, at http://www.siemens.com/processinstrumentation/documentation		For applicable back up point level switch - see point level measurement section	
		<ol style="list-style-type: none"> 1) Available with enclosure option 1 only. 2) To be used with communication options 1 and 3 only. Connector has IP67 rating. 3) Available with approval options A and B. Available with approval option C for use on intrinsically safe applications only. Not rated for dust Ex. 4) Available with enclosure option 0 only. 5) Applicable to communication option 2 only. 6) For use with communication options 1 and 3 only. 	

Level measurement

Continuous level measurement
Radar level transmitters

SITRANS LR250 Horn Antenna

SITRANS LR250 Spare parts

SITRANS LR250 horn version enclosures (PROFIBUS PA models)



SITRANS LR250 horn version enclosure with board stack, NPT cable inlet, approval option A, with PROFIBUS PA communication, no process connection

A5E01156836

SITRANS LR250 horn version enclosure with board stack, M20 cable inlet, approval option A, with PROFIBUS PA communication, no process connection

A5E01156838

SITRANS LR250 horn version enclosure with board stack, M20 cable inlet, approval option B, with PROFIBUS PA communication, no process connection

A5E01156841

SITRANS LR250 horn version enclosure with board stack, NPT cable inlet, approval option C, with PROFIBUS PA communication, no process connection

A5E01156843

SITRANS LR250 horn version enclosure with board stack, M20 cable inlet, approval option C, with PROFIBUS PA communication, no process connection

A5E01156844

SITRANS LR250 horn version enclosure with board stack, NPT cable inlet, approval option D, with PROFIBUS communication, no process connection

A5E01156846

SITRANS LR250 horn version enclosure with board stack, M20 cable inlet, approval option D, with PROFIBUS PA communication, no process connection

A5E01156848

SITRANS LR250 horn version enclosures (< 3.6 mA start-up HART)



SITRANS LR250 horn version enclosure with board stack, M20 cable inlet, approval option A, with HART communication start-up at < 3.6 mA, no process connection

A5E02956317

SITRANS LR250 horn version enclosure with board stack, M20 cable inlet, approval option C, with HART communication start-up at < 3.6 mA, no process connection

A5E02956319

SITRANS LR250 horn version enclosure with board stack, M20 cable inlet, approval option E, with HART communication start-up at < 3.6 mA, no process connection

A5E02956320

SITRANS LR250 horn version enclosure with board stack, M20 cable inlet, approval option F, with HART communication start-up at < 3.6 mA, no process connection

A5E02956322

SITRANS LR250 horn version enclosure with board stack, M20 cable inlet, approval option G, with HART communication start-up at < 3.6 mA, no process connection

A5E02956323

LR250 horn version enclosure with board stack, NPT cable inlet, approval option A, with HART communication start-up at < 3.6 mA, no process connection

A5E03441096

LR250 horn version enclosure with board stack, NPT cable inlet, approval option B, with HART communication start-up at < 3.6 mA, no process connection

A5E03441097

LR250 horn version enclosure with board stack, NPT cable inlet, approval option H, with HART communication start-up at < 3.6 mA, no process connection

A5E03441099

Sun shield for SITRANS LR250 enclosure, stainless steel

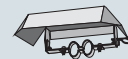

A5E39142556

SITRANS LR250 horn antenna and extension kits



38 mm (1.5 inch) horn antenna kit, 1.5 inch Process Connections only

A5E01151539

100 mm (4 inch) horn antenna extension kit, 1.5 inch process connections only

A5E01151553

50 mm (2 inch) stainless steel 316L horn antenna kit

A5E01151569

75 mm (3 inch) stainless steel 316L horn antenna kit

A5E01151571

100 mm (4 inch) stainless steel 316L horn antenna kit

A5E01151573

100 mm (4 inch) horn antenna extension kit, 50 mm (2 inch), 75 mm (3 inch), and 100 mm (4 inch) process connection

A5E01151577

5 Dupont 1Gr Polyback, PTFE grease kit

A5E01151626

SITRANS LR250 lid with O-ring

A5E02465410

Ex-proof plugs

Ex-proof plugs kit, 1/2" NPT, qty 5

A5E39979991

Ex-proof plugs kit, M20, qty 5

A5E39979992

Emitter kit for SITRANS LR250 horn antenna

Emitter kit for horn antenna

A5E39242718

For special requests please consult a local sales person.
For more information, please visit
http://www.automation.siemens.com/aspa_app.

Characteristic curves

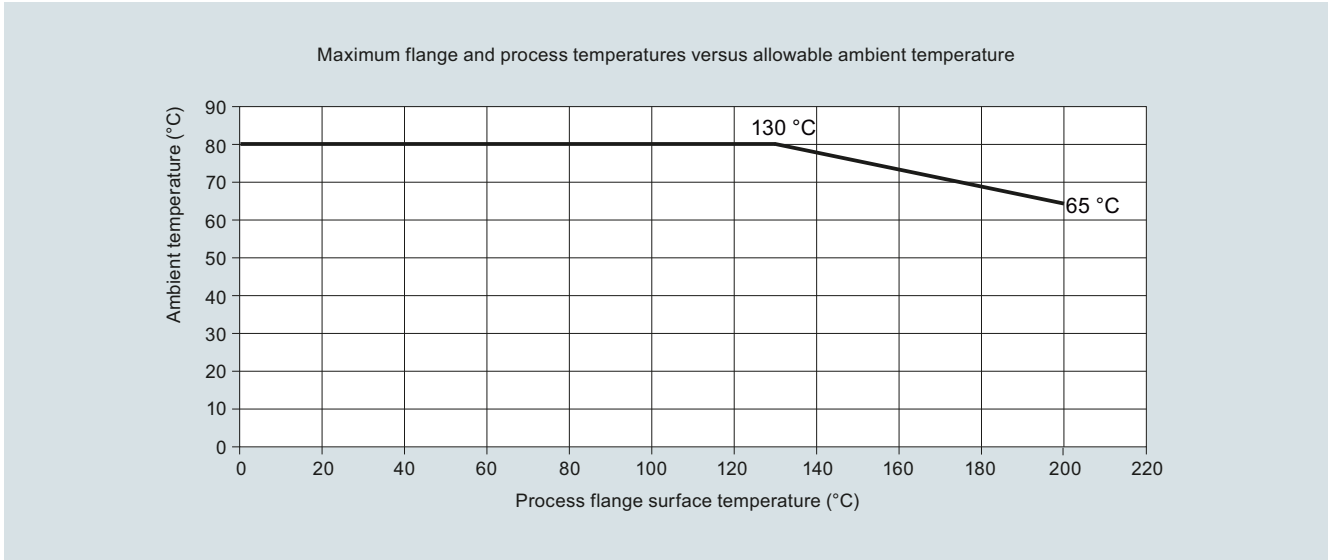

SITRANS LR250 ambient/process flange surface temperature curve

Level measurement

Continuous level measurement
Radar level transmitters

SITRANS LR250 Horn Antenna

Dimensional drawings

Threaded Horn Antenna

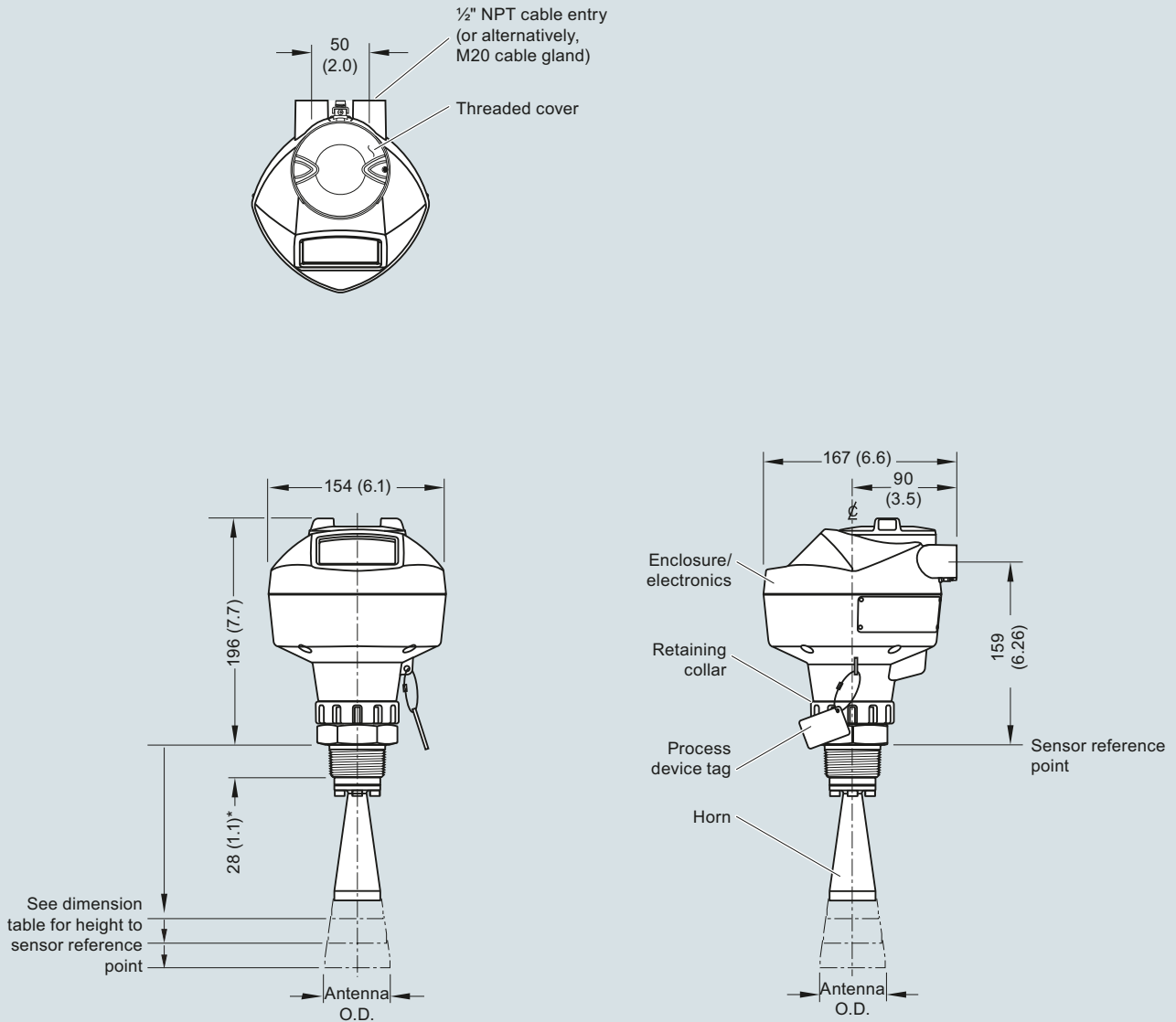

*28 mm (1.1) for 1.5 inch and 2 inch, 42 mm (1.65) for 3 inch

Antenna Type	Antenna O.D.	Height to sensor reference point			Beam angle	Measurement range
		1-1/2" threaded connection	2" threaded connection	3" threaded connection		
1.5" horn	39.8 (1.57)	135 (5.3)	N/A	N/A	19 degrees	10 m (32.8 ft)
2" horn	47.8 (1.88)	N/A	166 (6.55)	180 (7.09)	15 degrees	20 m (65.6 ft)
3" horn	74.8 (2.94)	N/A	199 (7.85)	213 (8.39)	10 degrees	20 m (65.6 ft)
4" horn	94.8 (3.73)	N/A	254 (10)	268 (10.55)	8 degrees	20 m (65.6 ft)

SITRANS LR250 Threaded Horn Antenna, dimensions in mm (inch)

Dimensional drawings (continued)

Threaded Horn Antenna with Extension

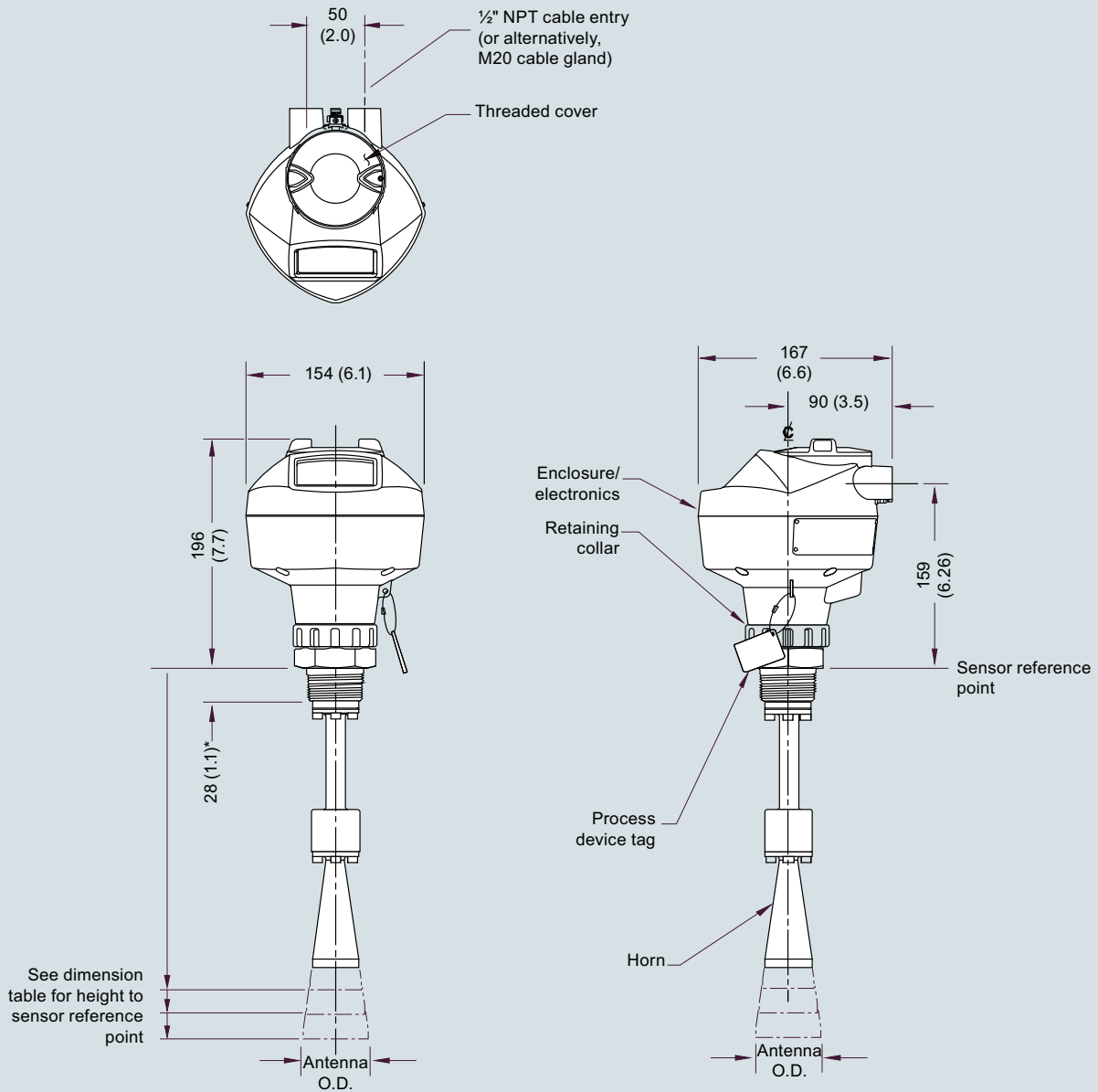

*28 mm (1.1) for 1.5 inch and 2 inch, 42 mm (1.65) for 3 inch

Antenna Type	Antenna O.D.	Height to sensor reference point			Beam angle	Measurement range
		1-1/2" threaded connection	2" threaded connection	3" threaded connection		
1.5" horn	39.8 (1.57)	235 (9.3)	N/A	N/A	19 degrees	10 m (32.8 ft)
2" horn	47.8 (1.88)	N/A	266 (10.47)	280 (11.02)	15 degrees	20 m (65.6 ft)
3" horn	74.8 (2.94)	N/A	299 (11.77)	313 (12.32)	10 degrees	20 m (65.6 ft)
4" horn	94.8 (3.73)	N/A	354 (13.94)	368 (14.49)	8 degrees	20 m (65.6 ft)

SITRANS LR250 Threaded Horn Antenna with extension, dimensions in mm (inch)

Level measurement

Continuous level measurement
Radar level transmitters

SITRANS LR250 Horn Antenna

Dimensional drawings (continued)

Flanged Horn

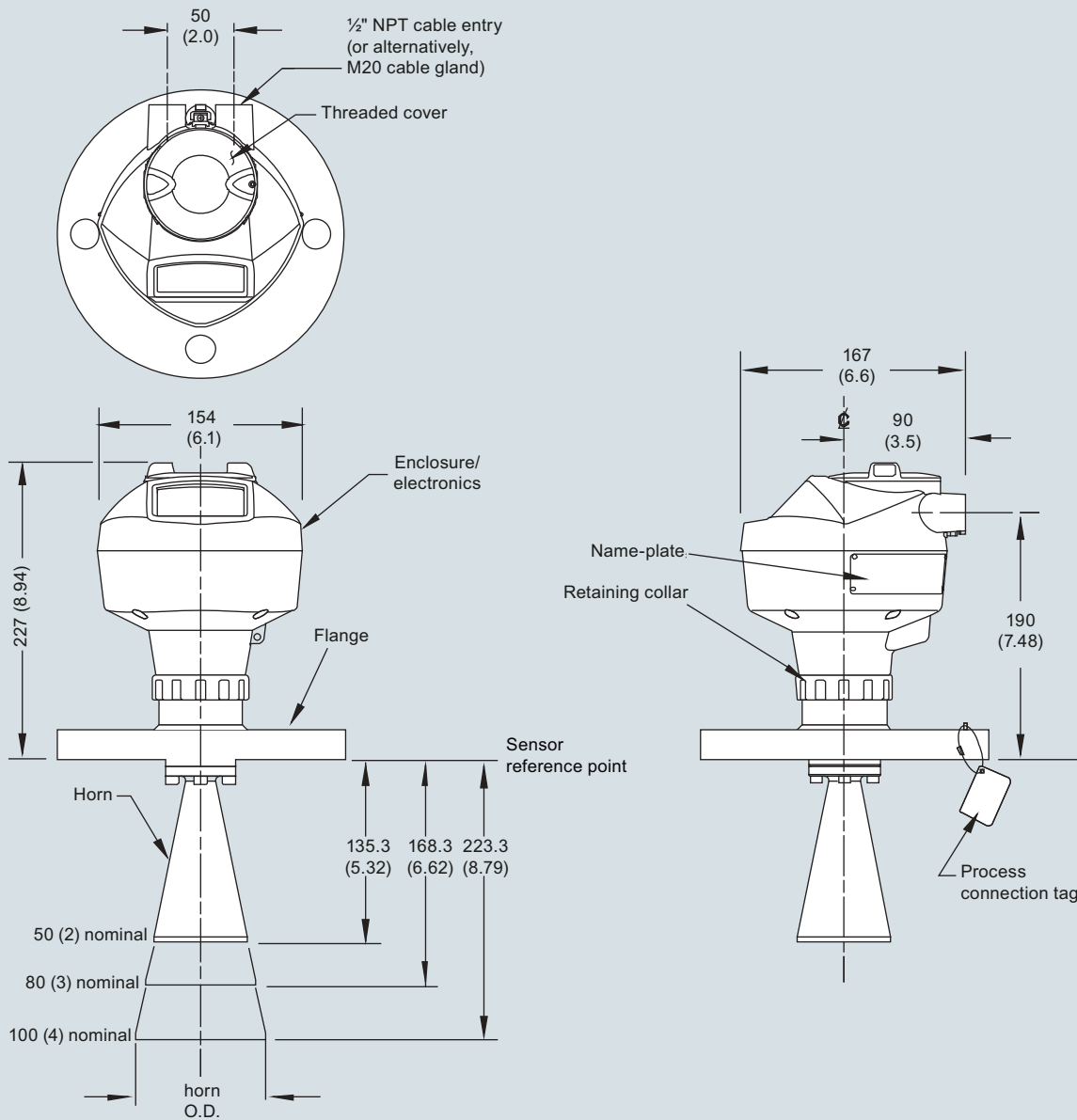

Nominal Horn Size	Horn O.D.	Height to sensor reference point		Beam angle	Measurement range
		Stainless steel flange raised or flat-faced	Optional alloy flange		
50 (2)	47.8 (1.88)	135.3 (5.32)	138.3 (5.44)	15 degrees	20 m (65.6 ft)
80 (3)	74.8 (2.94)	168.3 (6.62)	171.3 (6.74)	10 degrees	20 m (65.6 ft)
100 (4)	94.8 (3.73)	223.3 (8.79)	226.3 (8.90)	8 degrees	20 m (65.6 ft)

SITRANS LR250 Flanged Horn Antenna, dimensions in mm (inch)

Flanged Horn with Extension

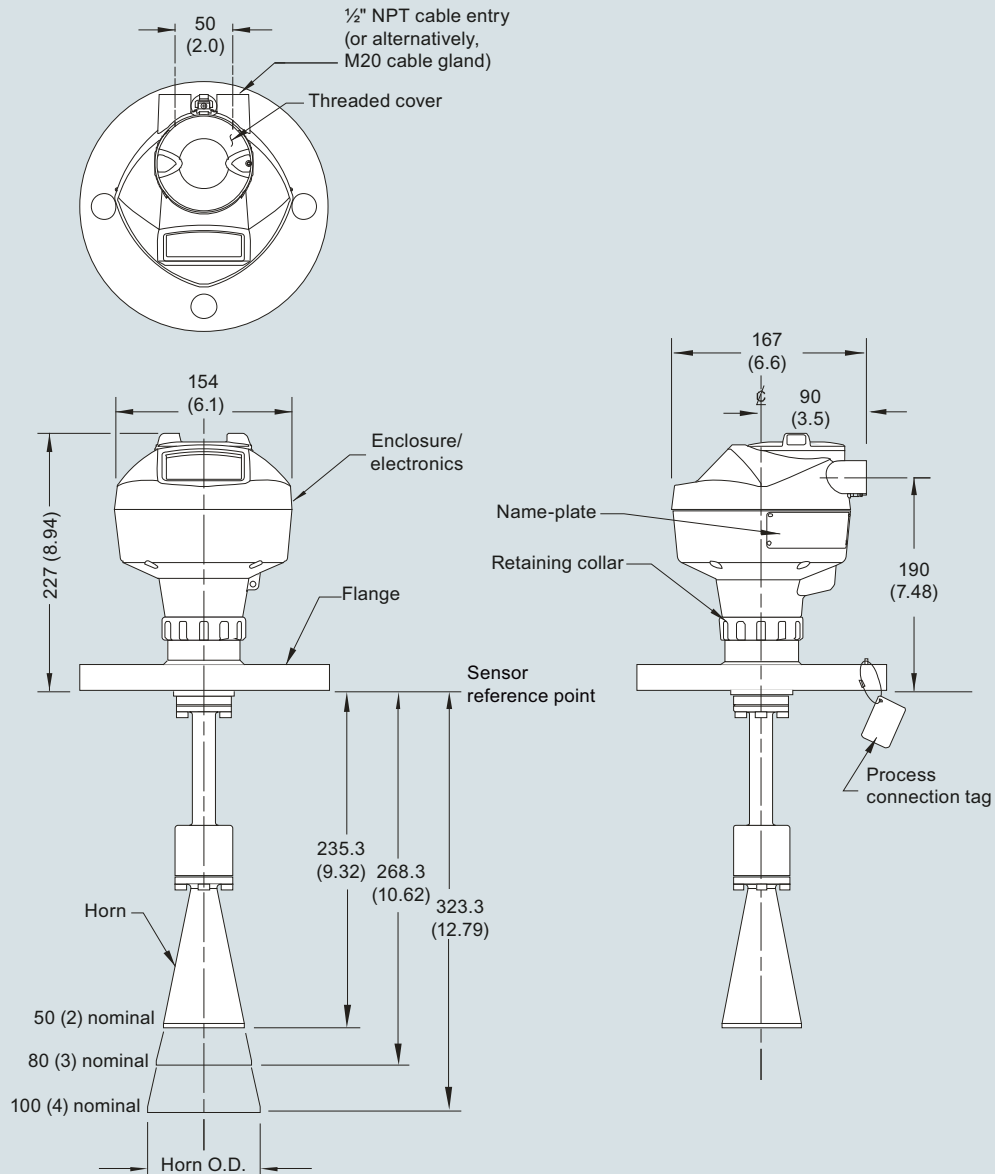

Nominal Horn Size	Horn O.D.	Height to sensor reference point		Beam angle	Measurement range
		Stainless steel flange raised or flat-faced	Optional alloy flange		
50 (2)	47.8 (1.88)	235.3 (9.26)	238.3 (9.38)	15 degrees	20 m (65.6 ft)
80 (3)	74.8 (2.94)	268.3 (10.56)	271.3 (10.68)	10 degrees	20 m (65.6 ft)
100 (4)	94.8 (3.73)	323.3 (12.73)	326.3 (12.85)	8 degrees	20 m (65.6 ft)

SITRANS LR250 Flanged Horn Antenna with extension, dimensions in mm (inch)

Level measurement

Continuous level measurement
Radar level transmitters

SITRANS LR250 Horn Antenna

Circuit diagrams

4

Connect the wires to the terminals as shown: the polarity is identified on the terminal block.

Gland may or may not be provided depending on approval option.

Shield for HART and PROFIBUS PA Intrinsically Safe versions only.

Hand Programmer

SIEMENS			
1	2	3	4
5	6	7	8
9	0	.	+/−
C	⏠	☰	⏴
←	↑	↓	→

Part number:
7ML1930-1BK

Notes:

1. DC terminal shall be supplied from a source providing electrical isolation between the input and output, to meet the applicable safety requirements of IEC 61010-1.
2. All field wiring must have insulation suitable for rated input voltages.
3. Use shielded twisted pair cable (14 ... 22 AWG) for HART version.
4. Separate cables and conduit may be required to conform to standard instrumentation wiring practices or electrical codes.

SITRANS LR250 connections