

Overview



SITRANS LVL200 is a standard vibrating level switch for material detection in liquid and slurry applications such as overflow, high, low, and demand applications, as well as pump protection. For use in SIL-2 applications.

Benefits

- Proven vibrating level switch technology for liquids
- Compact insertion length of 40 mm (1.57 inch) for confined space applications
- Fault monitoring for corrosion, loss of vibration or line break to the piezo drive
- Functional Safety (SIL 2). Device suitable for use in accordance with IEC 61508 and IEC 61511
- Hygienic process connections
- Suitable for API 2350
- Optional remote test signal conditioner

Application

SITRANS LVL200 is a level switch designed for industrial use in all areas of process technology and can be used with liquids and slurries. With a tuning fork insertion length of only 40 mm (1.57 inch), SITRANS LVL200 can be mounted in small pipes and applications with confined space. The LVL200 can be used to measure products with a minimum density of $> 0.5 \text{ g/cm}^3$ (0.018 lb/in^3). The LVL200 can be used in difficult conditions including turbulence, air bubbles, foam generation, buildup, or external vibration.

SITRANS LVL200 continuously monitors faults via frequency evaluation, providing early detection of strong corrosion or damage on the tuning fork, loss of vibration, or a line break to the piezo drive.

The tuning fork is piezoelectrically energized and vibrates at its mechanical resonance frequency of approximately 1 200 Hz. The vibration frequency changes when the tuning fork is covered by the medium. This change is detected by the integrated oscillator and converted into a switching command. The integrated electronics evaluate the level signal and output a switching signal, directly operating connected devices.

The optional signal conditioner provides a remote test feature to ensure continuous product reliability.

- Key Applications: for use in liquids and slurries, for level measurement, overflow, and dry run protection

Configuration

Horizontal mounting

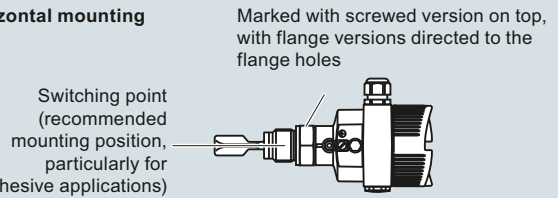

Vertical mounting

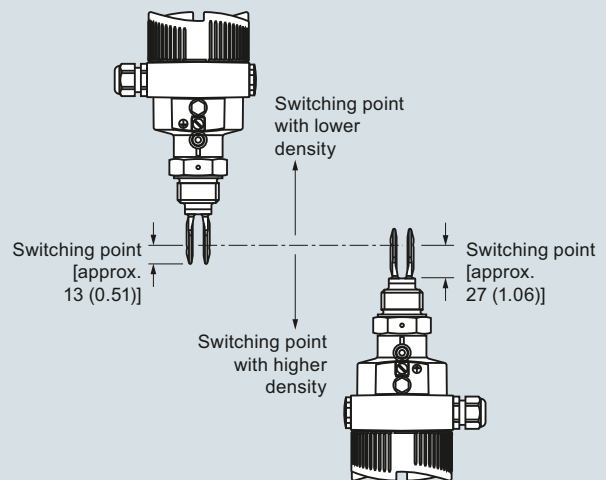

Mount away from filling openings or agitators.

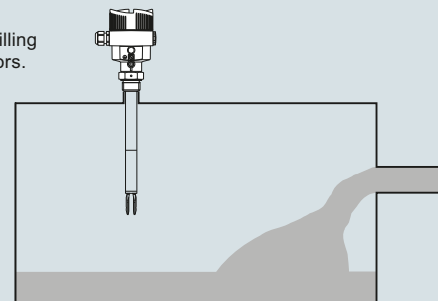

Moisture protection

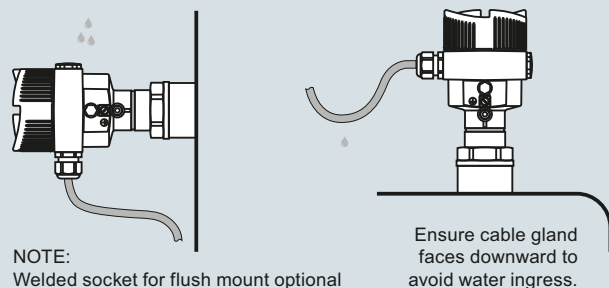

SITRANS LVL200 installation, dimensions in mm (inch)

Level measurement

Point level measurement

Vibrating switches

SITRANS LVL200

Technical specifications

Mode of operation		Design	
Measuring principle	Vibrating point level switch	Material	<ul style="list-style-type: none"> Aluminum die-cast AlSi10Mg, powder-coated, basis: Polyester Stainless steel housing, electropolished 316L Stainless steel housing, precision casting 316L Plastic housing, plastic PBT (Polyester)
Input		• Enclosure	
Measured variable	High and low and demand (via mode switch)	• Tuning fork	316L (1.4404 or 1.4435), Alloy C22
Output		• Extension tube [ø 21.3 mm (0.839 inch)]	316L (1.4404 or 1.4435), Alloy C22
Output options	<ul style="list-style-type: none"> Relay output (DPDT), 2 floating SPDTs Contactless electronic switch 2-wire Namur signal output Transistor (NPN/PNP) 10 ... 55 V DC 8/16 mA 	• Process connection: threaded	<ul style="list-style-type: none"> Standard, Extended: 316L (1.4404 or 1.4435), Alloy C22 High temperature: Inconel 718
Measuring accuracy		• Process connection: flange	<ul style="list-style-type: none"> Standard, Extended: 316L (1.4404 or 1.4435), Alloy C22 High temperature: Inconel 718
Repeatability	0.1 mm (0.004 inch)	• Process seal	316L (1.4404 or 1.4435), 316L with Alloy C22, ECTFE, or PFA coating
Hysteresis	Approx. 2 mm (0.08 inch) with vertical installation	• Process connection: threaded	Klingsil C-4400
Switching delay	<ul style="list-style-type: none"> Standard, Extended: approx. 500 ms (on/off) High temperature: approx. 1 s (optionally adjustable at factory) 	Process connection	
Frequency	<ul style="list-style-type: none"> Standard, Extended: Approx. 1 200 Hz High temperature: 1400 Hz 	• Pipe thread, cylindrical (ISO 228 T1)	G ¾" A, G 1" A
Rated operating conditions		• Pipe thread, tapered	¾" NPT, 1" NPT, 1½" NPT
Installation conditions		• Flanges	DIN from DN 25, ASME from 1"
• Location	Indoor/outdoor	• Hygienic fittings	Bolting DN 40 PN 40, 1, 1½, 2, 2½" Tri-Clamp PN 10, conus DN 25 PN 40, Tuchenhagen Varivent DN 50 PN 10, SMS
Ambient conditions		Degree of protection	Type 4X/NEMA 4X/IP66/IP67
• Ambient temperature	-40 ... +70 °C (-40 ... +158 °F)	Conduit entry	<ul style="list-style-type: none"> 1 x M20 x 1.5 (cable: ø 5 ... 9 mm), 1 x blind stopper M20 x 1.5; attached 1 x M20 x 1.5 cable entry 1 x ½" NPT cable entry, 1 x blind stopper ½" NPT, 1 x ½" NPT cable entry 1 x M12 x 1; 1 x blind stopper M20 x 1.5
• Storage temperature	-40 ... +80 °C (-40 ... +176 °F)	Weight	
• Installation category	III	• Device weight (dependent on process fitting)	Approx. 0.8 ... 4 kg (0.18 ... 8.82 lb)
• Pollution degree	2	• Tube extension (extended version)	Approx. 920 g/m (10 oz/ft)
Medium conditions		Power supply	
• Temperature		Supply voltage	20 ... 253 V AC, 50/60 Hz, 20 ... 72 V DC
- LVL200S Standard	-50 ... +150 °C (-58 ... +302 °F)	• Relay DPDT	20 ... 253 V AC, 50/60 Hz, 20 ... 253 V DC
- LVL200S High temperature option	-50 ... +250 °C (-58 ... +482 °F)	• Contactless	
- LVL200E Standard: with 316L/Alloy C22	-50 ... +150 °C (-58 ... +302 °F)	• 2-wire NAMUR	
- LVL200E High temperature option with 316L/Alloy C22	-50 ... +250 °C (-58 ... +482 °F)	Operating voltage (characteristics according to standard) for connection to an amplifier according to NAMUR	IEC 60947-5-6, approx. 8.2 V Off-load voltage U_0 approx. 8.2 V Short-circuit current I_U approx. 8.2 mA
- LVL200H High temperature	-196 ... +450 °C (-321 ... +842 °F)	Operating voltage 8/16 mA (via the signal conditioning instrument)	
Pressure (vessel)	<ul style="list-style-type: none"> Standard, Extended: -1 ... 64 bar g (-14.5 ... 928 psi g) High temperature: instrument version up to 160 bar (2 320 psi g): -1 ... 160 bar/-100 ... 16 000 kPa (-14.5 ... 2 320 psi g) <p>Note: The process pressure is dependent on configuration, including process fitting, e.g. flange</p>	• Non-Ex instrument	12 ... 36 V DC
Density	0.7 ... 2.5 g/cm ³ (0.025 ... 0.09 lb/in ³); 0.5 ... 2.5 g/cm ³ (0.018 ... 0.09 lb/in ³) by switching over Density optionally starts at 0.47 cm ³ (0.017 lb/in ³)	• Ex-d instrument (ATEX, FM, CSA)	12 ... 36 V DC
		• Ex-ia instrument (ATEX)	12 ... 29 V DC
		• Ex-ia instrument (FM, CSA)	12 ... 31 V DC

Technical specifications (continued)

Power consumption	<ul style="list-style-type: none"> Standard, Extended: 1 ... 8 VA (AC), approx. 1.3 W (DC) High temperature: 3 VA (AC), 1 W (DC)
<ul style="list-style-type: none"> Relay DPDT Contactless 	<p>1 ... 8 VA (AC), approx. 1.3 W (DC)</p> <p>Domestic current requirement approx. 3 mA (via load circuit)</p> <p>Load current</p> <ul style="list-style-type: none"> Min. 10 mA Max. 400 mA [with I > 300 mA the ambient temperature can be max. 60 °C (140 °F)] Max. 4 A up to 40 ms (not WHG specified)
<ul style="list-style-type: none"> 8/16 mA, two-wire output 	<p>Output signal</p> <ul style="list-style-type: none"> Empty (uncovered) <ul style="list-style-type: none"> - 8 mA Full (covered) <ul style="list-style-type: none"> - 16 mA Fault message <ul style="list-style-type: none"> - < 1.8 mA <p>Possible signal conditioning instruments: SITRANS SCSC, SITRANS TCSC</p>
<ul style="list-style-type: none"> 2-wire Namur 	<p>Current consumption</p> <ul style="list-style-type: none"> Falling characteristics ≥ 2.6 mA uncovered/≤ 0.6 mA covered ≤ 0.6 mA uncovered/≥ 2.6 mA covered Failure message ≤ 0.6 mA
<ul style="list-style-type: none"> Transistor (NPN/PNP) 10 ... 55 V DC 	<p>Output</p> <ul style="list-style-type: none"> Floating transistor output, permanently shortcircuit-proof <p>Load current</p> <ul style="list-style-type: none"> < 400 mA <p>Voltage loss</p> <ul style="list-style-type: none"> < 1 V <p>Switching voltage</p> <ul style="list-style-type: none"> < 55 V DC <p>Blocking current</p> <ul style="list-style-type: none"> < 10 μA
Certificates and approvals	<ul style="list-style-type: none"> CE, CSA Overfill Protection WHG and VLAREM II FM (Non-Incendive) Class I, Div. 2, Groups A, B, C, D FM (Explosion-Proof) Class I, Div. 1, Groups A, B, C, D; (Dust Ignition-Proof) Class II, III, Div. 1, Groups E, F, G1 IECEX d IIC T6 ... T2 Ga/Gb EHEDG ATEX II 1/2G, 2G EEx d IIC T6 ATEX II 1G, 1/2G, 2G EEx ia IIC T6 Shipping approvals BR-Ex d IIC T6 ... T2 FDA, 3A, EHEDG SIL/IEC61508 Declaration of Conformity [SIL-2 (min/max detection)] <p>Please see configuration section below for full list of approvals.</p>

Level measurement

Point level measurement

Vibrating switches

SITRANS LVL200

Selection and ordering data

Article No.

Article No.

SITRANS LVL200 Vibrating point level switch, standard design

Detects level and material in liquids and slurries. Short insertion. For hazardous applications.

➤ Click on the Article No. for the online configuration in the PIA Life Cycle Portal.

Electronics

Contactless electronic switch
20 ... 250 V AC/DC¹⁹⁾²⁴⁾

Double relay (DPDT)
20 ... 72 V DC/20 ... 250 V AC²⁴⁾

NAMUR signal⁹⁾

Transistor (NPN/PNP) 10 ... 55 V DC¹⁾²⁵⁾

Two-wire (8/16 mA) 12 ... 36 V DC²⁷⁾

Approvals

CE

Overfill protection (WHG)⁹⁾

ATEX II 1G, ½G, 2G Ex ia IIC T6⁶⁾

ATEX II 1G, ½G, 2G Ex ia IIC T6 + WHG⁶⁾⁹⁾

ATEX II ½G, 2G Ex d IIC T6 + WHG⁵⁾¹⁵⁾

ATEX II 1G, ½G,
2G Ex ia IIC T6 + shipping approvals⁶⁾¹⁶⁾

ATEX II ½G,
2G Ex d IIC T6 + shipping approvals⁵⁾¹⁵⁾

ATEX II 1G, ½G,
2G Ex ia IIC T6 + ATEX II ½D IP6X T⁶⁾⁷⁾¹⁷⁾

IECEx Ex ia IIC T6⁶⁾¹⁸⁾

Shipping approvals¹⁶⁾

ATEX II 3G Ex nA II T5 ... T1 X¹⁴⁾¹⁹⁾

FM (IS) Class I, II, III, Div. 1,
Groups A, B, C, D, E, F, G⁶⁾²⁰⁾

FM (XP) Class I, Div. 1, Groups A, B, C, D;
(DIP) Class II, III, Div. 1, Groups E, F, G²⁾⁵⁾¹⁰⁾

FM (NI) Class I, Div. 2, Groups A, B, C, D,
CE²¹⁾

IECEx d IIC T6 ... T2 Ga/Gb⁵⁾¹⁵⁾

CSA (XP) Class I, II, III Div. 1,
Groups A, B, C, D, E, F, G⁵⁾¹⁵⁾

CSA (NI) Class I, II, III, Div. 2,
Groups A, B, C, D, E, F, G, CE²²⁾

BR-Ex d IIC T6 ... T2⁵⁾²³⁾

CSA (IS) Class I, II, III Div. 1,
Groups A, B, C, D, E, F, G⁶⁾⁹⁾

ATEX II ½D, 2D ExtD A20/21,
A21 IP6 T...⁶⁾¹⁹⁾

GOST-R/EAC + ATEX II 1G, ½G,
2G Ex ia IIC T6 + WHG⁹⁾²⁶⁾

GOST-R/EAC + ATEX II ½G,
Ex d IIC T2 ... T6 + WHG⁵⁾¹⁵⁾²⁸⁾

GOST-R/EAC + ATEX II ½G,
Ex d IIC T2 ... T6 + Ship approval⁵⁾¹⁵⁾²⁸⁾

GOST-R/EAC + ATEX II 1G, ½G,
2G Ex ia IIC T6 + II ½D, 2D ExtD⁷⁾¹⁷⁾²⁸⁾

GOST-R/EAC + ATEX II ½D,
2D ExtD A20/21, A21 IP6 T...¹⁷⁾²⁶⁾

Process connection

Thread G¾" A, PN 64/316L **A 0 0**

Thread G¾" A, PN 64/316L Ra < 0.8 µm **A 0 1**

Thread ¾" NPT, PN 64/316L **A 0 2**

Thread ¾" NPT, PN 64/316L Ra < 0.8 µm **A 0 3**

Thread ¾" NPT, PN 64/Alloy 400 (2.4360) **A 0 4**

Thread G¾" A, PN 64/Alloy C22 (2.4602) **A 0 5**

Thread ¾" NPT, PN 64/Alloy C22 (2.4602) **A 0 6**

Thread G1" A, PN 64/316L **A 0 7**

Thread G1" A, PN 64/316L **A 0 8**

ECTFE coated MB1982⁴⁾

Thread G1" A, PN 64/316L PFA coated⁴⁾ **A 1 0**

Thread G1" A, PN 64/Alloy 400 (2.4360) **A 1 1**

Thread G1" A, PN 64/316L Ra < 0.8 µm **A 1 2**

Thread 1" NPT, PN 64/316L **A 1 3**

Thread 1" NPT, PN 64/316L **A 1 4**

ECTFE coated MB1982⁴⁾

SITRANS LVL200 Vibrating point level switch, standard design

Detects level and material in liquids and slurries. Short insertion. For hazardous applications.

Thread 1" NPT, PN 64/316L PFA-coated⁴⁾ **A 1 5**

Thread 1" NPT, PN 64/Alloy 400 (2.4360) **A 1 6**

Thread 1" NPT, PN 64/316L Ra < 0.8 µm **A 1 7**

Thread G1" A, PN 64/Alloy C22 (2.4602) **A 1 8**

Thread G1" A, PN 64/Alloy C22 (2.4602) **A 2 0**

Ra < 0.3 µm

Thread G1½" A, PN 64/316L **A 2 1**

Thread G1½" A, PN 64/316L Ra < 0.8 µm **A 2 2**

Thread G1½" A, PN 64/Alloy C22 (2.4602) **A 2 3**

Thread 1" NPT, PN 64/Alloy C22 (2.4602) **A 2 4**

Thread 1½" NPT, PN 64/316L **A 2 5**

Thread 1½" NPT, PN 64/316L Ra < 0.8 µm **A 2 6**

Thread 1½" NPT, PN 64/Alloy C22 (2.4602) **A 2 7**

Thread G2" A, PN 64/316L **A 2 8**

Thread M27 x 1.5, PN 64/316L **A 3 0**

Conus DN 25, PN 40/316L Ra < 0.3 µm **A 3 1**

Conus DN 25, PN 40/316L Ra < 0.8 µm **A 3 2**

Conus DN 25, PN 40/ECTFE (ZB3033)⁴⁾ **A 3 3**

Conus M52, PN 40/316L **A 3 4**

Conus M52, PN 40/316L Ra < 0.3 µm **A 3 5**

Conus M52, PN 40/316L Ra < 0.8 µm **A 3 6**

Tri-Clamp 1", PN 16/316L Ra < 0.3 µm **A 3 7**

Tri-Clamp 1", PN 16/Alloy C22 (2.4602) **A 3 8**

Tri-Clamp 1", PN 16/316L Ra < 0.8 µm **A 4 0**

Tri-Clamp 1½", PN 16/316L Ra < 0.3 µm **A 4 1**

Tri-Clamp 1½", PN 16/Alloy C22 (2.4602) **A 4 2**

Tri-Clamp 1½", PN 16/316L Ra < 0.8 µm **A 4 3**

Tri-Clamp 2", PN 16/316L Ra < 0.3 µm **A 4 4**

Tri-Clamp 2", PN 16/Alloy C22 (2.4602) **A 4 5**

Tri-Clamp 2", PN 16/316L Ra < 0.8 µm **A 4 6**

Tri-Clamp 2½", PN 10/316L Ra < 0.3 µm **A 4 7**

Tri-Clamp 2½", PN 10/316L Ra < 0.8 µm **A 4 8**

Tri-Clamp 3", PN 10/316L Ra < 0.3 µm **A 5 0**

Tri-Clamp 3", PN 10/316L Ra < 0.8 µm **A 5 1**

Bolting DN 32, PN 40 DIN11851/316L Ra < 0.3 µm **A 5 2**

Bolting DN 32, PN 40 DIN11851/316L Ra < 0.8 µm **A 5 3**

Bolting DN 25, PN 40 DIN11851/316L Ra < 0.3 µm **A 5 4**

Bolting DN 25, PN 40 DIN11851/316L Ra < 0.8 µm **A 5 5**

Bolting DN 40, PN 40 DIN11851/316L Ra < 0.3 µm **A 5 6**

Bolting DN 40, PN 40 DIN11851/316L Ra < 0.8 µm **A 5 7**

Bolting DN 40, PN 40 DIN11864-1 A/316L Ra < 0.8 µm ZB3052 **A 5 8**

Bolting DN 50, PN 25 DIN11851/316L Ra < 0.3 µm **A 6 0**

Bolting DN 50, PN 25 DIN11851/316L Ra < 0.8 µm **A 6 1**

Bolting DN 50, PN 25 DIN11864-1 A/316L Ra < 0.8 µm ZB3052 **A 6 2**

Hygienic w. compr. nut F40, PN 25/316L **A 6 3**

Hygienic w. compr. nut F40, PN 25/316L Ra < 0.3 µm **A 6 4**

Hygienic w. compr. nut F40, PN 25/316L Ra < 0.8 µm **A 6 5**

Varivent N50-40/316L Ra < 0.3 µm **A 6 6**

Varivent N50-40/316L Ra < 0.8 µm **A 6 7**

Varivent N125/100/316L Ra < 0.8 µm **A 6 8**

DRD flange, PN 40/316L ZB3007 **A 7 0**

SMS DN 38/316L Ra < 0.8 µm⁴⁾ **A 7 1**

SMS DN 51, PN 6/316L Ra < 0.8 µm⁴⁾ **A 7 2**

Swagelok VCR screwing ZG2579, PN 64/316L **A 7 3**

Neumo biocontrol size 25, PN 16/316L Ra < 0.8 µm **A 7 4**

Selection and ordering data	Article No.	Article No.
SITRANS LVL200 Vibrating point level switch, standard design	7ML5746-	7ML5746-
Detects level and material in liquids and slurries. Short insertion. For hazardous applications.	- A 0	- A 0
Neumo biocontrol size 50, PN 16/316L Ra < 0.8 µm ⁴⁾	A 7 5	B 3 0
Neumo biocontrol size 65, PN 16/316L Ra < 0.8 µm	A 7 6	B 3 1
Neumo biocontrol size 80, PN 16/316L Ra < 0.8 µm	A 7 7	B 3 2
SÜDMO DN 50, PN 10/316L Ra < 0.8 µm	A 7 8	B 3 3
Small flange DN 25, PN 1.5 DIN 28403/316L pol. Ra < 0.8 µm	A 8 0	B 3 4
Small flange DN 40, PN 1.5 DIN 28403/316L pol. Ra < 0.8 µm	A 8 1	B 3 5
Ingold connection, PN16/316L a < 0.8 µm (acc. to MB2523)	A 8 2	B 3 6
Ingold connection, PN 16/Alloy C22 (2.4602) Ra < 0.8 µm (acc. to MB6017)	A 8 3	B 3 7
Terminal DN 33.7 PN 40 DIN 11864-3-A-/316L BN2 Ra < 0.8 µm ⁴⁾	A 8 4	B 3 8
Hygienic fl. DN 50 PN 16 DIN 11864-2-A-/316L Ra < 0.8 µm	A 8 5	B 4 0
Flange DN 25, PN 6 Form C, DIN 2501/316L	A 8 6	B 4 1
Flange DN 25, PN 6 Form C, DIN 2501/PFA ⁴⁾	A 8 7	B 4 2
Flange DN 25, PN 40 Form C, DIN 2501/316L	A 8 8	B 4 3
Flange DN 25, PN 40 Form C, DIN 2501/Alloy C22 (2.4602)	B 0 0	B 4 4
Flange DN 25, PN 40 Form C, DIN 2501/ECTFE ⁴⁾	B 0 1	B 4 5
Flange DN 25, PN 40 Form C, DIN 2501/PFA ⁴⁾	B 0 2	B 4 6
Flange DN 25, PN 40 Form C, DIN 2501/Enamelled	B 0 3	B 4 7
Flange DN 25, PN 40 Form D, DIN 2501/316L	B 0 4	B 4 8
Flange DN 25, PN 40 Form F, DIN 2501/316L	B 0 5	B 5 0
Flange DN 25, PN 40 Form N, DIN 2501/316L	B 0 6	B 5 1
Flange DN 25, PN 40 Form N, DIN 2501/Alloy C22 (2.4602)	B 0 7	B 5 2
Flange DN 25, PN 40 Form N, DIN 2501/Alloy 400 (2.4360) solid	B 0 8	B 5 3
Flange DN 25, PN 40 V13, DIN 2501/316L	B 1 0	B 5 4
Flange DN 32, PN 40 Form C, DIN 2501/316L	B 1 1	B 5 5
Flange DN 32, PN 40 Form C, DIN 2501/ECTFE ⁴⁾	B 1 2	B 5 6
Flange DN 40, PN 6 Form C, DIN 2501/316L	B 1 3	B 5 7
Flange DN 40, PN 6 Form C, DIN 2501/ECTFE ⁴⁾	B 1 4	B 5 8
Flange DN 40, PN 40 Form C, DIN 2501/316L	B 1 5	B 6 0
Flange DN 40, PN 40 Form C, DIN 2501/Alloy C22 (2.4602)	B 1 6	B 6 2
Flange DN 40, PN 40 Form C, DIN 2501/ECTFE ⁴⁾	B 1 7	B 6 3
Flange DN 40, PN 40 Form C, DIN 2501/PFA ⁴⁾	B 1 8	B 6 4
Flange DN 40, PN 40 Form C, DIN 2501/Enamelled ³⁾	B 2 0	B 6 5
Flange DN 40, PN 40 Form F, DIN 2501/316L	B 2 1	B 6 6
Flange DN 40, PN 40 Form N, DIN 2501/316L	B 2 2	B 6 7
Flange DN 40, PN 40 Form E, DIN 2501/316L	B 2 3	B 6 8
Flange DN 40, PN 40 V13, DIN 2501/316L	B 2 4	B 7 0
Flange DN 50, PN 40 Form C, DIN 2501/316L	B 2 5	B 7 1
Flange DN 50, PN 40 Form C, DIN 2501/Alloy C22 (2.4602)	B 2 6	B 7 2
Flange DN 50, PN 40 Form C, DIN 2501/ECTFE ⁴⁾	B 2 7	B 7 3
Flange DN 50, PN 40 Form C, DIN 2501/PFA ⁴⁾	B 2 8	
Flange DN 50, PN 40 Form C, DIN 2501/Alloy C22 (2.4602)		
Flange DN 50, PN 40 Form D, DIN 2501/316L		
Flange DN 50, PN 40 Form D, DIN 2501/Alloy C22 (2.4602)		
Flange DN 50, PN 40 Form F, DIN 2501/316L		
Flange DN 50, PN 40 Form N, DIN 2501/316L		
Flange DN 50, PN 40 Form N, DIN 2501/Alloy C22 (2.4602)		
Flange DN 50, PN 40 Form E, DIN 2501/316L		
Flange DN 50, PN 40 V13, DIN 2501/316L		
Flange DN 50, PN 40 R13, DIN 2501/316L		
Flange DN 50, PN 64 Form F, DIN 2501/316L		
Flange DN 50, PN 64 Form N, DIN 2501/Alloy C22 (2.4602)		
Flange DN 50, PN 64 Form C, DIN 2501/316L		
Flange DN 50, PN 64 Form L, DIN 2501/316L		
Flange DN 50, PN 100 Form E, DIN 2501/316L		
Flange DN 50, PN 100 Form L, DIN 2501/316L		
Flange DN 65, PN 40 Form C, DIN 2501/316L		
Flange DN 65, PN 40 Form C, DIN 2501/Alloy C22 (2.4602)		
Flange DN 65, PN 40 Form C, DIN 2501/ECTFE ⁴⁾		
Flange DN 65, PN 40 Form C, DIN 2501/PFA ⁴⁾		
Flange DN 65, PN 40 Form F, DIN 2501/316L		
Flange DN 65, PN 64 Form E, DIN 2501/316L		
Flange DN 80, PN 40 Form C, DIN 2501/316L		
Flange DN 80, PN 40 Form C, DIN 2501/Alloy C22 (2.4602)		
Flange DN 80, PN 40 Form C, DIN 2501/ECTFE ⁴⁾		
Flange DN 80, PN 40 Form C, DIN 2501/PFA ⁴⁾		
Flange DN 80, PN 40 Form C, DIN 2501/Enamelled ³⁾		
Flange DN 80, PN 40 Form F, DIN 2501/316L		
Flange DN 80, PN 40 Form N, DIN 2501/316L		
Flange DN 100, PN 16 Form C, DIN 2501/316L		
Flange DN 100, PN 16 Form C, DIN 2501/Alloy C22 (2.4602)		
Flange DN 100, PN 16 Form C, DIN 2501/ECTFE ⁴⁾		
Flange DN 100, PN 16 Form C, DIN 2501/PFA ⁴⁾		
Flange DN 100, PN 16 Form C, DIN 2501/Enamelled ³⁾		
Flange DN 100, PN 16 Form D, DIN 2501/316L		
Flange DN 100, PN 16 Form F, DIN 2501/316L		
Flange DN 100, PN 16 Form N, DIN 2501/316L		
Flange DN 100, PN 40 Form C, DIN 2501/316L		
Flange DN 100, PN 40 Form C, DIN 2501/ECTFE ⁴⁾		
Flange DN 100, PN 40 Form C, DIN 2501/PFA ⁴⁾		

Level measurement

Point level measurement

Vibrating switches

SITRANS LVL200

Selection and ordering data

Article No.

Article No.

SITRANS LVL200 Vibrating point level switch, standard design

Detects level and material in liquids and slurries. Short insertion. For hazardous applications.

	7ML5746-
Flange DN 100, PN 40 Form C, DIN 2501/Enamelled ³⁾	B 7 4
Flange DN 100, PN 40 Form F, DIN 2501/316L	B 7 5
Flange DN 100, PN 40 Form N, DIN 2501/316L	B 7 6
Flange DN 100, PN 40 V13, DIN 2501/316L	B 7 7
Flange DN 100, PN 64 Form E, DIN 2501/316L	B 7 8
Flange DN 100, PN 100 Form E, DIN 2501/316L	B 8 0
Flange DN 100, PN 100 Form L, DIN 2501/316L	B 8 1
Flange DN 125, PN 16 Form F, DIN 2501/316L	B 8 2
Flange DN 125, PN 40 Form C, DIN 2501/316L	B 8 3
Flange DN 125, PN 40 Form N, DIN 2512/316L	B 8 4
Flange DN 150, PN 16 Form C, DIN 2501/316L	B 8 5
Flange DN 150, PN 16 Form C, DIN 2501/Alloy C22 (2.4602)	B 8 6
Flange DN 150, PN 16 Form C, DIN 2501/ECTFE ⁴⁾	B 8 7
Flange DN 150, PN 16 Form C, DIN 2501/PFA ⁴⁾	B 8 8
Flange DN 150, PN 16 Form D, DIN 2501/316L	C 0 0
Flange DN 150, PN 40 Form C, DIN 2501/316L	C 0 1
Flange DN 150, PN 40 Form C, DIN 2501/Alloy C22 (2.4602)	C 0 2
Flange DN 150, PN 40 Form F, DIN 2501/316L	C 0 3
Flange DN 150, PN 40 Form N, DIN 2512/316L	C 0 4
Flange DN 200, PN 10 Form C, DIN 2501/ECTFE ⁴⁾	C 0 5
Flange DN 200, PN 16 Form C, DIN 2501/316L	C 0 6
Flange DN 25, PN 40 Form B1, EN 1092-1/316L	C 0 7
Flange DN 25, PN 40 Form B1, EN 1092-1/Alloy C22 (2.4602)	C 0 8
Flange DN 25, PN 40 Form B1, EN/316L/PFA ⁴⁾	C 1 0
Flange DN 25, PN 40 Form B1, EN 1092-1/Enamelled ³⁾	C 1 1
Flange DN 25, PN 40 Form B2, EN 1092-1/316L	C 1 2
Flange DN 25, PN 40 Form F, EN 1092-1/316L	C 1 3
Flange DN 25, PN 63 Form B1, EN 1092-1/316L	C 1 4
Flange DN 25, PN 100 Form B2, EN 1092-1/316L	C 1 5
Flange DN 40, PN 40 Form B1, EN/316L	C 1 6
Flange DN 40, PN 40 Form B1, EN 1092-1/PFA ⁴⁾	C 1 7
Flange DN 40, PN 40 Form B2, EN/316L	C 1 8
Flange DN 50, PN 40 Form B1, EN/316L	C 2 0
Flange DN 50, PN 40 Form B1, EN 1092-1/Alloy C22 (2.4602)	C 2 1
Flange DN 50, PN 40 Form B1, EN 1092-1/Alloy 400 (2.4360) ZB2977	C 2 2
Flange DN 50, PN 40 Form B1, EN 1092-1/ECTFE ⁴⁾	C 2 3
Flange DN 50, PN 40 Form B1, EN/316L/PFA ⁴⁾	C 2 4
Flange DN 50, PN 40 Form B1, EN 1092-1/Enamelled ³⁾	C 2 5

SITRANS LVL200 Vibrating point level switch, standard design

Detects level and material in liquids and slurries. Short insertion. For hazardous applications.

	7ML5746-
Flange DN 50, PN 40 Form C, EN 1092-1/316L	C 2 6
Flange DN 50, PN 40 Form D, EN/316L	C 2 7
Flange DN 50, PN 40 Form D, EN 1092-1/Alloy C22 (2.4602)	C 2 8
Flange DN 50, PN 40 Form B2, EN 1092-1/316L	C 3 0
Flange DN 50, PN 40 Form E, EN 1092-1/316L	C 3 1
Flange DN 80, PN 40 Form B1, EN 1092-1/316L	C 3 2
Flange DN 80, PN 40 Form B1, EN 1092-1/Alloy C22 (2.4602)	C 3 3
Flange DN 80, PN 40 Form B1, EN 1092-1/ECTFE ⁴⁾	C 3 4
Flange DN 80, PN 40 Form B1, EN 1092-1/Enamelled ³⁾	C 3 5
Flange DN 80, PN 40 Form B2, EN 1092-1/316L	C 3 6
Flange DN 100, PN 16 Form B1, EN 1092-1/316L	C 3 7
Flange DN 100, PN 16 Form B1, EN 1092-1/Alloy C22 (2.4602)	C 3 8
Flange DN 100, PN 16 Form B1, EN 1092-1/Enamelled ³⁾	C 4 0
Flange DN 100, PN 40 Form B1, EN 1092-1/316L	C 4 1
Flange DN 100, PN 40 Form B1, EN 1092-1/Enamelled ³⁾	C 4 2
Flange DN 100, PN 40 Form C, EN 1092-1/316L	C 4 3
Flange DN 100, PN 63 Form B2, EN 1092-1/316L	C 4 4
Flange DN 150, PN 16 Form B1, EN 1092-1/316L	C 4 5
Flange DN 150, PN 16 Form B1, EN 1092-1/PFA ⁴⁾	C 4 6
Flange DN 150, PN 40 Form B1, EN 1092-1/316L	C 4 7
Flange DN 150, PN 40 Form B1, EN 1092-1/ECTFE ⁴⁾	C 4 8
Flange DN 150, PN 40 Form B2, EN 1092-1/316L	C 5 0
Flange 1" 150 lb RF, ASME B16.5/316L	C 5 1
Flange 1" 150 lb RF, ASME B16.5/Alloy C22 (2.4602)	C 5 2
Flange 1" 150 lb RF, ASME B16.5/Alloy 400 (2.4360) ZB2977	C 5 3
Flange 1" 150 lb RF, ASME B16.5/ECTFE ⁴⁾	C 5 4
Flange 1" 150 lb RF, ASME B16.5/PFA ⁴⁾	C 5 5
Flange 1" 150 lb RF, ASME B16.5/Enamelled ³⁾	C 5 6
Flange 1" 300 lb RF, ASME B16.5/316L	C 5 7
Flange 1" 300 lb RF, ASME B16.5/ECTFE ⁴⁾	C 5 8
Flange 1" 600 lb RF, ASME B16.5/316L	C 6 0
Flange 1½" 150 lb RF, ASME B16.5/316L	C 6 1
Flange 1½" 150 lb RF, ASME B16.5/Alloy C22 (2.4602)	C 6 2
Flange 1½" 150 lb RF, ASME B16.5/ECTFE ⁴⁾	C 6 3
Flange 1½" 150 lb RF, ASME B16.5/PFA ⁴⁾	C 6 4
Flange 1½" 150 lb RF, ASME B16.5 Enamelled ³⁾	C 6 5
Flange 1½" 150 lb FF, ASME B16.5/ECTFE ⁴⁾	C 6 6
Flange 1½" 300 lb RF, ASME B16.5/316L	C 6 7
Flange 1½" 300 lb RF, ASME B16.5/Alloy 400 (2.4360) ZB2977	C 6 8
Flange 1½" 300 lb RF, ASME B16.5/ECTFE ³⁾	C 7 0
Flange 1½" 600 lb RF, ASME B16.5/316L	C 7 1
Flange 2" 150 lb RF, ASME B16.5/316L	C 7 2
Flange 2" 150 lb RF, ASME B16.5/Alloy C22 (2.4602)	C 7 3

4

Selection and ordering data	Article No.	Article No.
SITRANS LVL200 Vibrating point level switch, standard design Detects level and material in liquids and slurries. Short insertion. For hazardous applications.	7ML5746- - A 0	7ML5746- - A 0
Flange 2" 150 lb RF, ASME B16.5/Alloy 400 (2.4360) ZB2977	C 7 4	D 4 6
Flange 2" 150 lb RF, ASME B16.5/ECTFE ⁴⁾	C 7 5	D 4 7
Flange 2" 150 lb RF, ASME B16.5/PFA ⁴⁾	C 7 6	D 4 8
Flange 2" 150 lb RF, ASME B16.5/Enamelled ³⁾	C 7 7	D 5 0
Flange 2" 150 lb FF, ASME B16.5/316L	C 7 8	D 5 1
Flange 2" 150 lb FF, ASME B16.5/ECTFE ⁴⁾	C 8 0	D 5 2
Flange 2" 150 lb SG (small groove), ASME B16.5/316L	C 8 1	D 5 3
Flange 2" 300 lb RF, ASME B16.5/316L	C 8 2	D 5 4
Flange 2" 300 lb RF, ASME B16.5/Alloy C22 (2.4602)	C 8 3	D 5 5
Flange 2" 300 lb RF, ASME B16.5/ECTFE ⁴⁾	C 8 5	D 5 6
Flange 2" 300 lb RF, ASME B16.5/PFA ⁴⁾	C 8 6	D 5 7
Flange 2" 300 lb RF, ASME B16.5/Enamelled ³⁾	C 8 7	D 5 8
Flange 2" 300 lb RJF, ASME B16.5/316L	C 8 8	D 6 0
Flange 2" 300 lb ST, ASME B16.5/316L	D 0 0	D 6 1
Flange 2" 300 lb LG (large groove), ASME B16.5/316L	D 0 1	D 6 2
Flange 2" 300 lb LT, ASME B16.5/316L	D 0 2	D 6 3
Flange 2" 600 lb RF, ASME B16.5/316L	D 0 3	D 6 5
Flange 2" 600 lb RF, ASME B16.5/Alloy 400 (2.4360) ZB2977	D 0 4	D 7 0
Flange 2" 600 lb RF, ASME B16.5/ECTFE ⁴⁾	D 0 5	
Flange 2" 600 lb RJF, ASME B16.5/316L	D 0 6	
Flange 2" 600 lb LG, ASME B16.5/316L	D 0 7	
Flange 2" 900 lb RJF, ASME B16.5/316L	D 0 8	
Flange 2½" 150 lb RF, ASME B16.5/316L	D 1 0	
Flange 2½" 300 lb RF, ASME B16.5/316L	D 1 1	
Flange 3" 150 lb RF, ASME B16.5/316L	D 1 2	
Flange 3" 150 lb RF, ASME B16.5/Alloy C22 (2.4602)	D 1 3	
Flange 3" 150 lb RF, ASME B16.5/ECTFE ⁴⁾	D 1 4	A
Flange 3" 150 lb RF, ASME B16.5/PFA ⁴⁾	D 1 5	B
Flange 3" 150 lb RF, ASME B16.5/Enamelled ³⁾	D 1 6	C
Flange 3" 150 lb FF, ASME B16.5/316L	D 1 7	D
Flange 3" 150 lb FF, ASME B16.5/ECTFE ⁴⁾	D 1 8	E
Flange 3" 150 lb FF, ASME B16.5/PFA ⁴⁾	D 2 0	F
Flange 3" 300 lb RF, ASME B16.5/316L	D 2 1	G
Flange 3" 300 lb RF, ASME B16.5/Alloy C22 (2.4602)	D 2 2	H
Flange 3" 300 lb RF, ASME B16.5/ECTFE ⁴⁾	D 2 3	V
Flange 3" 300 lb RF, ASME B16.5/PFA ⁴⁾	D 2 4	
Flange 3" 300 lb RF, ASME B16.5/Enamelled ³⁾	D 2 5	
Flange 3" 600 lb RF, ASME B16.5/316L	D 2 6	
Flange 3½" 150 lb RF, ASME B16.5/316L	D 2 7	
Flange 3½" 150 lb RF, ASME B16.5/ECTFE ⁴⁾	D 2 8	
Flange 4" 150 lb RF, ASME B16.5/316L	D 3 0	
Flange 4" 150 lb RF, ASME B16.5/Alloy C22 (2.4602)	D 3 1	
Flange 4" 150 lb RF, ASME B16.5/ECTFE ⁴⁾	D 3 2	
Flange 4" 150 lb RF, ASME B16.5/PFA ⁴⁾	D 3 3	
Flange 4" 150 lb RF, ASME B16.5/Enamelled ³⁾	D 3 4	
Flange 4" 150 lb LT, ASME B16.5/316L	D 3 5	
Flange 4" 300 lb RF, ASME B16.5/316L	D 3 6	
Flange 4" 300 lb RF, ASME B16.5/Alloy C22 (2.4602)	D 3 7	
Flange 4" 300 lb RF, ASME B16.5/ECTFE ⁴⁾	D 3 8	
Flange 4" 300 lb RJF, ASME B16.5/316L	D 4 0	
Flange 4" 300 lb LG, ASME B16.5/316L	D 4 1	
Flange 4" 300 lb LT, ASME B16.5/316L	D 4 2	
Flange 4" 600 lb RF, ASME B16.5/316L	D 4 3	
Flange 4" 600 lb RJF, ASME B16.5/316L	D 4 4	
Flange 6" 150 lb RF, ASME B16.5/316L	D 4 5	
SITRANS LVL200 Vibrating point level switch, standard design Detects level and material in liquids and slurries. Short insertion. For hazardous applications.		
Flange 6" 150 lb RF, ASME B16.5/Alloy C22 (2.4602)		
Flange 6" 150 lb RF, ASME B16.5/ECTFE ⁴⁾		
Flange 6" 150 lb RF, ASME B16.5/PFA ⁴⁾		
Flange 6" 150 lb RJF, ASME B16.5/316L		
Flange 6" 300 lb RF, ASME B16.5/316L		
Flange 8" 150 lb RF, ASME B16.5/316L		
Flange 8" 150 lb RF, ASME B16.5/ECTFE ⁴⁾		
Flange 1" BS.10 Table E/316L		
Flange 1" BS.10 Table E/PFA ⁴⁾		
Flange 1½" BS.10 Table E/316L		
Flange 3½" BS.10 Table E/316L		
Flange 4" BS.10 Table E/ECTFE ⁴⁾		
Flange DN 40 10K, JIS/316L		
Flange DN 50 10K, JIS/316L		
Flange DN 80 10K, JIS/316L		
Flange DN 100 10K, JIS/316L		
Thread R1 PN 64, EN 10226-1/316L		
Flange 2" 900 lb RF, ASME B16.5/316L		
Adapter/Process temperature Without adapter/-50 ... +150 °C (-58 ... +302 °F) With adapter/-50 ... +200 °C (-58 ... +392 °F) ¹³⁾ With adapter/-50 ... +250 °C (-58 ... +482 °F) With gas-tight leadthrough/-50 ... +150 °C (-58 ... +302 °F) With gas-tight leadthrough/-50 ... +250 °C (-58 ... +482 °F)		1 2 3 4 5
Housing/Cable entry Aluminum IP66/IP67/M20 x 1.5 Aluminum IP66/IP67/½" NPT 316L stainless steel (electropolished) IP66/IP67/M20 x 1.5 316L stainless steel (electropolished) IP66/IP67/½" NPT Plastic single chamber IP66/IP67/M20 x 1.5 Plastic single chamber IP66/IP67/½" NPT Stainless steel chamber (precision casting) IP66/IP67/M20 x 1.5 Stainless steel chamber (precision casting) IP66/IP67/½" NPT Aluminum IP66/IP67/M20 x 1.5 Special HARTING plug HAN 7D (bent) according to Tier One (ZB7555) ¹¹⁾		A B C D E F G H V

Level measurement

Point level measurement

Vibrating switches

SITRANS LVL200

Selection and ordering data	Order code	Article No.
Further designs		Spare Parts and Accessories
Please add -Z to Article No. and specify Order code(s).		Electronics module SITRANS LVL200 Relay 7ML1830-1NC
Switching status indication with colors red-green ¹²⁾	A21	Electronics module SITRANS LVL200 Contactless 7ML1930-6AA
Cleaning including Certificate (oil, grease, and silicone free)	W01	NAMUR spare electronics module A5E35817107
Identification label (measurement loop) stainless steel: max. 40 characters, add in plain text. To add more than one line, use a coma ", " for line break.	Y17	SITRANS SCSC single channel signal conditioner and remote test 7ML5760-.....-....
Identification Label (measurement loop) foil: max. 40 characters add in plain text. To add more than one line, use a coma ", " for line break.	Y18	SITRANS TCSC two channel signal conditioner and remote test 7ML5761-.....-....
NACE0175 to 3.1 Material Certificate for material (EN10204 NACE MR 0175) ⁸⁾ Note: not available with Process Connection and Rigid extension coatings PFA, ECTFE, and Enamel. NACE not available with Hygienic process connections.	D07	<u>LVL200 Threaded Welded Socket</u>
Material Inspection certificate 3.1 of EN 10204 ⁸⁾	C05	• G¾" A/316L with FKM Seal 7ML1930-1EE
2.2-Factory certificate for material (EN 10204) ⁸⁾	C15	• G1" A/316L with FKM Seal 7ML1930-1EF
Functional Safety (SIL 2). Device suitable for use in accordance with IEC 61508 and IEC 61511 ⁸⁾	C20	• M27 x 1.5/316L with FKM Seal 7ML1930-1EG
Dye penetration test, results confirmed via a 3.1 certificate/instrument (EN 10204) ⁸⁾	C13	• G¾" A/316L with EPDM Seal 7ML1930-1EH
X-ray test + 3.1 certificate/instrument ⁸⁾	C14	• G1" A/316L with EPDM Seal 7ML1930-1EJ
Positive material identification test + 3.1 certificate/instrument ⁸⁾	C16	• M27 x 1.5/316L with EPDM Seal 7ML1930-1EK
Roughness test + 3.1 certificate/instrument ⁸⁾	C18	
3.1-Inspection Certificate for instrument with test data (EN 10204) ⁸⁾	C25	
Quality and test plan	C26	
Factory declaration 2.1 (EN 10204) - certificate suitable for tropical regions with all attachment parts of metal	C65	
Inspection certificate 3.1 (EN 10204) - device and pressure test ⁸⁾	C31	
Helium leak test + 3.1 certificate/instrument ⁸⁾	C32	
Ferrite measuring accuracy to DIN 32514-1 + 3.1 certificate/instrument ⁸⁾	C60	
Pressure test according to Norsok + 3.1 certificate/instrument ⁸⁾	C61	
Operating Instructions		
All literature is available to download for free, in a range of languages, at http://www.siemens.com/processinstrumentation/documentation		
		<ol style="list-style-type: none"> 1) Available only with Adapter/Process temperature options 1, 3, 4, and 5. 2) Available only with Housing/Protection/Cable option B. 3) Available only with Adapter/Process Temperature options 1, 2, and 4. 4) Not available with Adapter/Process Temperature options 2, 3, and 5. 5) Not available with Adapter/Process Temperature options 2, 4, and 5. 6) Available only with Electronics options 4 and 6. 7) Not available with ECTFE coated probe options. 8) Listed Certificates are not available with all configurations please contact factory for more information. 9) Not available with Housing/Protection/Cable Option V. 10) Not available with PFA and ECTFE coating options. 11) Available only with Approval option A. 12) Available only with Relay Electronic options and Non-hazardous Approval options. 13) Available only with Enamelled Process connection options. 14) Available only with Electronic options 4, 5, and 6. 15) Available only with Aluminum Housing/Protection/Cable options. 16) Not available with Stainless Steel (electropolished) Housing/Protection/Cable options and certain glands. 17) Not available with Plastic and Stainless Steel (electropolished) Housing/Protection/Cable options and certain glands. 18) Not available with Housing/Protection/Cable options D, and V. 19) Not available with Plastic Housing/Protection/Cable options and certain glands. 20) Not available with Housing/Protection/Cable options A, E, G, and V. 21) Available only with Housing/Protection/Cable options B, D, F, and H. 22) Not available with Housing/Protection/Cable options C and V. 23) Available only with Housing/Protection/Cable options A, B, and H. 24) Not available with Approval options C, E, G, H, L, N, V, W, J1A, J1D, and J1E. 25) Not available with Approval options C, E, G, H, N, V, W, J1A, J1D, and J1E. 26) Available only with Electronic option 4. 27) Not available with EAC approval options. 28) Not available with Electronic option 6.

Selection and ordering data	Article No.	Article No.
<p>SITRANS LVL200 Vibrating point level switch, rigid extension design</p> <p>Detects level and material in liquids and slurries. Top mount, with extension options to 6 m (19.69 ft). Ideal for hazardous applications.</p> <p>➤ Click on the Article No. for the online configuration in the PIA Life Cycle Portal.</p>	7ML5747-	7ML5747-
<p>Electronics</p> <p>Contactless electronic switch 20 ... 250 V AC/DC¹⁾⁹⁾¹⁴⁾</p> <p>Double relay (DPDT) 20 ... 72 V DC/20 ... 250 V AC¹⁴⁾</p> <p>NAMUR signal⁹⁾</p> <p>Transistor (NPN/PNP) 10 ... 55 V DC¹⁾¹⁵⁾</p> <p>Two-wire (8/16 mA) 12 ... 36 V DC²⁵⁾</p>	1 2 4 5 6	
<p>Approvals</p> <p>CE</p> <p>Overfill protection (WHG)⁹⁾</p> <p>ATEX II 1G, ½G, 2G Ex ia IIC T6⁶⁾</p> <p>ATEX II 1G, ½G, 2G Ex ia IIC T6 + WHG⁶⁾⁹⁾</p> <p>ATEX II ½G, 2G Ex d IIC T6 + WHG⁵⁾⁷⁾¹⁶⁾</p> <p>ATEX II 1G, ½G, 2G Ex ia IIC T6 + shipping approvals⁵⁾¹⁷⁾</p> <p>ATEX II ½G, 2G Ex d IIC T6 + shipping approvals⁵⁾⁷⁾¹⁶⁾</p> <p>ATEX II 1G, ½G, 2G Ex ia IIC T6 + ATEX II ½D IP6X T⁶⁾⁸⁾¹⁸⁾</p> <p>IECEx Ex ia IIC T6⁶⁾¹⁹⁾</p> <p>Shipping approvals¹⁷⁾</p> <p>ATEX II 3G Ex nA II T5 ... T1 X</p> <p>FM (IS) Class I, II, III, Div. 1, Groups A, B, C, D, E, F, G⁶⁾²⁰⁾</p> <p>FM (XP) Class I, Div. 1, Groups A, B, C, D; (DIP) Class II, III, Div. 1, Groups E, F, G²⁾⁵⁾</p> <p>FM (NI) Class I, Div. 2, Groups A, B, C, D, CE²¹⁾</p> <p>IECEx d IIC T6 ... T2 Ga/Gb⁵⁾⁷⁾¹⁶⁾</p> <p>CSA (XP) Class I, II, III Div. 1, Groups A, B, C, D, E, F, G²⁾⁵⁾⁷⁾</p> <p>CSA (NI) Class I, II, III, Div. 2, Groups A, B, C, D, E, F, G, CE²²⁾</p> <p>BR-Ex d IIC T6 ... T2⁵⁾¹⁸⁾</p> <p>CSA (IS) Class I, II, III Div. 1, Groups A, B, C, D, E, F, G⁶⁾⁹⁾</p> <p>ATEX II ½D, 2D ExtD A20/21, A21 IP6 T...⁶⁾²³⁾</p> <p>GOST-R/EAC + ATEX II 1G, ½G, 2G Ex ia IIC T6 + WHG⁹⁾²⁴⁾</p> <p>GOST-R/EAC + ATEX II ½G, Ex d IIC T2 ... T6 + WHG⁵⁾⁷⁾¹⁶⁾²⁶⁾</p> <p>GOST-R/EAC + ATEX II ½G, Ex d IIC T2 ... T6 + Ship approval⁵⁾⁷⁾¹⁶⁾²⁶⁾</p> <p>GOST-R/EAC + ATEX II 1G, ½G, 2G Ex ia IIC T6 + II ½D, 2D ExtD¹⁸⁾²⁴⁾</p> <p>GOST-R/EAC + ATEX II ½D, 2D ExtD A20/21, A21 IP6 T...¹⁸⁾²⁴⁾</p>	A B W C D E F G H K L N P Q R S T U V X Z Z Z Z Z	
<p>NOTE:</p> <p>When selecting a Process connection option, process connection coating must match the extension coating and the material and surface roughness type.</p>		
<p>Process connection</p> <p>Thread G¾" A, PN 64/316L</p> <p>Thread G¾" A, PN 64/316L Ra < 0.8 µm</p> <p>Thread ¾" NPT, PN 64/316L</p> <p>Thread ¾" NPT, PN 64/316L Ra < 0.8 µm</p> <p>Thread ¾" NPT, PN 64/Alloy 400 (2.4360)</p> <p>Thread G¾" A, PN 64/Alloy C22 (2.4602)</p> <p>Thread ¾" NPT, PN 64/Alloy C22 (2.4602)</p> <p>Thread G1" A, PN 64/316L</p> <p>Thread G1" A, PN 64/316L ECTFE coated MB1982⁴⁾</p> <p>Thread G1" A, PN 64/316L PFA coated⁴⁾</p> <p>Thread G1" A, PN 64/Alloy 400 (2.4360)</p> <p>Thread G1" A, PN 64/316L Ra < 0.8 µm</p>	A 0 0 A 0 1 A 0 2 A 0 3 A 0 4 A 0 5 A 0 6 A 0 7 A 0 8 A 1 0 A 1 1 A 1 3	
<p>SITRANS LVL200 Vibrating point level switch, rigid extension design</p> <p>Detects level and material in liquids and slurries. Top mount, with extension options to 6 m (19.69 ft). Ideal for hazardous applications.</p> <p>Thread 1" NPT, PN 64/316L</p> <p>Thread 1" NPT, PN 64/316L ECTFE coated MB1982⁴⁾</p> <p>Thread 1" NPT, PN 64/316L PFA coated⁴⁾</p> <p>Thread 1" NPT, PN 64/Alloy 400 (2.4360)</p> <p>Thread 1" NPT, PN 64/316L Ra < 0.8 µm</p> <p>Thread G1" A, PN 64/Alloy C22 (2.4602)</p> <p>Thread G1½" A, PN 64/316L</p> <p>Thread G1½" A, PN 64/316L Ra < 0.8 µm</p> <p>Thread G1½" A, PN 64/Alloy C22 (2.4602)</p> <p>Thread 1" NPT, PN 64/Alloy C22 (2.4602)</p> <p>Thread 1½" NPT, PN 64/316L</p> <p>Thread 1½" NPT, PN 64/316L Ra < 0.8 µm</p> <p>Thread 1½" NPT, PN 64/Alloy C22 (2.4602)</p> <p>Thread G2" A, PN 64/316L</p> <p>Thread M27 x 1.5 PN 64/316L</p> <p>Cyl. socket/316Ti/1.4581 ECTFE coated ZB2984⁴⁾</p> <p>Conus DN 25 PN 40/316L Ra < 0.3 µm</p> <p>Conus DN 25 PN 40/316L Ra < 0.8 µm</p> <p>Conus DN 25 PN 40/ECTFE (ZB3033)⁴⁾</p> <p>Conus M52 PN 40/316L</p> <p>Conus M52 PN 40/316L Ra < 0.3 µm</p> <p>Conus M52 PN 40/316L Ra < 0.8 µm</p> <p>Tri-Clamp 1" PN 16/316L Ra < 0.3 µm</p> <p>Tri-Clamp 1" PN 16/Alloy C22 (2.4602)</p> <p>Tri-Clamp 1" PN 16/316L Ra < 0.8 µm</p> <p>Tri-Clamp 1½" PN 16/316L Ra < 0.3 µm</p> <p>Tri-Clamp 1½" PN 16/Alloy C22 (2.4602)</p> <p>Tri-Clamp 1½" PN 16/316L Ra < 0.8 µm</p> <p>Tri-Clamp 2" PN 16/316L Ra < 0.3 µm</p> <p>Tri-Clamp 2" PN 16/Alloy C22 (2.4602)</p> <p>Tri-Clamp 2" PN 16/316L Ra < 0.8 µm</p> <p>Tri-Clamp 2½" PN 10/316L Ra < 0.3 µm</p> <p>Tri-Clamp 2½" PN 10/316L Ra < 0.8 µm</p> <p>Tri-Clamp 3" PN 10/316L Ra < 0.3 µm</p> <p>Clamp 3" PN16 (ø91 mm) DIN32676, ISO2852/ 316L (Ra < 0.8 µm)</p> <p>Bolting DN 32 PN 40 DIN 11851/316L Ra < 0.3 µm</p> <p>Bolting DN 32 PN 40 DIN 11851/316L Ra < 0.8 µm</p> <p>Bolting DN 25 PN 40 DIN 11851/316L Ra < 0.3 µm</p> <p>Bolting DN 25 PN 40 DIN 11851/316L Ra < 0.8 µm</p> <p>Bolting DN 40 PN 40 DIN 11851/316L Ra < 0.3 µm</p> <p>Bolting DN 40 PN 40 DIN 11851/316L Ra < 0.8 µm</p> <p>Bolting DN 40 PN 40 DIN 11864-1 A/316L Ra < 0.8 µm ZB3052</p> <p>Bolting DN 50 PN 25 DIN 11851/316L Ra < 0.3 µm</p> <p>Bolting DN 50 PN 25 DIN 11851/316L Ra < 0.8 µm</p> <p>Bolting DN 50 PN 25 DIN 11864- 1 A/316L Ra < 0.8 µm ZB3052</p> <p>Hygienic w.compr.nut F40 PN 25/316L</p> <p>Hygienic w.compr.nut F40 PN 25/316L Ra < 0.3 µm</p> <p>Hygienic w.compr.nut F40 PN 25/316L Ra < 0.8 µm</p> <p>Varivent N50-40/316L Ra < 0.3 µm</p> <p>Varivent N50-40/316L Ra < 0.8 µm</p> <p>Varivent N125/100/316L Ra < 0.8 µm</p> <p>DRD flange PN 40/316L ZB3007</p> <p>SMS DN 38/316L Ra < 0.8 µm⁴⁾</p> <p>SMS DN 51 PN 6/316L Ra < 0.8 µm⁴⁾</p> <p>Swagelok VCR screwing ZG2579 PN 64/316L</p>	A 1 4 A 1 5 A 1 6 A 1 7 A 1 8 A 2 0 A 2 1 A 2 2 A 2 3 A 2 4 A 2 5 A 2 6 A 2 7 A 2 8 A 3 0 A 3 1 A 3 2 A 3 3 A 3 4 A 3 5 A 3 6 A 3 7 A 3 8 A 4 0 A 4 1 A 4 2 A 4 3 A 4 4 A 4 5 A 4 6 A 4 7 A 4 8 A 5 0 A 5 1 A 5 2 A 5 3 A 5 4 A 5 5 A 5 6 A 5 7 A 5 8 A 6 0 A 6 1 A 6 2 A 6 3 A 6 4 A 6 5 A 6 6 A 6 7 A 6 8 A 7 0 A 7 1 A 7 2 A 7 3 A 7 4	



Level measurement

Point level measurement

Vibrating switches

SITRANS LVL200

Selection and ordering data

Article No.

Article No.

SITRANS LVL200 Vibrating point level switch, rigid extension design

Detects level and material in liquids and slurries. Top mount, with extension options to 6 m (19.69 ft). Ideal for hazardous applications.

	7ML5747-
Neumo biocontrol size 25 PN 16/316L Ra < 0.8 µm	A 7 5
Neumo biocontrol size 50 PN 16/316L Ra < 0.8 µm	A 7 6
SÜDMO DN 50 PN 10/316L Ra < 0.8 µm	A 8 0
Small flange DN 25 PN 1.5 DIN 28403/316L pol. Ra < 0.8 µm	A 8 1
Small flange DN 40 PN 1.5 DIN 28403/316L pol. Ra < 0.8 µm	A 8 2
Ingold connection PN 16/316L Ra < 0.8 µm	A 8 3
Collar clamp connection DN 33,7 PN 40 Form A, DIN 11864-3/1.4435 (BN2, Ra < 0.8 µm)	A 8 4
Collar flange DN 50 PN 16 Form A, DIN 11864-2/316L (Ra < 0.8 µm)	A 8 5
Flange DN 25 PN 6 Form C, DIN 2501/316L	A 8 6
Flange DN 25 PN 6 Form C, DIN 2501/PFA ⁴⁾	A 8 7
Flange DN 25 PN 40 Form C, DIN 2501/316L	A 8 8
Flange DN 25 PN 40 Form C, DIN 2501/Alloy C22 (2.4602) plated	B 0 0
Flange DN 25 PN 40 Form C, DIN 2501/ECTFE ⁴⁾	B 0 1
Flange DN 25 PN 40 Form C, DIN 2501/PFA ⁴⁾	B 0 2
Flange DN 25 PN 40 Form D, DIN 2501/316L	B 0 3
Flange DN 25 PN 40 Form F, DIN 2501/316L	B 0 4
Flange DN 25 PN 40 Form N, DIN 2501/316L	B 0 5
Flange DN 25 PN 40 Form N, DIN 2501/Alloy 400 (2.4360) solid	B 0 7
Flange DN 25 PN 40 V13, DIN 2501/316L	B 0 8
Flange DN 32 PN 40 Form C, DIN 2501/316L	B 1 0
Flange DN 32 PN 40 Form C, DIN 2501/ECTFE ⁴⁾	B 1 1
Flange DN 40 PN 6 Form C, DIN 2501/316L	B 1 2
Flange DN 40 PN 6 Form C, DIN 2501/ECTFE ⁴⁾	B 1 3
Flange DN 40 PN 40 Form C, DIN 2501/316L	B 1 4
Flange DN 40 PN 40 Form C, DIN 2501/Alloy C22 (2.4602) plated	B 1 5
Flange DN 40 PN 40 Form C, DIN 2501/ECTFE ⁴⁾	B 1 6
Flange DN 40 PN 40 Form C, DIN 2501/PFA ⁴⁾	B 1 7
Flange DN 40 PN 40 Form C, DIN 2501/Enamelled ³⁾	B 1 8
Flange DN 40 PN 40 Form F, DIN 2501/316L	B 2 0
Flange DN 40 PN 40 Form N, DIN 2501/316L	B 2 1
Flange DN 40 PN 40 Form E, DIN 2501/316L	B 2 2
Flange DN 40 PN 40 V13, DIN 2501/316L	B 2 3
Flange DN 50 PN 40 Form C, DIN 2501/316L	B 2 4
Flange DN 50 PN 40 Form C, DIN 2501/Alloy C22 (2.4602) plated	B 2 5
Flange DN 50 PN 40 Form C, DIN 2501/ECTFE ⁴⁾	B 2 6
Flange DN 50 PN 40 Form C, DIN 2501/ECTFE (ZB3108) ⁴⁾	B 2 7
Flange DN 50 PN 40 Form C, DIN 2501/PFA ⁴⁾	B 2 8
Flange DN 50 PN 40 Form D, DIN 2501/316L	B 3 0
Flange DN 50 PN 40 Form D, DIN 2501/Alloy C22 (2.4602)	B 3 1
Flange DN 50 PN 40 Form F, DIN 2501/316L	B 3 2
Flange DN 50 PN 40 Form N, DIN 2501/316L	B 3 3
Flange DN 50 PN 40 Form N, DIN 2501/Alloy C22 (2.4602) solid	B 3 4
Flange DN 50 PN 40 Form E, DIN 2501/316L	B 3 5
Flange DN 50 PN 40 V13, DIN 2501/316L	B 3 6
Flange DN 50 PN 40 R13, DIN 2501/316L	B 3 7
Flange DN 50 PN 64 Form F, DIN 2501/316L	B 3 8
Flange DN 50 PN 64 Form C, DIN 2501/316L	B 4 1
Flange DN 50 PN 64 Form L, DIN 2501/316L	B 4 2

SITRANS LVL200 Vibrating point level switch, rigid extension design

Detects level and material in liquids and slurries. Top mount, with extension options to 6 m (19.69 ft). Ideal for hazardous applications.

	7ML5747-
Flange DN 50 PN 100 Form E, DIN 2501/316L	B 4 3
Flange DN 50 PN 100 Form L, DIN 2501/316L	B 4 4
Flange DN 65 PN 40 Form C, DIN 2501/316L	B 4 5
Flange DN 65 PN 40 Form C, DIN 2501/ECTFE ⁴⁾	B 4 7
Flange DN 65 PN 40 Form C, DIN 2501/PFA ⁴⁾	B 4 8
Flange DN 65 PN 40 Form F, DIN 2501/316L	B 5 0
Flange DN 65 PN 64 Form E, DIN 2501/316L	B 5 1
Flange DN 80 PN 40 Form C, DIN 2501/316L	B 5 2
Flange DN 80 PN 40 Form C, DIN 2501/Alloy C22 (2.4602) plated	B 5 3
Flange DN 80 PN 40 Form C, DIN 2501/ECTFE ⁴⁾	B 5 4
Flange DN 80 PN 40 Form C, DIN 2501/PFA ⁴⁾	B 5 5
Flange DN 80 PN 40 Form F, DIN 2501/316L	B 5 6
Flange DN 80 PN 40 Form N, DIN 2501/316L	B 5 7
Flange DN 100 PN 16 Form C, DIN 2501/316L	B 6 0
Flange DN 100 PN 16 Form C, DIN 2501/Alloy C22 (2.4602) plated	B 6 1
Flange DN 100 PN 16 Form C, DIN 2501/ECTFE ⁴⁾	B 6 2
Flange DN 100 PN 16 Form C, DIN 2501/PFA ⁴⁾	B 6 3
Flange DN 100 PN 16 Form D, DIN 2501/316L	B 6 4
Flange DN 100 PN 16 Form F, DIN 2501/316L	B 6 5
Flange DN 100 PN 16 Form N, DIN 2501/316L	B 6 6
Flange DN 100 PN 40 Form C, DIN 2501/316L	B 6 7
Flange DN 100 PN 40 Form C, DIN 2501/ECTFE ⁴⁾	B 6 8
Flange DN 100 PN 40 Form C, DIN 2501/PFA ⁴⁾	B 7 0
Flange DN 100 PN 40 Form C, DIN 2501/Enamelled ³⁾	B 7 1
Flange DN 100 PN 40 Form F, DIN 2501/316L	B 7 2
Flange DN 100 PN 40 Form N, DIN 2501/316L	B 7 3
Flange DN 100 PN 40 V13, DIN 2501/316L	B 7 4
Flange DN 100 PN 64 Form E, DIN 2501/316L	B 7 5
Flange DN 100 PN 100 Form E, DIN 2501/316L	B 7 6
Flange DN 100 PN 100 Form L, DIN 2501/316L	B 7 7
Flange DN 125 PN 16 Form F, DIN 2501/316L	B 7 8
Flange DN 125 PN 40 Form C, DIN 2501/316L	B 8 0
Flange DN 125 PN 40 Form N, DIN 2512/316L	B 8 1
Flange DN 150 PN 16 Form C, DIN 2501/316L	B 8 2
Flange DN 150 PN 16 Form C, DIN 2501/Alloy C22 (2.4602) plated	B 8 3
Flange DN 150 PN 16 Form C, DIN 2501/ECTFE ⁴⁾	B 8 4
Flange DN 150 PN 16 Form C, DIN 2501/PFA ⁴⁾	B 8 5
Flange DN 150 PN 16 Form D, DIN 2501/316L	B 8 6
Flange DN 150 PN 40 Form C, DIN 2501/316L	B 8 7
Flange DN 150 PN 40 Form C, DIN 2501/Alloy C22 (2.4602) plated	B 8 8

Selection and ordering data	Article No.	Article No.
SITRANS LVL200 Vibrating point level switch, rigid extension design	7ML5747-	7ML5747-
Detects level and material in liquids and slurries. Top mount, with extension options to 6 m (19.69 ft). Ideal for hazardous applications.		Detects level and material in liquids and slurries. Top mount, with extension options to 6 m (19.69 ft). Ideal for hazardous applications.
Flange DN 150 PN 40 Form F, DIN 2501/316L	C 0 0	Flange DN 150 PN 40 Form B1, EN 1092-1/316L C 4 4
Flange DN 150 PN 40 Form N, DIN 2512/316L	C 0 1	Flange DN 150 PN 40 Form B1, EN 1092-1/ECTFE ⁴⁾ C 4 5
Flange DN 200 PN 10 Form C, DIN 2501/ECTFE ⁴⁾	C 0 2	Flange DN 150 PN 40 Form B2, EN 1092-1/316L C 4 6
Flange DN 200 PN 16 Form C, DIN 2501/316L	C 0 3	Flange 1" 150 lb ASME B16.5/316L C 4 7
Flange DN 25 PN 40 Form B1, EN 1092-1/316L	C 0 4	Flange 1" 150 lb RF, ASME B16.5/Alloy C22 (2.4602) plated C 4 8
Flange DN 25 PN 40 Form B1, EN 1092-1/Alloy C22 (2.4602) plated	C 0 5	Flange 1" 150 lb RF, ASME B16.5/Alloy 400 (2.4360) ZB2977 C 5 0
Flange DN 25 PN 40 Form B1, EN/316L/PFA ⁴⁾	C 0 6	Flange 1" 150 lb RF, ASME B16.5/ECTFE ⁴⁾ C 5 1
Flange DN 25 PN 40 Form B1, EN 1092-1/Enamelled ³⁾	C 0 7	Flange 1" 150 lb RF, ASME B16.5/PFA ⁴⁾ C 5 2
Flange DN 25 PN 40 Form B2, EN 1092-1/316L	C 0 8	Flange 1" 150 lb RF, ASME B16.5/Enamelled ³⁾ C 5 3
Flange DN 25 PN 40 Form F, EN 1092-1/316L	C 1 0	Flange 1" 300 lb RF, ASME B16.5/316L C 5 4
Flange DN 25 PN 63 Form B1, EN 1092-1/316L	C 1 1	Flange 1" 300 lb RF, ASME B16.5/ECTFE ⁴⁾ C 5 5
Flange DN 25 PN 100 Form B2, EN 1092-1/316L	C 1 2	Flange 1" 600 lb RF, ASME B16.5/316L C 5 6
Flange DN 40 PN 40 Form B1, EN/316L	C 1 3	Flange 1½" 150 lb RF, ASME B16.5/316L C 5 7
Flange DN 40 PN 40 Form B1, EN 1092-1/PFA ⁴⁾	C 1 4	Flange 1½" 150 lb RF, ASME B16.5/Alloy C22 (2.4602) plated C 5 8
Flange DN 40 PN 40 Form B2, EN/316L	C 1 5	Flange 1½" 150 lb RF, ASME B16.5/ECTFE ⁴⁾ C 6 0
Flange DN 50 PN 40 Form B1, EN/316L	C 1 6	Flange 1½" 150 lb RF, ASME B16.5/PFA ⁴⁾ C 6 1
Flange DN 50 PN 40 Form B1, EN 1092-1/Alloy C22 (2.4602) plated	C 1 7	Flange 1½" 150 lb RF, ASME B16.5/Enamelled ³⁾ C 6 2
Flange DN 50 PN 40 Form B1, EN 1092-1/Alloy 400 (2.4360) ZB2977	C 1 8	Flange 1½" 150 lb FF, ASME B16.5/ECTFE ⁴⁾ C 6 3
Flange DN 50 PN 40 Form B1, EN 1092-1/ECTFE ⁴⁾	C 2 0	Flange 1½" 300 lb RF, ASME B16.5/316L C 6 4
Flange DN 50 PN 40 Form B1, EN/316L/PFA ⁴⁾	C 2 1	Flange 1½" 300 lb RF, ASME B16.5/Alloy 400 (2.4360) ZB2977 C 6 5
Flange DN 50 PN 40 Form B1, EN 1092-1/Enamelled ³⁾	C 2 2	Flange 1½" 300 lb RF, ASME B16.5/ECTFE ⁴⁾ C 6 6
Flange DN 50 PN 40 Form C, EN 1092-1/316L	C 2 3	Flange 1½" 600 lb RF, ASME B16.5/316L C 6 7
Flange DN 50 PN 40 Form D, EN/316L	C 2 4	Flange 2" 150 lb RF, ASME B16.5/316L C 6 8
Flange DN 50 PN 40 Form B2, EN 1092-1/316L	C 2 6	Flange 2" 150 lb RF, ASME B16.5/Alloy C22 (2.4602) plated C 7 0
Flange DN 50 PN 40 Form E, EN 1092-1/316L	C 2 7	Flange 2" 150 lb RF, ASME B16.5/PFA ⁴⁾ C 7 1
Flange DN 80 PN 40 Form B1, EN 1092-1/316L	C 2 8	Flange 2" 150 lb RF, ASME B16.5/Enamelled ³⁾ C 7 2
Flange DN 80 PN 40 Form B1, EN 1092-1/Alloy C22 (2.4602) plated	C 3 0	Flange 2" 150 lb FF, ASME B16.5/316L C 7 5
Flange DN 80 PN 40 Form B1, EN 1092-1/ECTFE ⁴⁾	C 3 1	Flange 2" 150 lb FF, ASME B16.5/ECTFE ⁴⁾ C 7 6
Flange DN 80 PN 40 Form B1, EN 1092-1/Enamelled ³⁾	C 3 2	Flange 2" 150 lb SG (small groove), ASME B16.5/316L C 7 7
Flange DN 80 PN 40 Form B2, EN 1092-1/316L	C 3 3	Flange 2" 300 lb RF, ASME B16.5/316L C 7 8
Flange DN 100 PN 16 Form B1, EN 1092-1/316L	C 3 4	Flange 2" 300 lb RF, ASME B16.5/Alloy C22 (2.4602) plated C 8 0
Flange DN 100 PN 16 Form B1, EN 1092-1/Alloy C22 (2.4602) plated	C 3 5	Flange 2" 300 lb RF, ASME B16.5/ECTFE ⁴⁾ C 8 2
Flange DN 100 PN 16 Form B1, EN 1092-1/Enamelled ³⁾	C 3 6	Flange 2" 300 lb RF, ASME B16.5/PFA ⁴⁾ C 8 3
Flange DN 100 PN 40 Form B1, EN 1092-1/316L	C 3 7	Flange 2" 300 lb RJF, ASME B16.5/316L C 8 5
Flange DN 100 PN 40 Form B1, EN 1092-1/Enamelled ³⁾	C 3 8	Flange 2" 300 lb ST, ASME B16.5/316L C 8 6
Flange DN 100 PN 40 Form C, EN 1092-1/316L	C 4 0	Flange 2" 300 lb LG (large groove), ASME B16.5/316L C 8 7
Flange DN 100 PN 63 Form B2, EN 1092-1/316L	C 4 1	Flange 2" 300 lb LT, ASME B16.5/316L C 8 8
Flange DN 150 PN 16 Form B1, EN 1092-1/316L	C 4 2	Flange 2" 600 lb RF, ASME B16.5/316L D 0 0
Flange DN 150 PN 16 Form B1, EN 1092-1/PFA ⁴⁾	C 4 3	Flange 2" 600 lb RF, ASME B16.5/Alloy 400 (2.4360) ZB2977 D 0 1
		Flange 2" 600 lb RF, ASME B16.5/ECTFE ⁴⁾ D 0 2
		Flange 2" 600 lb RJF, ASME B16.5/316L D 0 3
		Flange 2" 600 lb LG, ASME B16.5/316L D 0 4
		Flange 2" 900 lb RJF, ASME B16.5/316L D 0 5
		Flange 2½" 150 lb RF, ASME B16.5/316L D 0 6
		Flange 2½" 300 lb RF, ASME B16.5/316L D 0 7
		Flange 3" 150 lb RF, ASME B16.5/316L D 0 8
		Flange 3" 150 lb RF, ASME B16.5/Alloy C22 (2.4602) plated D 1 0
		Flange 3" 150 lb RF, ASME B16.5/Alloy 400 (2.4360) ZB2977 D 1 1
		Flange 3" 150 lb RF, ASME B16.5/ECTFE ⁴⁾ D 1 2
		Flange 3" 150 lb RF, ASME B16.5/PFA ⁴⁾ D 1 3



Level measurement

Point level measurement
Vibrating switches

SITRANS LVL200

Selection and ordering data

Article No.

Article No.

SITRANS LVL200 Vibrating point level switch, rigid extension design

7ML5747-

Detects level and material in liquids and slurries. Top mount, with extension options to 6 m (19.69 ft). Ideal for hazardous applications.

Flange 3" 150 lb RF, ASME B16.5/Enamelled ³⁾	D 1 4
Flange 3" 150 lb FF, ASME B16.5/316L	D 1 5
Flange 3" 150 lb FF, ASME B16.5/ECTFE ⁴⁾	D 1 6
Flange 3" 150 lb FF, ASME B16.5/PFA ⁴⁾	D 1 7
Flange 3" 300 lb RF, ASME B16.5/316L	D 1 8
Flange 3" 300 lb RF, ASME B16.5/Alloy C22 (2.4602) plated	D 2 0
Flange 3" 300 lb RF, ASME B16.5/ECTFE ⁴⁾	D 2 1
Flange 3" 300 lb RF, ASME B16.5/PFA ⁴⁾	D 2 2
Flange 3" 300 lb RF, ASME B16.5/Enamelled ³⁾	D 2 3
Flange 3" 600 lb RF, ASME B16.5/316L	D 2 4
Flange 3½" 150 lb RF, ASME B16.5/316L	D 2 5
Flange 3½" 150 lb RF, ASME B16.5/ECTFE ⁴⁾	D 2 6
Flange 4" 150 lb RF, ASME B16.5/316L	D 2 7
Flange 4" 150 lb RF, ASME B16.5/Alloy C22 (2.4602) plated	D 2 8
Flange 4" 150 lb RF, ASME B16.5/ECTFE ⁴⁾	D 3 0
Flange 4" 150 lb RF, ASME B16.5/PFA ⁴⁾	D 3 1
Flange 4" 150 lb RF, ASME B16.5/Enamelled ³⁾	D 3 2
Flange 4" 150 lb LT, ASME B16.5/316L	D 3 3
Flange 4" 300 lb RF, ASME B16.5/316L	D 3 4
Flange 4" 300 lb RF, ASME B16.5/Alloy C22 (2.4602) plated	D 3 5
Flange 4" 300 lb RF, ASME B16.5/ECTFE ⁴⁾	D 3 6
Flange 4" 300 lb RJF, ASME B16.5/316L	D 3 7
Flange 4" 300 lb LG, ASME B16.5/316L	D 3 8
Flange 4" 300 lb LT, ASME B16.5/316L	D 4 0
Flange 4" 600 lb RF, ASME B16.5/316L	D 4 1
Flange 4" 600 lb RJF, ASME B16.5/316L	D 4 2
Flange 5" 150 lb RF, ASME B16.5/316L	D 4 3
Flange 6" 150 lb RF, ASME B16.5/316L	D 4 4
Flange 6" 150 lb RF, ASME B16.5/Alloy C22 (2.4602) plated	D 4 5
Flange 6" 150 lb RF, ASME B16.5/ECTFE ⁴⁾	D 4 6
Flange 6" 150 lb RF, ASME B16.5/PFA ⁴⁾	D 4 7
Flange 6" 150 lb RJF, ASME B16.5/316L	D 4 8
Flange 6" 300 lb RF, ASME B16.5/316L	D 5 0
Flange 8" 150 lb RF, ASME B16.5/316L	D 5 1
Flange 8" 150 lb RF, ASME B16.5/ECTFE ⁴⁾	D 5 2
Flange 1" BS.10 Table E/316L	D 5 3
Flange 1" BS.10 Table E/PFA ⁴⁾	D 5 4
Flange 1½" BS.10 Table E/316L	D 5 5
Flange 3½" BS.10 Table E/316L	D 5 6
Flange 4" BS.10 Table E/ECTFE ⁴⁾	D 5 7
Flange DN 40 10K, JIS/316L	D 5 8
Flange DN 50 10K, JIS/316L	D 6 0
Flange DN 80 10K, JIS/316L	D 6 1
Flange DN 100 10K, JIS/316L	D 6 2
Thread R1 PN 64, EN10226-1/316L ¹¹⁾	D 6 5
Flange 2" 900 lb RF, ASME B16.5/316L	D 7 0
Flange 4" 150 lb RF, ASME B16.5/Alloy C22 (2.4602) solid	D 7 1
Flange NPS 2" Class 1500 RJF, ASME B16.5/316/316L ²⁶⁾	D 7 2

Adapter/Process temperature

Without adapter/-50 ... +150 °C	1
With adapter/-50 ... +200 °C ¹³⁾	2
With adapter/-50 ... +250 °C	3
With gas-tight leadthrough/-50 ... +150 °C	4
With gas-tight leadthrough/-50 ... +250 °C	5

Housing/Cable entry

Aluminum IP66/IP67/M20 x 1.5	A
Aluminum IP66/IP67/½" NPT	B
316L stainless steel (electropolished) IP66/IP67/M20 x 1.5	C
316L stainless steel (electropolished) IP66/IP67/½" NPT	D

SITRANS LVL200 Vibrating point level switch, rigid extension design

7ML5747-

Detects level and material in liquids and slurries. Top mount, with extension options to 6 m (19.69 ft). Ideal for hazardous applications.

Plastic single chamber IP66/IP67/M20 x 1.5	E
Plastic single chamber IP66/IP67/½" NPT	F
Stainless steel chamber (precision casting) IP66/IP67/M20 x 1.5	G
Stainless steel chamber (precision casting) IP66/IP67/½" NPT	H
Aluminum IP66/IP67/M20 x 1.5 Special HARTING plug HAN 7D (bent) according to Tier One (ZB7555)	V

NOTE:

When selecting a Rigid Extension option, extension coating must match the process connection coating and the material and surface roughness type.

Rigid Extension 316L

80 ... 500 mm	A 0
501 ... 1 000 mm	A 1
1 001 ... 1 500 mm	A 2
1 501 ... 2 000 mm	A 3
2 001 ... 2 500 mm	A 4
2 501 ... 3 000 mm	A 5
3 001 ... 3 500 mm	A 6
3 501 ... 4 000 mm	A 7

Rigid Extension ECTFE coated

80 ... 500 mm	B 0
501 ... 1 000 mm	B 1
1 001 ... 1 500 mm	B 2
1 501 ... 2 000 mm	B 3
2 001 ... 2 500 mm	B 4
2 501 ... 3 000 mm	B 5

Rigid Extension PFA coated

80 ... 500 mm	C 0
501 ... 1 000 mm	C 1
1 001 ... 1 500 mm	C 2
1 501 ... 2 000 mm	C 3
2 001 ... 2 500 mm	C 4
2 501 ... 3 000 mm	C 5
3 001 ... 3 500 mm	C 6
3 501 ... 4 000 mm	C 7

Rigid Extension 316L Ra ≤ 0.8 µm

80 ... 500 mm	D 0
501 ... 1 000 mm	D 1
1 001 ... 1 500 mm	D 2
1 501 ... 2 000 mm	D 3
2 001 ... 2 500 mm	D 4
2 501 ... 3 000 mm	D 5
3 001 ... 3 500 mm	D 6
3 501 ... 4 000 mm	D 7

Rigid Extension 316L Ra ≤ 0.3 µm

80 ... 500 mm	E 0
501 ... 1 000 mm	E 1
1 001 ... 1 500 mm	E 2
1 501 ... 2 000 mm	E 3
2 001 ... 2 500 mm	E 4
2 501 ... 3 000 mm	E 5
3 001 ... 3 500 mm	E 6
3 501 ... 4 000 mm	E 7

Rigid Extension Enamelled version

80 ... 250 mm	F 0
251 ... 500 mm	F 1
501 ... 750 mm	F 2
751 ... 1 000 mm	F 3
1 001 ... 1 250 mm	F 4
1 251 ... 1 500 mm	F 5

Selection and ordering data	Article No.	Article No.
SITRANS LVL200 Vibrating point level switch, rigid extension design Detects level and material in liquids and slurries. Top mount, with extension options to 6 m (19.69 ft). Ideal for hazardous applications.	7ML5747-	
Rigid Extension Alloy C22 (2.4602) 80 ... 500 mm 501 ... 1 000 mm 1 001 ... 1 500 mm 1 501 ... 2 000 mm 2 001 ... 2 500 mm 2 501 ... 3 000 mm 3 001 ... 3 500 mm 3 501 ... 4 000 mm	G 0 G 1 G 2 G 3 G 4 G 5 G 6 G 7	
Rigid Extension Alloy 400 (2.4360) 80 ... 500 mm 501 ... 1 000 mm 1 001 ... 1 500 mm 1 501 ... 2 000 mm 2 001 ... 2 500 mm 2 501 ... 3 000 mm	H 0 H 1 H 2 H 3 H 4 H 5	
Further designs Please add *-Z* to Article No. and specify Order code(s).	Order code	
Switching status indication with colors red-green ¹²⁾	A21	
Cleaning including Certificate (oil, grease, and silicone free)	W01	
Enter the total insertion length in plain text description, max. 4 000 mm (157.48 inch)	Y01	
Identification label (measurement loop) stainless steel: max. 40 characters, add in plain text. To add more than one line, use a coma ", " for line break.	Y17	
Identification label (measurement loop) foil: max. 40 characters add in plain text. To add more than one line, use a coma ", " for line break.	Y18	
NACE0175 to 3.1 Material Certificate for material (EN 10204 NACE MR 0175) ⁸⁾ Note: not available with Process connection and Rigid extension coatings PFA, ECTFE, and Enamel. NACE not available with Hygienic process connections.	D07	
Material Inspection certificate 3.1 of EN 10204 2.2-Factory certificate for material (EN 10204) ⁸⁾	C05	
Functional Safety (SIL 2). Device suitable for use in accordance with IEC 61508 and IEC 61511 ⁸⁾	C15	
Dye penetration test, results confirmed via a 3.1 certificate/instrument (EN 10204) ⁸⁾	C13	
X-ray test + 3.1 certificate/instrument ⁸⁾	C14	
Positive material identification test + 3.1 certificate/instrument ⁸⁾	C16	
Roughness test + 3.1 certificate/instrument ⁸⁾	C18	
3.1-Inspection Certificate for instrument with test data (EN 10204)	C25	
Quality and test plan	C26	
Inspection certificate 3.1 (EN 10204) - device and pressure test ⁸⁾	C31	
Helium leak test + 3.1 certificate/instrument ⁸⁾	C32	
Ferrite measuring accuracy to DIN 32514-1 + 3.1 certificate/instrument ⁸⁾	C60	
Pressure test according to Norsok + 3.1 certificate/instrument ⁸⁾	C61	
Factory declaration 2.1 (EN 10204) - certificate suitable for tropical regions with all attachment parts of metal	C65	
Operating Instructions All literature is available to download for free, in a range of languages, at http://www.siemens.com/processinstrumentation/documentation		
Spare Parts and Accessories Electronics module SITRANS LVL200 Relay Electronics module SITRANS LVL200 Contactless NAMUR spare electronics module SITRANS SCSC single channel signal conditioner and remote test SITRANS TCSC two channel signal conditioner and remote test Lock fitting, unpressurized, G1" A/316L Lock fitting, unpressurized, 1" NPT/316L Lock fitting, unpressurized, G1 ... 1/2" A/316L Lock fitting, unpressurized, 1 ... 1/2" NPT/316L Lock fitting, -1 ... 16 bar, G1" A/316L Lock fitting, -1 ... 16 bar, 1" NPT/316L Lock fitting, -1 ... 16 bar, G1 1/2" A/316L Lock fitting, -1 ... 16 bar, 1 1/2" NPT/316L Lock fitting, -1 ... 64 bar, G1" A/316L Lock fitting, -1 ... 64 bar, 1" NPT/316L Lock fitting, -1 ... 64 bar, G1 1/2" A/316L Lock fitting, -1 ... 64 bar, 1 1/2" NPT/316L	7ML1830-1NC 7ML1930-6AA A5E35817107 7ML5760-.....-..... 7ML5761-.....-..... 7ML1930-1DQ 7ML1930-1DR 7ML1930-1DS 7ML1930-1DT 7ML1930-1DU 7ML1930-1DV 7ML1930-1DW 7ML1930-1DX 7ML1930-1EA 7ML1930-1EB 7ML1930-1EC 7ML1930-1ED	
¹⁾ Available only with Adapter/Process temperature options 1, 3, 4, and 5. ²⁾ Available only with Housing/Cable entry option B. ³⁾ Available only with Adapter/Process temperature options 1, 2, and 4. ⁴⁾ Not available with Adapter/Process temperature options 2, 3, and 5. ⁵⁾ Not available with Adapter/Process temperature options 2, 4, and 5. ⁶⁾ Available only with Electronics options 4 and 6. ⁷⁾ Available only with Rigid extension options less than 3 001 mm. ⁸⁾ Listed Certificates are not available with all configurations please contact factory for more information. ⁹⁾ Not available with Housing/Protection/Cable option V. ¹⁰⁾ Not available with PFA, ECTFE, and enamelled coating options. ¹¹⁾ Available only with some 316L extensions. ¹²⁾ Available only with Relay electronic options and non-hazardous Approval options. ¹³⁾ Available only with Enamelled Process connection/Material options. ¹⁴⁾ Not available with Approval options C, E, G, H, L, N, V, and W. ¹⁵⁾ Not available with Approval options C, E, G, H, N, and V. ¹⁶⁾ Only available with Aluminum Housing/Protection/Cable options and certain glands. ¹⁷⁾ Not available with Stainless Steel Electropolish Housing/Protection/Cable options and certain glands. ¹⁸⁾ Not available with Plastic or Stainless Steel Electropolish Housing/Protection/Cable options and certain glands. ¹⁹⁾ Not available with Housing/Protection/Cable options D and V. ²⁰⁾ Not available with Housing/Protection/Cable options A, E, G, and V. ²¹⁾ Not available with some Housing/Protection/Cable gland options. ²²⁾ Not available with Housing/Protection/Cable options A, C, and V. ²³⁾ Not available with Plastic Housing/Protection/Cable options. ²⁴⁾ Available only with Electronic option 4. ²⁵⁾ Not available with FM approval options. ²⁶⁾ Available only with Rigid extension options A0 ... A7.		

Level measurement

Point level measurement

Vibrating switches

SITRANS LVL200

Selection and ordering data

Article No.

Article No.

SITRANS LVL200 Vibrating point level switch, high temperature and pressure design

Detects level and material in liquids and slurries in extreme environments. Extension options to 3 m (9.84 ft).

➤ Click on the Article No. for the online configuration in the PIA Life Cycle Portal.

Version/Material

Compact version/Inconel 718 (2.4668)¹⁾²⁾ **1**
 With tube extension/316L and Inconel 718 (2.4668)¹⁾³⁾ **2**
 With tube extension/Alloy C22 (2.4602) and Inconel 718 (2.4668)⁴⁾ **3**

Approvals

Europe CE **A**
 Ship approval **B**
 Overfill protection WHG⁷⁾ **C**
 ATEX II ½G, 2G Ex d IIC T6⁶⁾⁹⁾ **D**
 ATEX II 1G, ½G, 2G Ex ia IIC T6⁵⁾⁹⁾ **F**
 ATEX II 1G, ½G, 2G Ex ia IIC T6 + ship approval⁵⁾⁹⁾¹⁰⁾ **G**
 ATEX II 1G, ½G, 2G Ex ia IIC T6 + Overfill protection (WHG)⁶⁾⁷⁾⁹⁾ **H**
 ATEX II ½G, 2G Ex d IIC T6 + Overfill protection (WHG)⁶⁾⁷⁾⁹⁾ **J**
 FM (NI) Class I, Div. 2, Groups A, B, C, D T6 ... T1⁹⁾¹¹⁾ **N**
 FM (NI) Class I, Div. 2, Groups A, B, C, D T6 ... T1 + Ship approval⁶⁾⁹⁾ **P**
 FM (IS) Class I, Div. 1, Groups A, B, C, D Zone 0, 0/1, 1, AEx ia IIC T6 ... T1 Ga, Ga/Gb, Gb⁵⁾⁹⁾¹²⁾ **Q**
 FM (XP) Class I, Div. 1, Groups A, B, C, D T6 ... T1, Zone 0/1, 1, AEx d IIC T6 ... T1 Ga/Gb, Gb⁶⁾⁹⁾ **R**
 FM (XP) Class I, Div. 1, Groups A, B, C, D T6 ... T1, Zone 0/1, 1, AEx d IIC T6 ... T1 Ga/Gb, Gb + Ship approval⁶⁾⁹⁾ **S**
 IEC Ex d IIC T6⁶⁾⁹⁾ **E**
 IEC Ex ia IIC T6 + Ship approval⁵⁾⁹⁾¹⁰⁾ **U**
 IEC Ex ia IIC T6⁵⁾⁹⁾ **T**
 cCSA_{US} (NI) Class I, Div. 2, Groups A, B, C, D, (DIP) Class II, III, Div. 1, Groups E, F, G⁶⁾⁹⁾ **V**
 cCSA_{US} (NI) Class I, Div. 2, Groups A, B, C, D, (DIP) Class II, III, Div. 1, Groups E, F, G + Ship approval⁶⁾⁹⁾ **W**
 cCSA_{US} (IS) Class I, II, III, Div. 1, Groups A, B, C, D, E, F, G⁵⁾⁹⁾¹²⁾ **X**
 cCSA_{US} (IS) Class I, II, III, Div. 1, Groups A, B, C, D, E, F, G + Ship approval⁵⁾⁹⁾¹³⁾ **Y**
 cCSA_{US} (XP) Class I, II, III, Div. 1, Groups A, B, C, D, E, F, G⁶⁾⁹⁾ **K**
 cCSA_{US} (XP) Class I, II, III, Div. 1, Groups A, B, C, D, E, F, G + Ship approval⁶⁾⁹⁾ **L**
 GOST-R/EAC Ga/Gb Ex ia IIC T6 ... T1 X, 0Ex ia IIC T6 ... T1 Ga, 1Ex ia IIC T6 ... T1 Gb X⁵⁾⁹⁾ **Z** **J 1 A**
 GOST-R/EAC 1Ex db IIC T6 ... T1 Gb, Ga/Gb Ex db IIC T6 ... T1⁶⁾⁹⁾ **Z** **J 1 B**

SITRANS LVL200 Vibrating point level switch, high temperature and pressure design

Detects level and material in liquids and slurries in extreme environments. Extension options to 3 m (9.84 ft).

Process connection

Thread G1 PN 100, DIN 3852-A/316L **A 0**
 Thread G1 PN 160, DIN 3852-A/Inconel 718 (2.4668) **A 1**
 Thread 1" NPT PN 100, ASME B1.20.1/316L **A 2**
 Thread 1" NPT PN 160, ASME B1.20.1/Inconel 718 (2.4668) **A 3**
 Flange DN 50 PN 40 Form C, DIN 2501/316/316 **A 4**
 Flange DN 50 PN 40 Form C, DIN 2501/316/316L, with Alloy C22 (2.4602) coating **A 5**
 Flange DN 50 PN 40 Form N, DIN 2501/316/316L **A 6**
 Flange DN 50 PN 40 Form V13, DIN 2501/316/316L **A 7**
 Flange DN 50 PN 40 Form V13, DIN 2501/Alloy C22 (2.4602) solid **A 8**
 Flange DN 50 PN 40 Form V13, DIN 2501/316/316L, with Alloy C22 (2.4602) coating **B 0**
 Flange DN 50 PN 64 Form E, DIN 2501/316/316L **B 1**
 Flange DN 50 PN 100 Form C, DIN 2501/316/316L **B 2**
 Flange DN 50 PN 100 Form F, DIN 2501/316/316L **B 3**
 Flange DN 50 PN 100 Form V13, DIN 2501/316/316L **B 4**
 Flange DN 50 PN 160 Form C, DIN 2501/316/316L **B 5**
 Flange DN 50 PN 160 Form F, DIN 2501/316/316L **B 6**
 Flange DN 65 PN 16 Form C, DIN 2501/316/316L **B 7**
 Flange DN 65 PN 40 Form C, DIN 2501/316/316L **B 8**
 Flange DN 65 PN 100 Form C, DIN 2501/316/316L **C 0**
 Flange DN 80 PN 40 Form C, DIN 2501/316/316L **C 1**
 Flange DN 80 PN 100 Form C, DIN 2501/316/316L **C 2**
 Flange DN 80 PN 160 Form F, DIN 2501/316/316L **C 3**
 Flange DN 80 PN 160 Form L, DIN 2501/316/316L **C 4**
 Flange DN 80 PN 250 Form L, DIN 2501/316/316L **C 5**
 Flange DN 80 PN 250 Form L, DIN 2501/Alloy C22 (2.4602) solid **C 6**
 Flange DN 100 PN 16 Form C, DIN 2501/316/316L **C 7**
 Flange DN 100 PN 40 Form C, DIN 2501/316/316L **C 8**
 Flange DN 100 PN 100 Form E, DIN 2501/316/316L **D 0**
 Flange DN 100 PN 160 Form L, DIN 2501/316/316L **D 1**
 Flange DN 125 PN 16 Form C, DIN 2501/316/316L **D 2**
 Flange DN 125 PN 40 Form C, DIN 2501/316/316L **D 3**
 Flange DN 150 PN 16 Form C, DIN 2501/316/316L **D 4**
 Flange DN 150 PN 16 Form C, DIN 2501/316/316L, with Alloy C22 (2.4602) coating **D 5**
 Flange DN 150 PN 40 Form C, DIN 2501/316/316L **D 6**
 Flange DN 150 PN 160 Form L, DIN 2501/316/316L **D 7**

4

Selection and ordering data	Article No.	Article No.
SITRANS LVL200 Vibrating point level switch, high temperature and pressure design Detects level and material in liquids and slurries in extreme environments. Extension options to 3 m (9.84 ft).	7ML5748-	7ML5748-
Flange DN 200 PN 16 Form C, DIN 2501/316/316L	D 8	F 0
Flange DN 200 PN 64 Form C, DIN 2501/316/316L	E 0	F 1
Flange DN 250 PN 16 Form C, DIN 2501/316/316L	E 1	F 2
Flange DN 250 PN 64 Form C, DIN 2501/316/316L	E 2	F 3
Flange DN 50 PN 40 Form B1, EN 1092-1/1.4435	E 3	F 4
Flange DN 50 PN 40 Form B1, EN 1092-1/316/316L	E 4	F 5
Flange DN 50 PN 40 Form B1, EN 1092-1/316/316L, with Alloy C22 (2.4602) coating	E 5	F 6
Flange DN 50 PN 40 Form B2, EN 1092-1/316/316L	E 6	F 7
Flange DN 50 PN 40 Form C, EN 1092-1/316/316L	E 7	F 8
Flange DN 50 PN 40 Form D, EN 1092-1/316/316L	E 8	G 0
		G 1
		G 2
		G 3
		G 4
		G 5
		G 6
		G 7
		G 8
		H 0
		H 1
		H 2
		H 3
		H 4
		H 5
		H 6
		H 7
		H 8
		K 0
		K 1
		K 2
		K 3
		K 4
		K 5
		K 6
		K 7

Level measurement

Point level measurement

Vibrating switches

SITRANS LVL200

Selection and ordering data

Article No.

Article No.

SITRANS LVL200 Vibrating point level switch, high temperature and pressure design

7ML5748-

Detects level and material in liquids and slurries in extreme environments. Extension options to 3 m (9.84 ft).

Flange 1½" 150 lb RJF, ASME B16.5/316/316L	K 8
Flange 1½" 300 lb RJF, ASME B16.5/316/316L	L 1
Flange 1½" 1 500 lb RJF, ASME B16.5/316/316L	L 2
Flange 2" 150 lb RF, ASME B16.5/316/316L	L 3
Flange 2" 150 lb RF, ASME B16.5/Alloy C22 (2.4602) solid	L 4
Flange 2" 300 lb RF, ASME B16.5/316/316L	L 5
Flange 2" 300 lb RF, ASME B16.5/Alloy C22 (2.4602) solid	L 6
Flange 2" 300 lb RF, ASME B16.5/316/316L, with Alloy C22 (2.4602) coating	L 7
Flange 2" 300 lb ST (small tongue), ASME B16.5/316/316L	L 8
Flange 2" 300 lb RJF, ASME B16.5/316/316L	M 1
Flange 2" 300 lb LM (large male), ASME B16.5/316/316L	M 2
Flange 2" 300 lb SG, ASME B16.5/316/316L	M 3
Flange 2" 300 lb LG, ASME B16.5/316/316L	M 4
Flange 2" 600 lb RF, ASME B16.5/316/316L	M 5
Flange 2" 600 lb RF, ASME B16.5/316/316L, with Alloy C22 (2.4602) coating	M 6
Flange 2" 600 lb RJF, ASME B16.5/316/316L	M 7
Flange 2" 900 lb RF, ASME B16.5/316/316L	M 8
Flange 2" 900 lb RJF, ASME B16.5/316/316L	N 1
Flange 2" 1 500 lb RF, ASME B16.5/316/316L	N 2
Flange 2" 1 500 lb RJF, ASME B16.5/316/316L	N 3
Flange 2" 1 500 lb LT, ASME B16.5/Alloy C22 (2.4602) solid	N 4
Flange 2" 1 500 lb LM, ASME B16.5/316/316L	N 5
Flange 2" 2 500 lb RJF, ASME B16.5/316/316L	N 6
Flange 2½" 150 lb RF, ASME B16.5/316/316L	N 7
Flange 2½" 300 lb RF, ASME B16.5/316/316L	N 8
Flange 2½" 600 lb RF, ASME B16.5/316/316L	P 1
Flange 2½" 900 lb RF, ASME B16.5/316/316L	P 2
Flange 2½" 2 500 lb RJF, ASME B16.5/316/316L	P 3
Flange 3" 150 lb RF, ASME B16.5/316/316L	P 4
Flange 3" 150 lb RF, ASME B16.5/Alloy C22 (2.4602) solid	P 5
Flange 3" 300 lb RF, ASME B16.5/316/316L	P 6
Flange 3" 300 lb RJF, ASME B16.5/316/316L	P 7
Flange 3" 300 lb LT, ASME B16.5/316/316L	P 8
Flange 3" 600 lb RF, ASME B16.5/316/316L	R 1
Flange 3" 600 lb RF, ASME B16.5/Alloy C22 (2.4602) solid	R 2
Flange 3" 600 lb RF, ASME B16.5/316/316L, with Alloy C22 (2.4602) coating	R 3
Flange 3" 600 lb RJF, ASME B16.5/316/316L	R 4
Flange 3" 900 lb RF, ASME B16.5/316/316L	R 5
Flange 3" 900 lb RJF, ASME B16.5/316/316L	R 6
Flange 3" 1 500 lb RF, ASME B16.5/316/316L	R 7
Flange 3" 1 500 lb RJF, ASME B16.5/316/316L	R 8
Flange 3" 2 500 lb RF, ASME B16.5/316/316L	S 1
Flange 3" 2 500 lb RJF, ASME B16.5/316/316L	S 2
Flange 4" 150 lb RF, ASME B16.5/316/316L	S 3
Flange 4" 150 lb RF, ASME B16.5/Alloy C22 (2.4602) solid	S 4
Flange 4" 150 lb RJF, ASME B16.5/316/316L	S 5
Flange 4" 300 lb RF, ASME B16.5/316/316L	S 6
Flange 4" 300 lb RF, ASME B16.5/Alloy C22 (2.4602) solid	S 7

SITRANS LVL200 Vibrating point level switch, high temperature and pressure design

7ML5748-

Detects level and material in liquids and slurries in extreme environments. Extension options to 3 m (9.84 ft).

Flange 4" 300 lb LT, ASME B16.5/316/316L	S 8
Flange 4" 600 lb RF, ASME B16.5/316/316L	T 1
Flange 4" 600 lb RF, ASME B16.5/Alloy C22 (2.4602) solid	T 2
Flange 4" 600 lb RJF, ASME B16.5/316/316L	T 3
Flange 4" 900 lb RF, ASME B16.5/316/316L	T 4
Flange 4" 900 lb RJF, ASME B16.5/316/316L	T 5
Flange 4" 900 lb LT, ASME B16.5/316/316L	T 6
Flange 4" 1 500 lb RF, ASME B16.5/316/316L	T 7
Flange 4" 1 500 lb RJF, ASME B16.5/316/316L	T 8
Flange 4" 1 500 lb LT, ASME B16.5/316/316L	U 1
Flange 5" 150 lb RF, ASME B16.5/316/316L	U 2
Flange 5" 300 lb RF, ASME B16.5/316/316L	U 3
Flange 5" 600 lb RJF, ASME B16.5/316/316L	U 4
Flange 6" 150 lb RF, ASME B16.5/316/316L	U 5
Flange 6" 300 lb RF, ASME B16.5/316/316L	U 6
Flange 6" 300 lb LT, ASME B16.5/316/316L	U 7
Flange DN 50 30K RF, JIS/316/316L	U 8
Flange DN 50 40K RF, JIS/316/316L	V 1
Flange DN 65 40 K RF, JIS/316/316L	V 2
Mobrey flange PN 16 Form A/316/316L	V 3
Mobrey flange PN 16 Form E/316/316L	V 4
Thread R1 PN 160, EN 10226-1/Inconel 718 (2.4668) ¹⁴⁾	W 1
Thread R1 PN 100, EN 10226-1/316L ¹⁵⁾	W 2
Gas-tight seal/Process temperature	
With gas-tight seal/-196 ... +450 °C (-321 ... +842 °F)	1
Without/-196 ... +450 °C (-321 ... +842 °F)	2
Electronics	
Relay (2 x SPDT)	1
20 ... 72 V DC/20 ... 253 V AC (5A)	2
Transistor (NPN/PNP) 9.6 ... 55 V DC	3
Two-wire (8/16 mA) 9.6 ... 35 V DC	4
Relay (2 x SPDT)	4
20 ... 72 V DC/20 ... 253 V AC (5A), with SIL qualification	5
Transistor (NPN/PNP) 9.6 ... 55 V DC, with SIL qualification	6
Two-wire (8/16 mA) 9.6 ... 35 V DC, with SIL qualification	6
Housing/Cable entry	
Plastic single chamber/IP66/IP67/M20 x 1.5 gland PA black (ø5 ... 9 mm)	A
Plastic single chamber/IP66/IP67/½" NPT gland PA black (ø5 ... 9 mm)	B
Aluminum IP66/IP67/M20 x 1.5 gland PA black (ø5 ... 9 mm)	C
Aluminum IP66/IP67/½" NPT gland PA black (ø5 ... 9 mm)	D
Stainless steel single chamber (precision casting)/ IP66/IP67/M20 x 1.5	E
Stainless steel single chamber (precision casting)/ IP66/IP67/½" NPT gland PA black (ø5 ... 9 mm)	F
Stainless steel single chamber (electropolished)/ IP66/IP67/M20 x 1.5 gland PA black (ø5 ... 9 mm)	G
Stainless steel single chamber (electropolished)/ IP66/IP67/½" NPT gland PA black (ø5 ... 9 mm)	H
Aluminium IP66/IP67/M20 x 1.5 blind plug	J
Aluminium IP66/IP67/½" NPT blind plug	K
Stainless steel single chamber (precision casting)/IP66/IP67/M20 x 1.5 blind plug	L

4

Selection and ordering data	Article No.	Article No.
SITRANS LVL200 Vibrating point level switch, high temperature and pressure design Detects level and material in liquids and slurries in extreme environments. Extension options to 3 m (9.84 ft).	7ML5748-	
Stainless steel single chamber (precision casting)/ IP66/IP67/1/2" NPT blind plug Stainless steel single chamber (electropolished)/ IP66/IP67/M20 x 1.5 blind plug Stainless steel single chamber (electropolished)/ IP66/IP67/1/2" NPT blind plug	M N P	
Rigid Extension Compact Compact version, 77 mm	C 1	
Rigid Extension 316L 200 ... 500 mm 501 ... 1 000 mm 1 001 ... 1 500 mm 1 501 ... 2 000 mm 2 001 ... 2 500 mm 2 501 ... 3 000 mm	A 0 A 1 A 2 A 3 A 4 A 5	
Rigid Extension Alloy C22 200 ... 500 mm 501 ... 1 000 mm 1 001 ... 1 500 mm 1 501 ... 2 000 mm 2 001 ... 2 500 mm 2 501 ... 3 000 mm	B 0 B 1 B 2 B 3 B 4 B 5	
Further designs	Order code	
Please add "-Z" to Article No. and specify Order code(s).		
Cleaning including Certificate(oil, grease, and silicone free).	W01	
Enter the total insertion length in plain text description.	Y01	
Identification label (measurement loop) stainless steel.	Y17	
Identification Label (measurement loop) foil.	Y18	
Output switching delay (1 ... 60 s)/default is 1 s	Y36	
NACE0175 to 3.1 Material Certificate for material (EN 10204 NACE MR 0175) Note: not available with some Process connection options.	D07	
Material Inspection 3.1-Inspection certificate for material (EN 10204)	C05	
Acceptance test Certificate 2.2 for material (EN 10204)	C15	
Dye penetration test, results confirmed via a 3.1 certificate/instrument (EN 10204)	C13	
3.1-Inspection certificate for instrument with test data (EN 10204)	C25	
Quality and test plan	C26	
Inspection certificate 3.1 (EN 10204) - device and pressure test	C31	
Helium leak test + 3.1 certificate/instrument	C32	
Spare Parts and Accessories SITRANS SCSC single channel signal conditioner and remote test SITRANS TCSC two channel signal conditioner and remote test		7ML5760-.....-..... 7ML5761-.....-.....
Operating Instructions All literature is available to download for free, in a range of languages, at http://www.siemens.com/processinstrumentation/documentation		
		<ol style="list-style-type: none"> 1) Not available with Process Connection options A0 and A2. 2) Available only with Rigid extension option C1. 3) Available only with 316L Process Connection and Rigid extension options. 4) Available only with Alloy C22 Rigid extension options. 5) Available only with Electronic options 3 and 6. 6) Available only with Housing/Cable entry options J, K, L, M. 7) Available only with Electronic option 6. 8) Available only with Electronic options 1, 2, and 4. 9) Available only with Gas tight seal/Process temperature option 1. 10) Not available with Housing/Cable entry options G, H, N, P. 11) Available only with Housing/Cable entry options J, K, L, M, N, P. 12) Not available with Housing/Cable entry options A and B. 13) Not available with Housing/Cable entry options A, B, G, H, N, P. 14) Available only with Version/material option 1. 15) Available only with Version/material option 2.

Level measurement

Point level measurement
Vibrating switches

SITRANS LVL200

Selection and ordering data

Article No.

Article No.

SITRANS SCSC, single channel, signal conditioner

7ML5760-

Provides power and relay output for one LVL200 vibrating switch, 8/16 mA electronics design. Provides remote test of any LVL200 device.

➤ Click on the Article No. for the online configuration in the PIA Life Cycle Portal.

Approvals

For Ex-free area
ATEX II (1) G/D [Ex ia Ga/Da] IIC/IIIC, I (M1) [Ex ia Ma] I
ATEX II (1) G/D (Ex ia Ga/Da) IIC/IIIC, I (M1) (Ex ia Ma) I + WHG
IEC [Ex ia Ga] IIC, [Ex ia Da] IIIC, [Ex ia Ma] I
IEC (Ex ia Ga) IIC, (Ex ia Da) IIIC, (Ex ia Ma) I + WHG
Ex-free area (incl. EAC approval)

1 A
1 D
1 E
1 H
1 J
2 A

SIL qualification

Without
With

1
2

Version

Single-channel (8/16 mA) for level detection
Single channel (8/16 mA), level detection with fail safe relay

1
2

Housing/cable entry

Plastic/IP20

A

Terminal block connection

Detachable 2.5 mm²/ Ex sensor: 2 x blue; output and operating voltage: 2 x black
Detachable 2.5 mm²/ sensor: 2 x black; output and operating voltage: 2 x black

A
B

Language

English
German

0
1

Operating Instructions

All literature is available to download for free, in a range of languages, at

<http://www.siemens.com/processinstrumentation/documentation>

SITRANS TCSC, dual channel, signal conditioner

7ML5761-

Provides power and relay output for two LVL200 vibrating switch, 8/16 mA electronics design. Provides remote test of any LVL200 device.

➤ Click on the Article No. for the online configuration in the PIA Life Cycle Portal.

Approvals

For Ex-free area¹⁾
ATEX II (1) G/D [Ex ia Ga/Da] IIC/IIIC, I (M1) [Ex ia Ma] I²⁾
ATEX II (1) G/D (Ex ia Ga/Da) IIC/IIIC, I (M1) (Ex ia Ma) I + WHG
IEC [Ex ia Ga] IIC, [Ex ia Da] IIIC, [Ex ia Ma] I²⁾
IEC (Ex ia Ga) IIC, (Ex ia Da) IIIC, (Ex ia Ma) I + WHG
Ex-free area (incl. EAC approval)

1 A
1 D
1 E
1 H
1 J
2 A

SIL qualification

Without
With

1
2

Version

Double-channel (8/16 mA) for level detection

1

Housing/cable entry

Plastic/IP20

A

Terminal block connection

Detachable 2.5 mm²/ Ex sensor: 2 x blue; output and operating voltage: 2 x black
Detachable 2.5 mm²/ sensor: 2 x black; output and operating voltage: 2 x black

A
B

Language

English
German

0
1

Operating Instructions

All literature is available to download for free, in a range of languages, at

<http://www.siemens.com/processinstrumentation/documentation>

1) Available only with terminal block connection option B.

2) Available only with terminal block connection option A.

Options

LVL200 threaded welded socket

G^{3/4}" A/316L

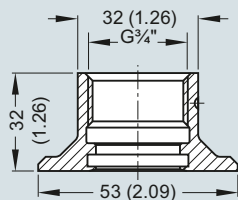

G1" A/316L

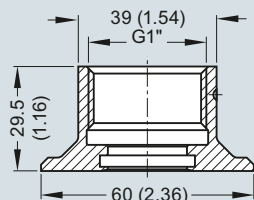

Lock fitting

LVL200 extended 64 bar

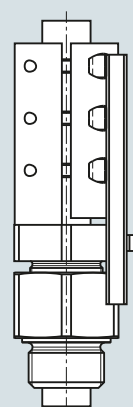

LVL200 extended 16 bar

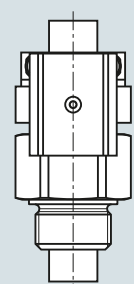

LVL200 extended unpressurized

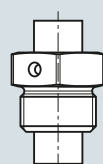

SITRANS LVL200 welded socket and lock fitting, dimensions in mm (inch)

SITRANS SCSC and TCSC LVL test conditioner

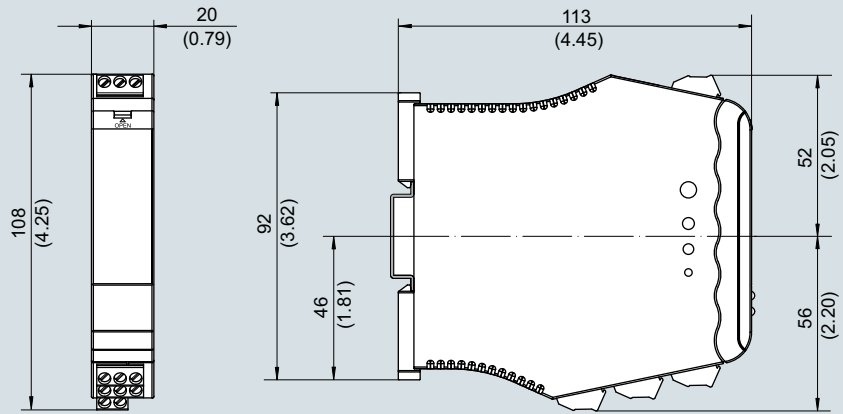

SITRANS SCSC and SITRANS TCSC LVL Test Conditioners, dimensions in mm (inch)

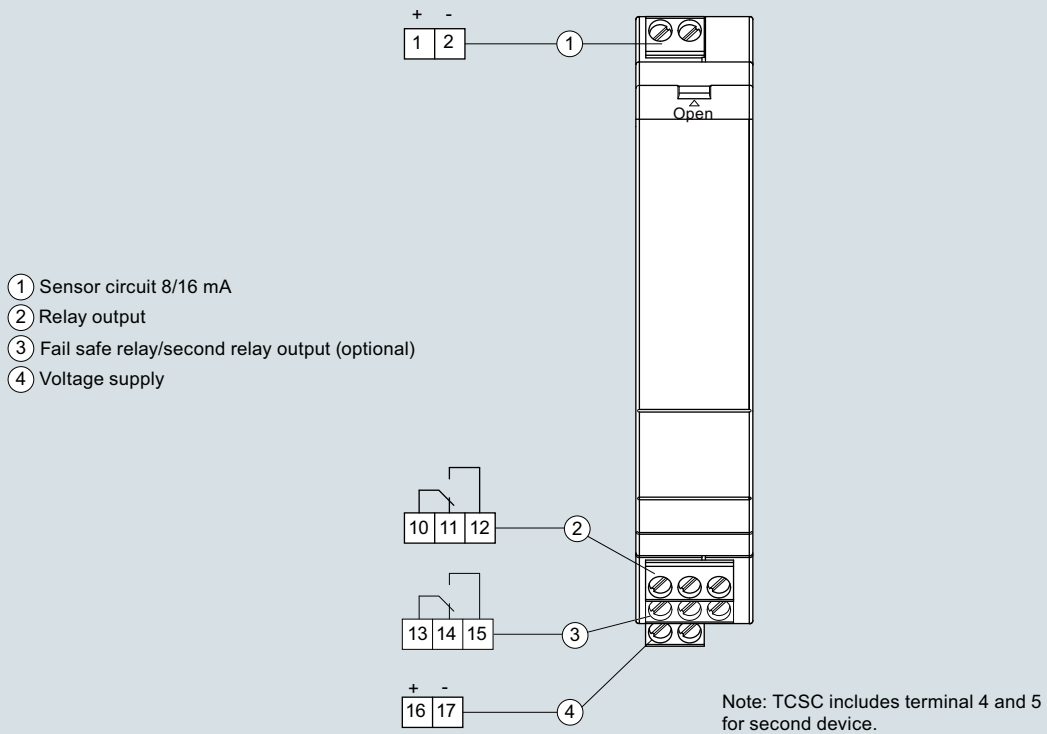

SITRANS SCSC and SITRANS TCSC LVL Test Conditioner connections

Level measurement

Point level measurement
Vibrating switches

SITRANS LVL200

Characteristic curves

Ambient/Process temperature

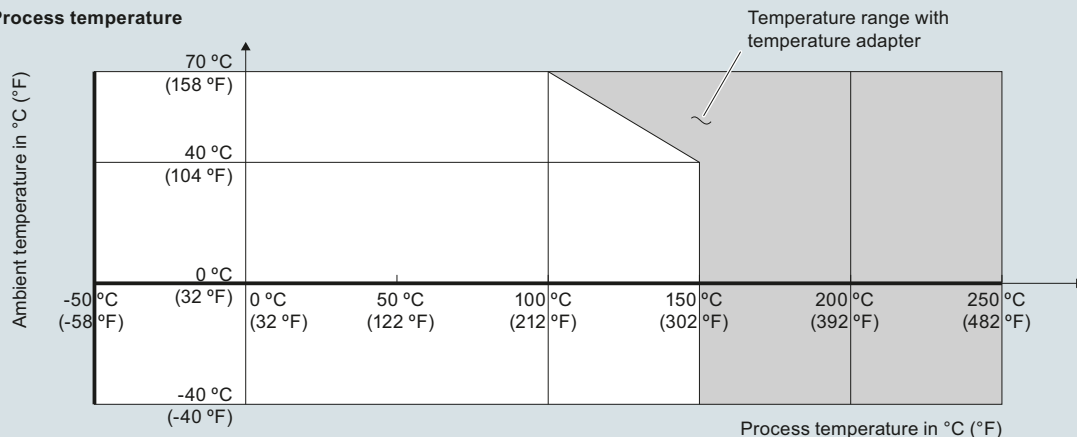

Process pressure with switch position 0.7 g/cm³ (mode switch)

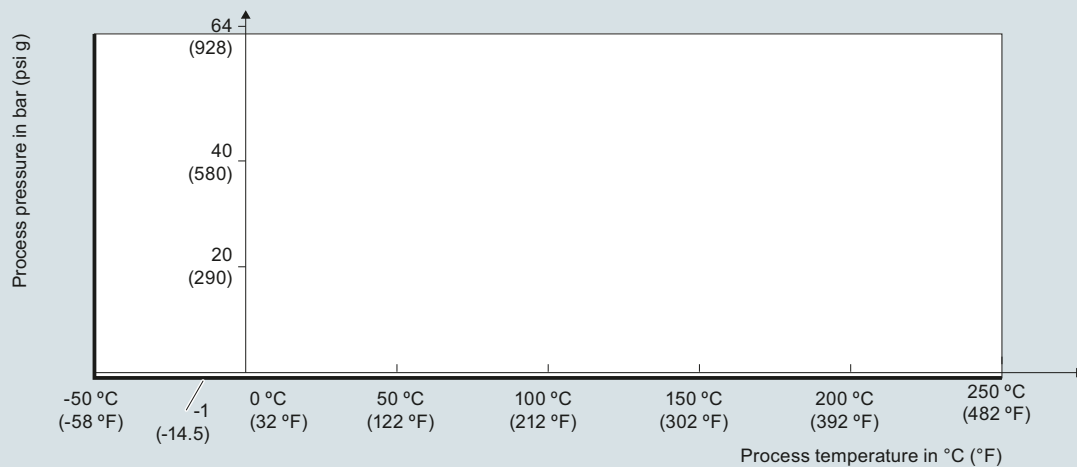

Process pressure with switch position 0.5 g/cm³ (mode switch)

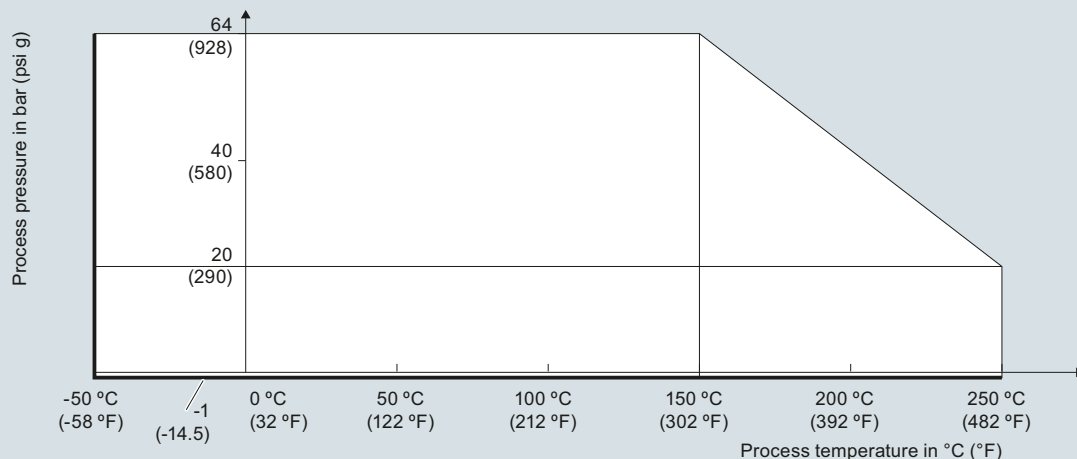

SITRANS LVL200 process pressure/process temperature/ambient temperature derating curves

4

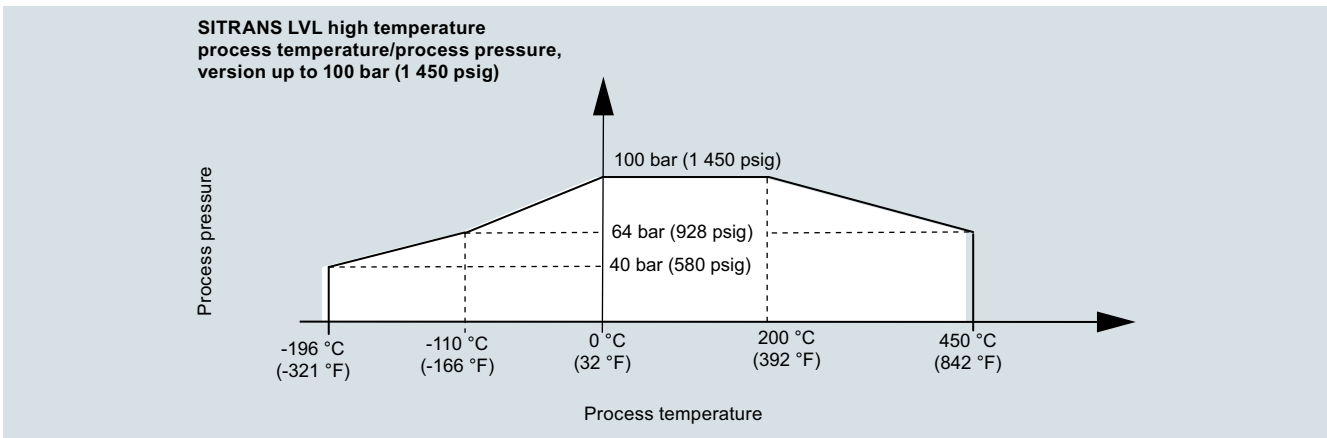

SITRANS LVL200 high temperature process temperature/process pressure curve, version up to 100 bar (1 450 psig)

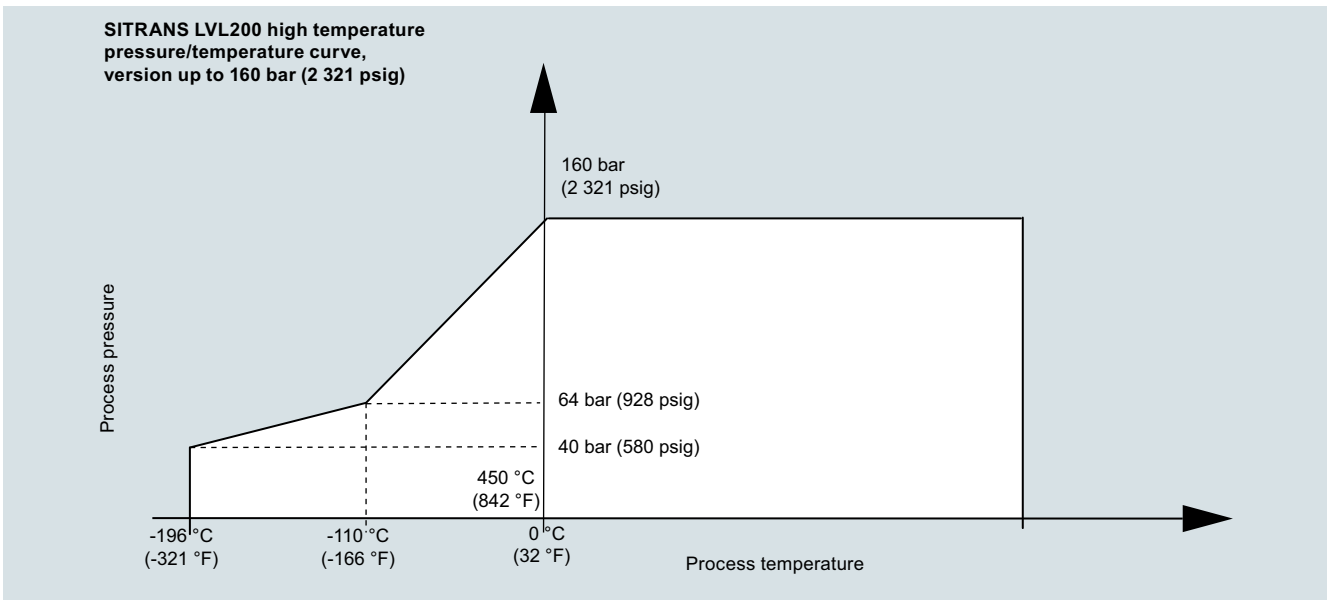

SITRANS LVL200 high temperature pressure/temperature curve, version up to 160 bar (2 321 psig)

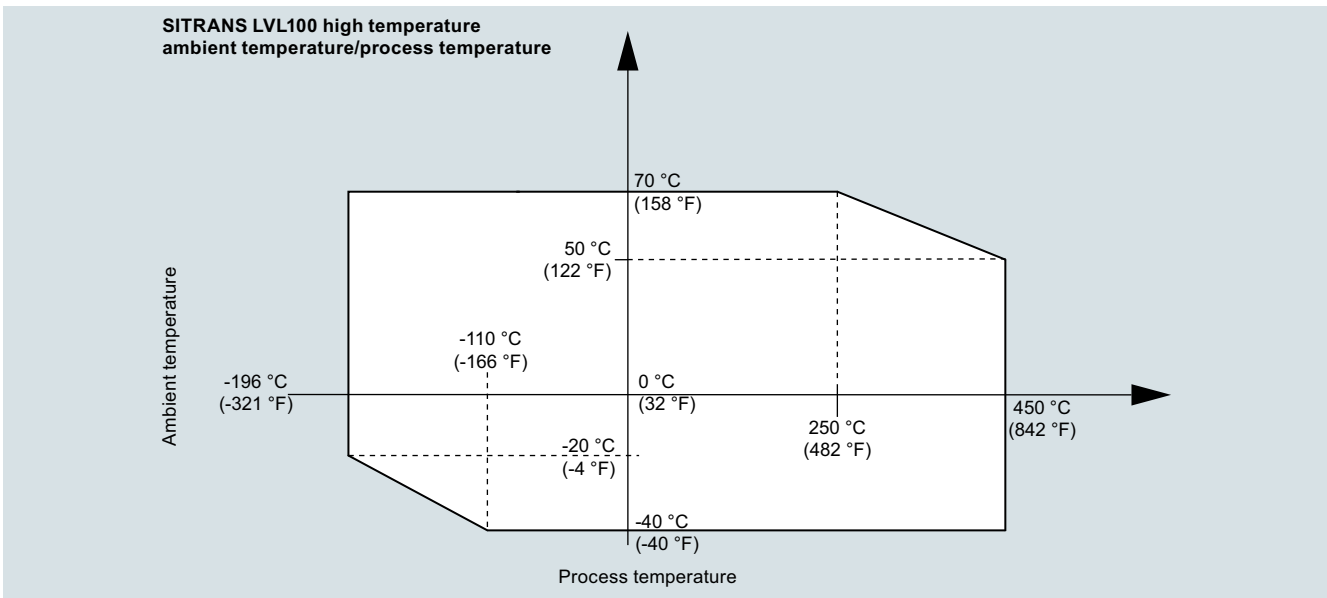

SITRANS LVL200 high temperature ambient temperature/process temperature

4

Level measurement

Point level measurement

Vibrating switches

SITRANS LVL200

Dimensional drawings

SITRANS LVL200, housing

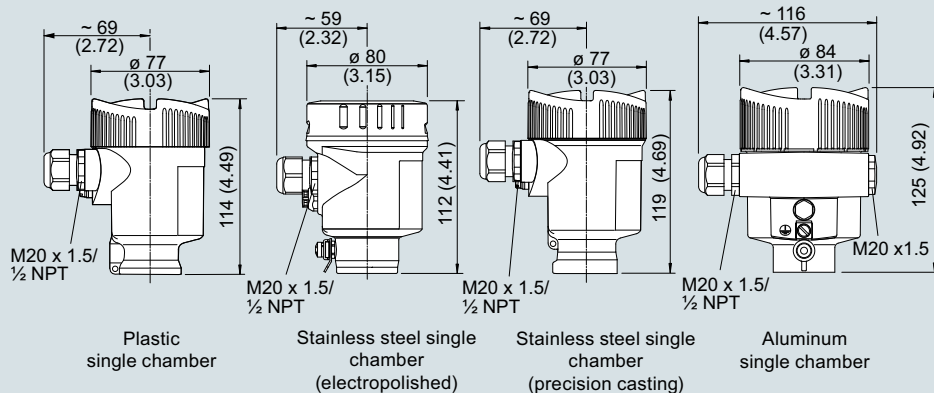

SITRANS LVL200 housing, dimensions in mm (inch)

SITRANS LVL200 standard

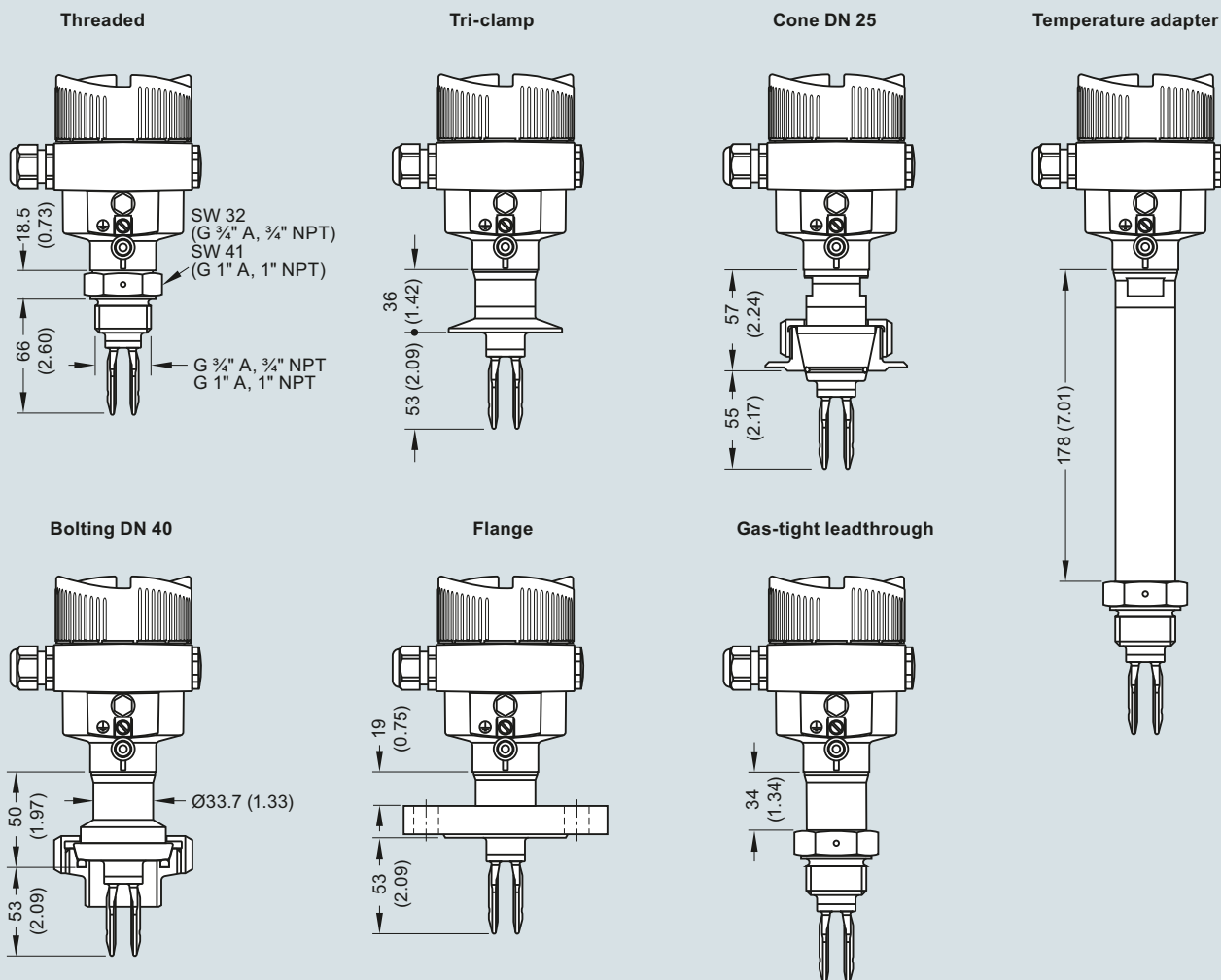

SITRANS LVL200 (standard), dimensions in mm (inch)

SITRANS LVL200 extended

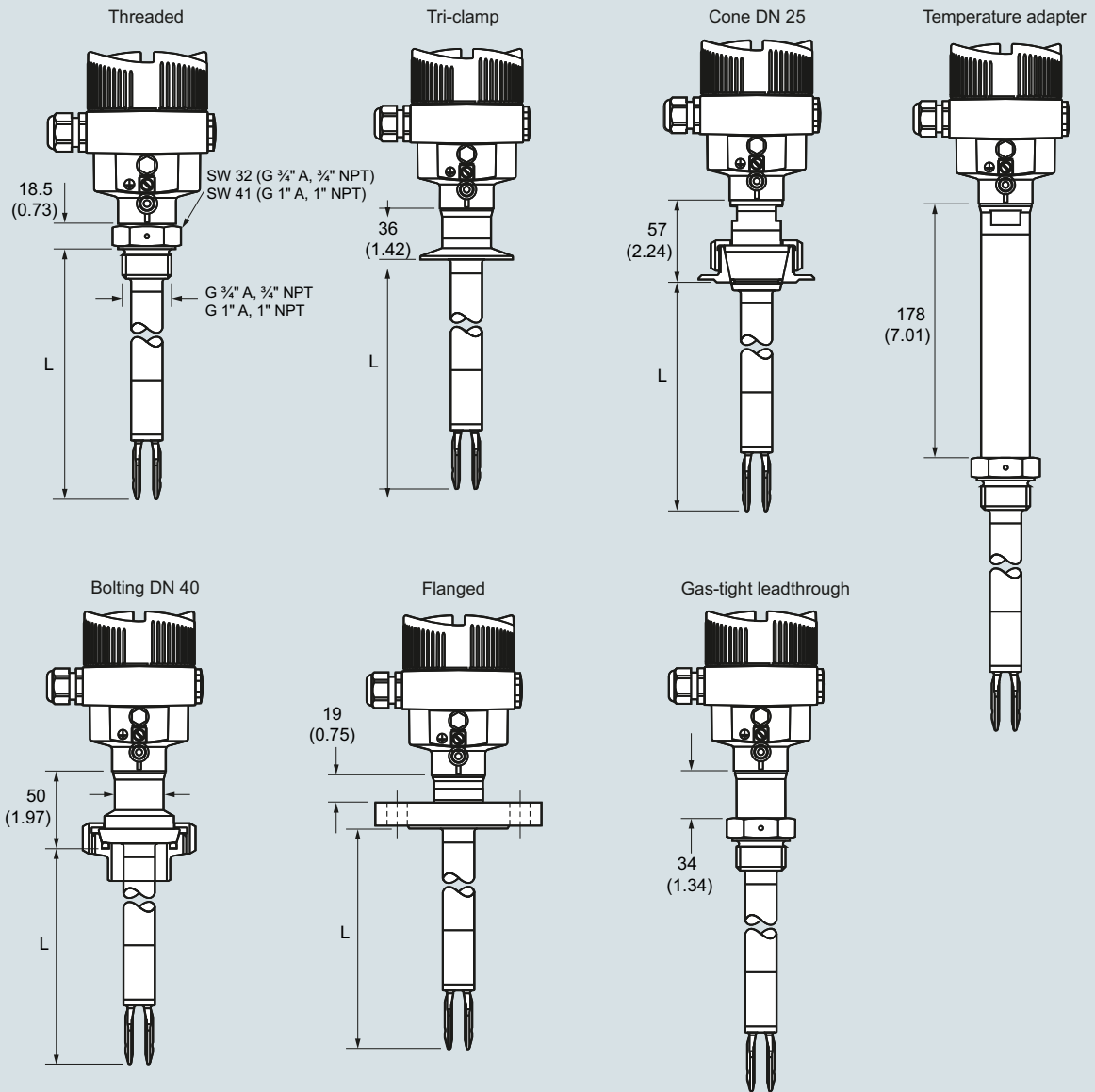

Sensor length (L)

316L, Alloy C22 (2.4602)	80 ... 6 000 mm (3.15 ... 236.2 inch)
Enamelled	80 ... 1 500 mm (3.15 ... 59.06 inch)
316L, ECTFE coated	80 ... 3 000 mm (3.15 ... 118.1 inch)
316L, PFA coated	80 ... 4 000 mm (3.15 ... 157.5 inch)

SITRANS LVL200 (extended), dimensions in mm (inch)

Level measurement

Point level measurement

Vibrating switches

SITRANS LVL200

SITRANS LVL200 high temperature, compact version

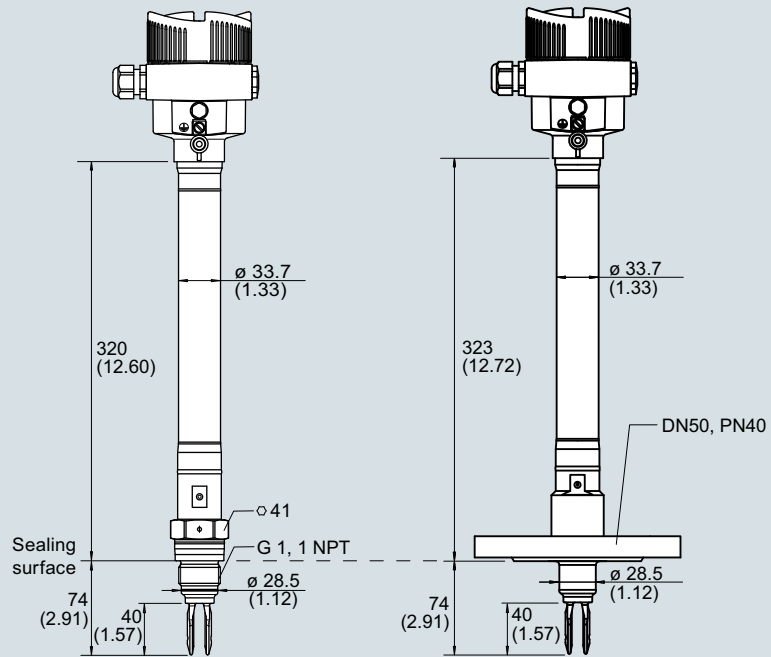

SITRANS LVL200 high temperature, compact version, dimensions in mm (inch)

SITRANS LVL200 high temperature, tube version

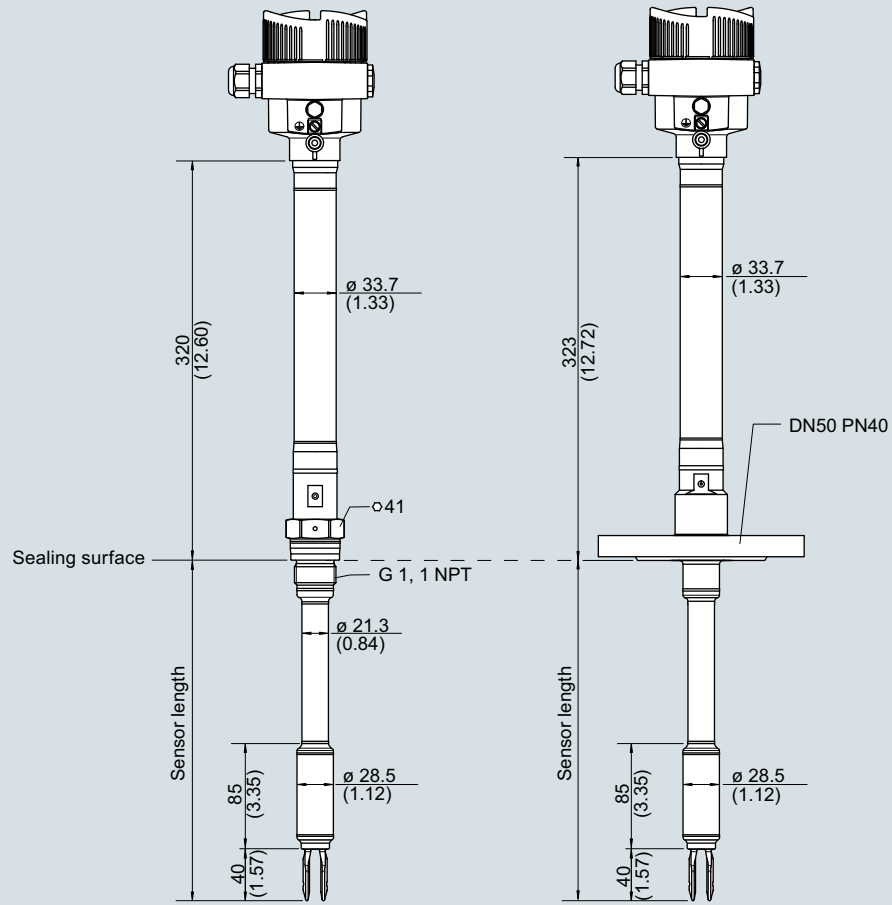

SITRANS LVL200 high temperature, tube version, dimensions in mm (inch)



Level measurement

Point level measurement

Vibrating switches

SITRANS LVL200

Circuit diagrams

**SITRANS LVL200S, LVL200E
Relay (DPDT)**

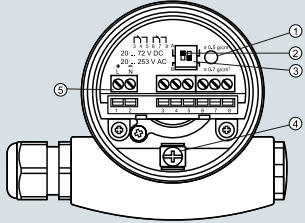

- ① Control lamp
- ② DIL switch for characteristics reversal
- ③ DIL switch for sensitivity adjustment
- ④ Ground terminal
- ⑤ Connection terminals

**SITRANS LVL200H
Relay (DPDT)**

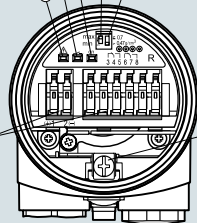

- ① Control lamp - fault indication (red)
- ② Control lamp - Switching status (yellow)
- ③ Control lamp - Operating status (green)
- ④ Mode switch for selecting the switching behaviour (min./max.)
- ⑤ DIL switch for sensitivity adjustment
- ⑥ Ground terminal
- ⑦ Connection terminals

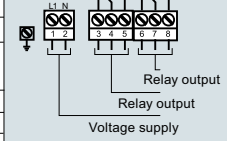

Contactless

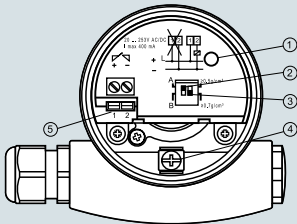

- ① Control lamp
- ② DIL switch for mode adjustment
- ③ DIL switch for switching point adaptation
- ④ Ground terminal
- ⑤ Connection terminals

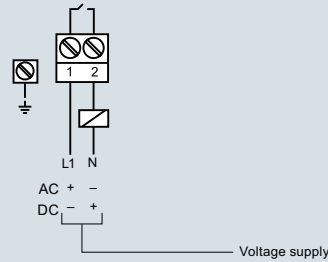

NAMUR

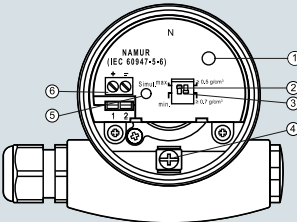

- ① Control lamp
- ② DIL switch for characteristics reversal
- ③ DIL switch for sensitivity adjustment
- ④ Ground terminal
- ⑤ Simulation key
- ⑥ Connection terminals

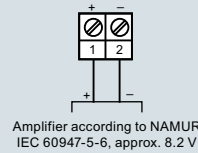

**SITRANS LVL200S, LVL200E
Transistor (NPN/PNP)**

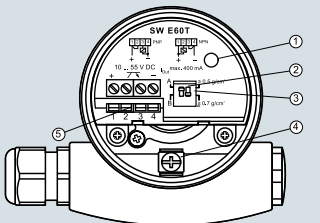

- ① Control lamp
- ② DIL switch for mode adjustment
- ③ DIL switch for switching point
- ④ Ground terminal
- ⑤ Connection terminals

**SITRANS LVL200H,
Transistor (NPN/PNP)**

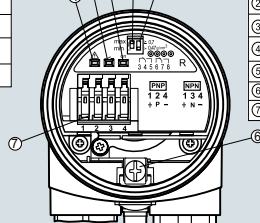

- ① Control lamp - fault indication (red)
- ② Control lamp - Switching status (yellow)
- ③ Control lamp - Operating status (green)
- ④ Mode switch for selecting the switching behaviour (min./max.)
- ⑤ DIL switch for sensitivity adjustment
- ⑥ Ground terminal
- ⑦ Connection terminals

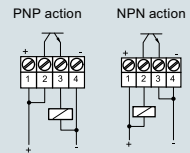

**SITRANS LVL200S, LVL200E
8/16 mA**

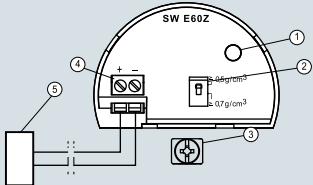

- ① Control lamp
- ② DIL switch for sensitivity adjustment
- ③ Ground terminal
- ④ Connection terminals
- ⑤ Processing system or PLC

SITRANS LVL200H 8/16 mA

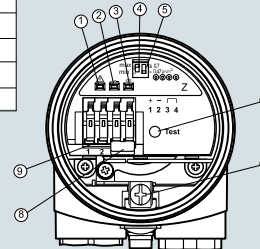

- ① Control lamp - fault indication (red)
- ② Control lamp - switching status (yellow)
- ③ Control lamp - operating status (green)
- ④ Mode switch for selecting the switching behavior (min./max.)
- ⑤ DIL switch for sensitivity behavior (min./max.)
- ⑥ Test key
- ⑦ Ground terminal
- ⑧ Connector block
- ⑨ Connection terminals

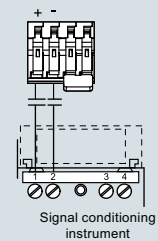

SITRANS LVL200 connections

4