

Temperature measurement

Temperature transmitters

Compact and head transmitters

SITRANS TH200 (4 to 20 mA, universal)

Overview



Ultra flexible - with the universal SITRANS TH200 transmitter

- 2-wire device for 4 to 20 mA
- Mounting in the connection head of the temperature sensor
- Universal input for virtually any type of temperature sensor
- Configurable over PC

Benefits

- Compact design
- Flexible mounting and center hole allow you to select your preferred type of installation
- Galvanic isolation
- Test sockets for multimeters
- Diagnostics LED (green/red)
- Sensor monitoring open circuits and short-circuits
- Self-monitoring
- Configuration status stored in EEPROM
- SIL2 (with order note C20), SIL2/3 (with C23)
- Expanded diagnostic functions, such as slave pointer, operating hours counter, etc.
- Special characteristic
- Electromagnetic compatibility to EN 61326 and NE21

Application

SITRANS TH200 transmitters can be used in all industrial sectors. Its compact size means that it can be installed in connection heads of type B or larger. The following sensors/signal sources can be connected over their universal input module:

- Resistance thermometer (2, 3, 4-wire connection)
- Thermocouples
- Resistance-based sensors and DC voltage sources

The output signal is a direct current from 4 to 20 mA in accordance with the sensor characteristic.

Transmitters of the "intrinsically safe" type of protection can be installed within potentially explosive atmospheres. The devices meet the directive 2014/34/EU (ATEX) as well as the FM and CSA requirements.

Function

The SITRANS TH200 is configured over a PC. A USB or RS 232 modem is linked to the output terminals for this purpose. The configuration data can now be edited using the SIPROM T software tool. The configuration data are then permanently stored in the non-volatile memory (EEPROM).

Once the sensors and power supply have been correctly connected, the transmitter outputs a temperature-linear output signal and the diagnostics LED displays a green light. In the case of a sensor break, the LED flashes red, an internal device fault is indicated by a steady red light.

The test socket can be used to connect an ammeter at any time for monitoring purposes and plausibility checks. The output current can be read without any interruption, or even without opening the current loop.

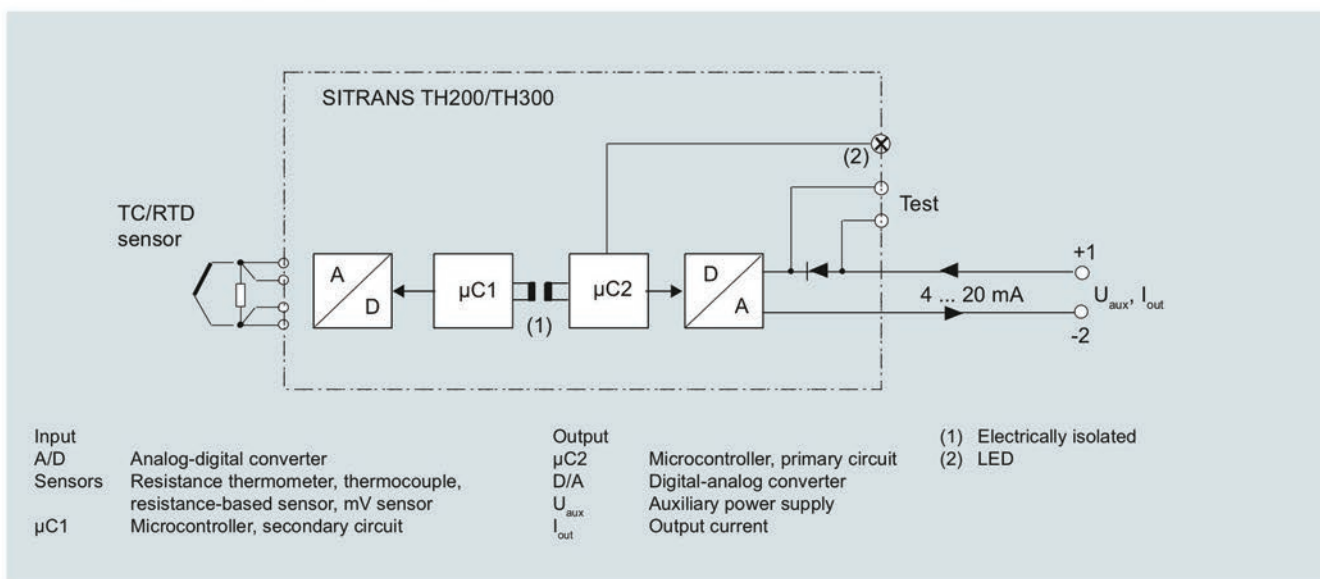

SITRANS TH200 function diagram

Technical specifications

Input

Resistance thermometer

Measured variable	Temperature
Sensor type	Pt25 ... Pt1000
• According to IEC 60751	Pt25 ... Pt1000
• Acc. to JIS C 1604; $\alpha = 0.00392 \text{ K}^{-1}$	Ni25 ... Ni1000
• According to IEC 60751	Via special characteristic (max. 30 points)
• Special type	
Sensor factor	0.25 ... 10 (adaptation of the basic type, e.g. Pt100 to version Pt25 ... 1000)
Units	°C or °F
Connection	
• Standard connection	1 resistance thermometer (RTD) in 2-wire, 3-wire or 4-wire connection
• Averaging	2 identical resistance thermometers in 2-wire connection for generation of average temperature
• Differentiation	2 identical resistance thermometers (RTD) in 2-wire connection (RTD 1 – RTD 2 or RTD 2 – RTD 1)
Connection	
• 2-wire connection	Line resistance can be configured $\leq 100 \Omega$ (loop resistance)
• 3-wire connection	No trim necessary
• 4-wire connection	No trim necessary
Sensor current	$\leq 0.45 \text{ mA}$
Response time	$\leq 250 \text{ ms}$ for 1 sensor with break monitoring
Break monitoring	Always active (cannot be switched off)
Short-circuit monitoring	Can be switched on/off (default value: ON)
Measuring range	Assignable (see "Digital measuring error" table)
Min. measuring span	10 °C (18 °F)
Characteristic curve	Temperature-linear or special characteristic
Resistance-based sensor	
Measured variable	Actual resistance
Sensor type	Resistance-based, potentiometers
Units	Ω
Connection	
• Standard connection	1 resistance-based sensor (R) in 2-wire, 3-wire or 4-wire connection
• Averaging	2 resistance-based sensors in 2-wire connection for averaging
• Differentiation	2 resistance thermometers in 2-wire connection (R1 – R2 or R2 – R1)
Connection	
• 2-wire connection	Line resistance can be configured $\leq 100 \Omega$ (loop resistance)
• 3-wire connection	No trim necessary
• 4-wire connection	No trim necessary
Sensor current	$\leq 0.45 \text{ mA}$
Response time	$\leq 250 \text{ ms}$ for 1 sensor with break monitoring
Break monitoring	Always active (cannot be switched off)
Short-circuit monitoring	Can be switched on/off (default value: OFF)
Measuring range	Assignable max. 0 ... 2200 Ω (see "Digital measuring error" table)
Min. measuring span	5 Ω ... 25 Ω (see "Digital measuring error" table)
Characteristic curve	Resistance-linear or special characteristic

Thermocouples

Measured variable	Temperature
Sensor type (thermocouples)	Pt30Rh-Pt6Rh acc. to IEC 584
• Type B	W5%-Re acc. to ASTM 988
• Type C	W3%-Re acc. to ASTM 988
• Type D	NiCr-CuNi acc. to IEC 584
• Type E	Fe-CuNi acc. to IEC 584
• Type J	NiCr-Ni acc. to IEC 584
• Type K	Fe-CuNi acc. to DIN 43710
• Type L	NiCrSi-NiSi acc. to IEC 584
• Type N	Pt13Rh-Pt acc. to IEC 584
• Type R	Pt10Rh-Pt acc. to IEC 584
• Type S	Cu-CuNi acc. to IEC 584
• Type T	Cu-CuNi acc. to DIN 43710
• Type U	
Units	°C or °F
Connection	
• Standard connection	1 thermocouple (TC)
• Averaging	2 thermocouples (TC)
• Differentiation	2 thermocouples (TC) (TC1 – TC2 or TC2 – TC1)
Response time	$\leq 250 \text{ ms}$ for 1 sensor with break monitoring
Break monitoring	Can be switched off
Reference junction compensation	
• Internal	With integrated Pt100 resistance thermometer
• External	With external Pt100 IEC 60751 (2-wire or 3-wire connection)
• External fixed	Reference junction temperature can be set as fixed value
Measuring range	Assignable (see "Digital measuring error" table)
Min. measuring span	Min. 40 ... 100 °C (72 ... 180 °F) (see "Digital measuring error" table)
Characteristic curve	Temperature-linear or special characteristic
mV sensor	
Measured variable	DC voltage
Sensor type	DC voltage source (DC voltage source possible over an externally connected resistor)
Units	mV
Response time	$\leq 250 \text{ ms}$ for 1 sensor with break monitoring
Break monitoring	Can be switched off
Measuring range	-10 ... +70 mV -100 ... +1100 mV
Min. measuring span	2 mV or 20 mV
Overload capability of the input	-1.5 ... +3.5 V DC
Input resistance	$\geq 1 \text{ M}\Omega$
Characteristic curve	Voltage-linear or special characteristic

Temperature measurement

Temperature transmitters

Compact and head transmitters

SITRANS TH200 (4 to 20 mA, universal)

Output	
Output signal	4 ... 20 mA, 2-wire
Auxiliary power	11 ... 35 V DC (to 30 V with Ex ia and ib; to 32 V with Ex nA/nL/ic)
Max. load	$(U_{aux} - 11 \text{ V})/0.023 \text{ A}$
Overrange	3.6 ... 23 mA, infinitely adjustable (default range: 3.80 mA ... 20.5 mA)
Error signal (e.g. following sensor fault) (conforming to NE43)	3.6 ... 23 mA, infinitely adjustable (default value: 22.8 mA)
Sample cycle	0.25 s nominal
Damping	Software filter 1st order 0 ... 30 s (parameterizable)
Protection	Against reverse polarity
Galvanic isolation	Input against output 2.12 kV DC (1.5 kV _{rms} AC)
Measuring accuracy	
Digital measuring error	See "Digital measuring error" table
Reference conditions	
• Auxiliary power	24 V ± 1 %
• Load	500 Ω
• Ambient temperature	23 °C
• Warming-up time	> 5 min
Error in the analog output (digital/analog converter)	< 0.025 % of measuring span
Error due to internal reference junction	< 0.5 °C (0.9 °F)
Effect of ambient temperature	
• Analog measuring error	0.02 % of meas. span/10 °C (18 °F)
• Digital measuring error	
- with resistance thermometers	0.06 °C (0.11 °F)/10°C (18 °F)
- with thermocouples	0.6 °C (1.1 °F)/10°C (18 °F)
Auxiliary power effect	< 0.001 % of meas. span/V
Effect of load impedance	< 0.002 % of meas. span/100 Ω
Long-term drift	
• In the first month	• < 0.02 % of measuring span
• After one year	• < 0.2 % of measuring span
• After 5 years	• < 0.3 % of measuring span
Rated conditions	
<u>Ambient conditions</u>	
Ambient temperature	-40 ... +85 °C (-40 ... +185 °F)
Storage temperature	-40 ... +85 °C (-40 ... +185 °F)
Relative humidity	< 98 %, with condensation
Electromagnetic compatibility	acc. to EN 61326 and NE21
Design	
Material	Molded plastic
Weight	50 g (0.11 lb)
Dimensions	See "Dimensional drawings"
Cross-section of cables	Max. 2.5 mm ² (AWG 13)
Degree of protection according to IEC 60529	
• Enclosure	IP40
• Terminals	IP00

Certificates and approvals	
Explosion protection ATEX	
EC type-examination certificate	PTB 05 ATEX 2040X
• "Intrinsic safety" type of protection	II 1 G Ex ia IIC T6/T4 II 2 (1) G Ex ia/ib IIC T6/T4 II 3(1) G Ex ia/ic IIC T6/T4 II 1D Ex iaD 20 T115 °C
• "Non-sparking and energy-limited equipment" type of protection	II 3 G Ex nL IIC T6/T4 II 3 G Ex nA IIC T6/T4
Explosion protection: FM for USA	
• FM approval	FM 3024169
• Degrees of protection	IS / CI I, II, III / Div 1 / GP ABCDEFG T6, T5, T4 CI I / ZN 0 / AEx ia IIC T6, T5, T4 NI / CI I / Div 2 / GP ABCDFG T6, T5, T4 NI / CI I / ZN 2 / IIC T6, T5, T4
Explosion protection to FM for Canada (cFM _{US})	
• FM approval	FM 3024169C
• Degrees of protection	IS / CI I, II, III / Div 1/ GP ABCDEFG T6, T5, T4 NI / CI I / DIV 2 / GP ABCD T6, T5, T4 NIFW / CI I, II, III / DIV 2 / GP ABCDFG T6, T5, T4 DIP / CI II, III / Div 2 / GP FG T6, T5, T4 CI I / ZN 0 / Ex ia IIC T6, T5, T4 CI I / ZN 2 / Ex nA nL IIC T6, T5, T4
Other certificates	EAC Ex(GOST), NEPSI, IEC, EXPO-LABS
Software requirements for SIPROM T	
PC operating system	Windows ME, 2000, XP, Win 7 and Win 8; in connection with RS 232 modem, also Windows 95, 98 and 98SE

Factory setting:

- Pt100 (IEC 751) in the 3-wire connection
- Measuring range: 0 ... 100 °C (32 ... 212 °F)
- Fault current: 22.8 mA
- Sensor offset: 0 °C (0 °F)
- Damping 0.0 s

Digital measuring error

Resistance thermometer

Input	Measuring range	Minimum measuring span		Digital accuracy	
		°C (°F)	°C (°F)	°C (°F)	°C (°F)
According to IEC 60751					
Pt25	-200 ... +850 (-328 ... +1562)	10	(18)	0.3	(0.54)
Pt50	-200 ... +850 (-328 ... +1562)	10	(18)	0.15	(0.27)
Pt100 ... Pt200	-200 ... +850 (-328 ... +1562)	10	(18)	0.1	(0.18)
Pt500	-200 ... +850 (-328 ... +1562)	10	(18)	0.15	(0.27)
Pt1000	-200 ... +350 (-328 ... +662)	10	(18)	0.15	(0.27)
According to JIS C1604-81					
Pt25	-200 ... +649 (-328 ... +1200)	10	(18)	0.3	(0.54)
Pt50	-200 ... +649 (-328 ... +1200)	10	(18)	0.15	(0.27)
Pt100 ... Pt200	-200 ... +649 (-328 ... +1200)	10	(18)	0.1	(0.18)
Pt500	-200 ... +649 (-328 ... +1200)	10	(18)	0.15	(0.27)
Pt1000	-200 ... +350 (-328 ... +662)	10	(18)	0.15	(0.27)
Ni 25 ... Ni1000	-60 ... +250 (-76 ... +482)	10	(18)	0.1	(0.18)

Resistance-based sensor

Input	Measuring range	Minimum measuring span	Digital accuracy
Resistance	0 ... 390	5	0.05
Resistance	0 ... 2200	25	0.25

Thermocouples

Input	Measuring range	Minimum measuring span		Digital accuracy	
		°C (°F)	°C (°F)	°C (°F)	°C (°F)
Type B	100 ... 1820 (212 ... 3308)	100	(180)	2 ¹⁾	(3.60) ¹⁾
Type C (W5)	0 ... 2300 (32 ... 4172)	100	(180)	2	(3.60)
Type D (W3)	0 ... 2300 (32 ... 4172)	100	(180)	1 ²⁾	(1.80) ²⁾
Type E	-200 ... +1000 (-328 ... +1832)	50	(90)	1	(1.80)
Type J	-200 ... +1200 (-328 ... +2192)	50	(90)	1	(1.80)
Type K	-200 ... +1370 (-328 ... +2498)	50	(90)	1	(1.80)
Type L	-200 ... +900 (-328 ... +1652)	50	(90)	1	(1.80)
Type N	-200 ... +1300 (-328 ... +2372)	50	(90)	1	(1.80)
Type R	-50 ... +1760 (-58 ... +3200)	100	(180)	2	(3.60)
Type S	-50 ... +1760 (-58 ... +3200)	100	(180)	2	(3.60)
Type T	-200 ... +400 (-328 ... +752)	40	(72)	1	(1.80)
Type U	-200 ... +600 (-328 ... +1112)	50	(90)	2	(3.60)

¹⁾ The digital accuracy in the range 100 to 300 °C (212 to 572 °F) is 3 °C (5.4 °F).

²⁾ The digital accuracy in the range 1750 to 2300 °C (3182 to 4172 °F) is 2 °C (3.6 °F).

mV sensor

Input	Measuring range	Minimum measuring span	Digital accuracy
mV sensor	-10 ... +70	2	40
mV sensor	-100 ... +1100	20	400

The digital accuracy is the accuracy after the analog/digital conversion including linearization and calculation of the measured value.

An additional error is generated in the output current 4 to 20 mA as a result of the digital/analog conversion of 0.025 % of the set span (digital-analog error).

The total error under reference conditions at the analog output is the sum from the digital error and the digital-analog error (poss. with the addition of reference junction errors in the case of thermocouple measurements).

Temperature measurement

Temperature transmitters

Compact and head transmitters

SITRANS TH200 (4 to 20 mA, universal)

Selection and ordering data

	Article No.
Head transmitter SITRANS TH200 For installation in connection head type B, 2-wire system 4 ... 20 mA, programmable, with galvanic isolation	
Without explosion protection	7NG3211-1NN00
With explosion protection	
• According to ATEX	7NG3211-1AN00
• According to FM (cFM _{US})	7NG3211-1BN00
Options	Order code
Append suffix "-Z" to article no., add order code and plain text, if applicable.	
Test report (5 measuring points)	C11
Functional safety SIL2	C20
Functional safety SIL2/3	C23
Customer-specific programming	
Measuring range to be set	Y01¹⁾
Specify in plain text (max. 5 digits): Y01:... to ... °C, °F	
Measuring point number (TAG) max. 8 characters	Y17²⁾
Measuring point description, max. 16 characters	Y23²⁾
Measuring point message, max. 32 characters	Y24²⁾
Pt100 (IEC) 2-wire, R _L = 0 Ω	U02³⁾
Pt100 (IEC) 3-wire	U03³⁾
Pt100 (IEC) 4-wire	U04³⁾
Type B thermocouple	U20³⁾⁴⁾
Type C thermocouple (W5)	U21³⁾⁴⁾
Type D thermocouple (W3)	U22³⁾⁴⁾
Type E thermocouple	U23³⁾⁴⁾
Type J thermocouple	U24³⁾⁴⁾
Type K thermocouple	U25³⁾⁴⁾
Type L thermocouple	U26³⁾⁴⁾
Type N thermocouple	U27³⁾⁴⁾
Type R thermocouple	U28³⁾⁴⁾
Type S thermocouple	U29³⁾⁴⁾
Type T thermocouple	U30³⁾⁴⁾
Type U thermocouple	U31³⁾⁴⁾
For TC: Cold junction compensation: external (Pt100, 3-wire)	U41
For TC: Cold junction compensation: external with fixed value: specify in plain text	Y50
Enter special deviating customer-specific setting in plain text	Y09⁵⁾
Fault current 3.6 mA (instead of 22.8 mA)	U36²⁾
Cable extension Transmitter with installed cable extension 200 mm (7.87 inch), for Pt100 in 4-wire connection	W01

- 1) For customer-specific programming for RTD and TC, the start value and the end value of the required measuring span must be specified here.
- 2) For this selection, Y01 or Y09 must also be selected.
- 3) For this selection, Y01 must also be selected.
- 4) Internal reference junction compensation is selected as the default for TC.
- 5) For customer-specific programming for mV and ohm, the start value and the end value of the required measuring span and the unit must be entered here.

Accessories

	Article No.
Additional accessories for assembly, connection and transmitter configuration, see page 2/251.	
Modem Modem with USB interface and SIPROM T software	7NG3092-8KN
Mounting rail adapter for head transmitter (Quantity delivered: 5 units)	7NG3092-8KA
Connecting cable 4-wire, 200 mm (7.87 inch), for sensor connections when using head transmitters in the high hinged cover (set with 5 units)	7NG3092-8KC

For supply units, see Catalog FI01 section "Supplementary components"

Ordering example 1:

7NG3211-1NN00-Z Y01+Y17+U03

Y01: -10 ... +100 °C

Y17: TICA123

Ordering example 2:

7NG3211-1NN00-Z Y01+Y23+ U25

Y01: -10 ... +100 °C

Y23: TICA1234HEAT

Factory setting:

- Pt100 (IEC 751); 3-wire connection
- Measuring range: 0 ... 100 °C (32 ... 212 °F)
- Fault current: 22.8 mA
- Sensor offset: 0 °C (0 °F)
- Damping 0.0 s

Dimensional drawings

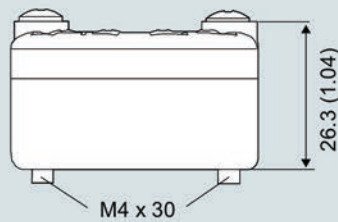
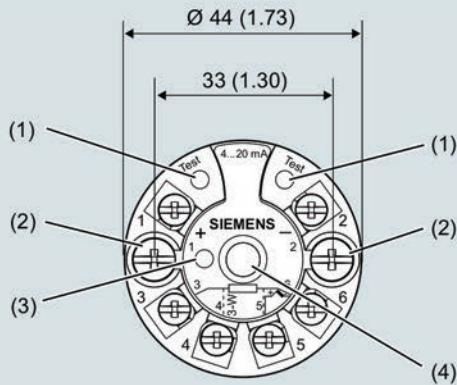

- 1(+) and 2(-) Auxiliary power supply U_{aux} , output current I_{out}
- 3, 4, 5 and 6 Pt100 sensor (for connections, see sensor connection assignment)
- Test (+), Test (-) Measurement of the output current with a multimeter
- (1) Test terminal
- (2) Mounting screw M4x30
- (3) LED for operation indication
- (4) Internal diameter of center hole 6.3 (0.25)

SITRANS TH200, dimensions and pin assignment, dimensions in mm (inch)

Mounting on DIN rail

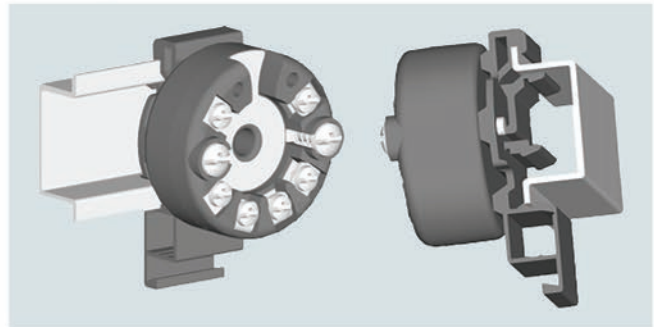

SITRANS TH200, mounting of transmitter on DIN rail

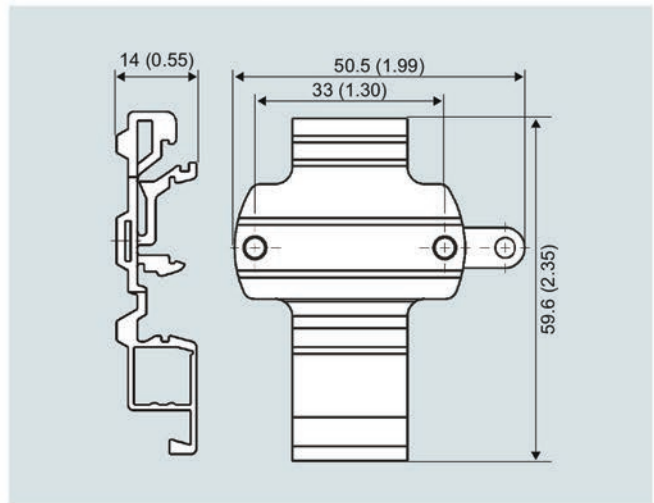

DIN rail adapter, dimensions in mm (inch)

Temperature measurement

Temperature transmitters

Compact and head transmitters

SITRANS TH200 (4 to 20 mA, universal)

Circuit diagrams

2

Resistance thermometer

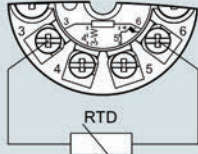

2-wire connection ¹⁾

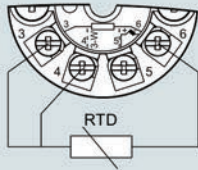

3-wire connection

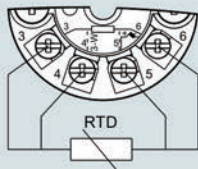

4-wire connection

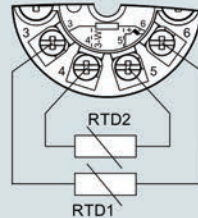

Generation of average value / difference ¹⁾

¹⁾ Programmable line resistance for the purpose of correction.

Resistance

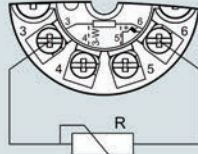

2-wire connection ¹⁾

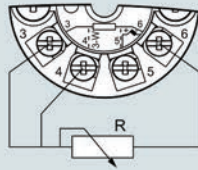

3-wire connection

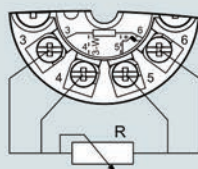

4-wire connection

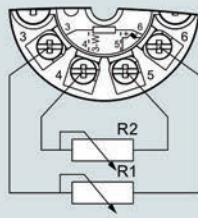

Generation of average value / difference ¹⁾

Thermocouple

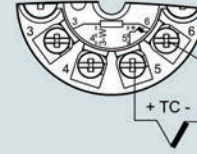

Cold junction compensation
Internal/external fixed value

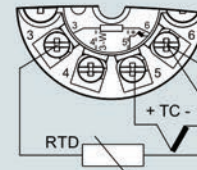

Cold junction compensation with external Pt100 in 2-wire connection ¹⁾

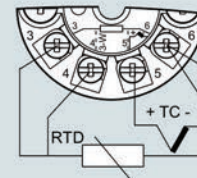

Cold junction compensation with external Pt100 in 3-wire connection

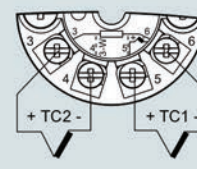

Generation of average value / difference with internal cold junction compensation

Voltage measurement

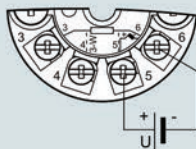

Current measurement

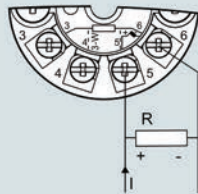

Connection of auxiliary power supply (U_{aux})

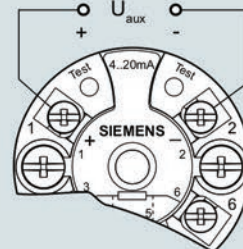

SITRANS TH200, sensor connection assignment