

## Temperature Measurement

Temperature sensors  
SITRANS TSthermowell

Thermowells according to DIN 43772

### Dimensional drawings

#### Thermowells according to DIN 43772 - Form 4

7MT14, welded

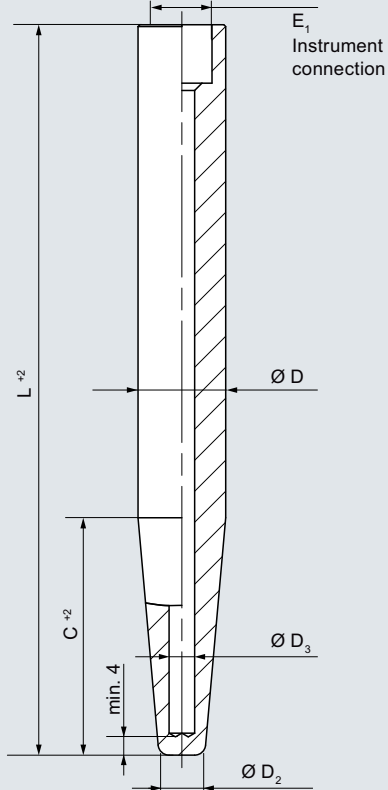

7MT14, flange connection

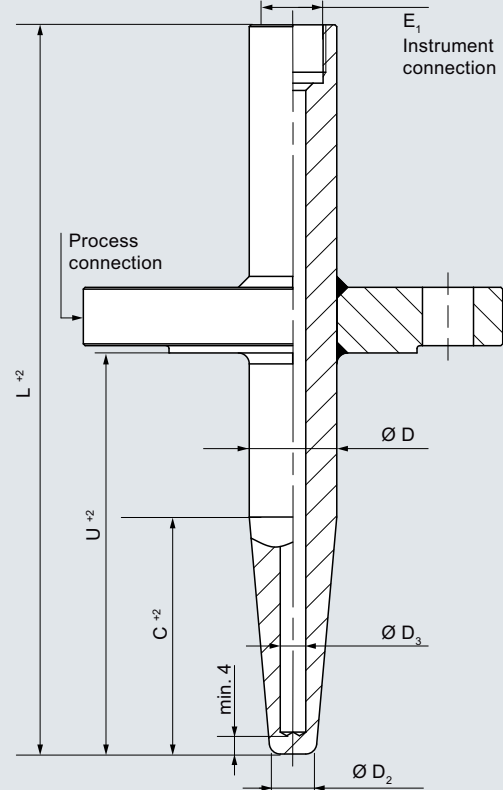

Since March 2000, DIN 43772 replaces the retracted DIN 43763: 1986-03

The name of the D sleeves is from the previous standard but still used today. The table below shows the order information for the corresponding successor products from DIN 43772.

Design	L [mm]	C [mm]	Ordering data
D1	140	65	<b>7MT1410-2*N00-0NQ2</b>
D2	200	125	<b>7MT1410-4*N00-0NQ4</b>
D4	200	65	<b>7MT1410-4*N00-0NQ2</b>
D5	260	125	<b>7MT1410-5*N00-0NQ4</b>

Material:

\* = **A**: 1.4571

\* = **B**: 1.4404

\* = **S**: 1.7335

\* = **T**: 1.5415

Selection and Ordering data			Article No.	Order code
<b>Barstock thermowells according to DIN 43772 - Form 4</b>			7 MT	
<a href="#">Click on the Article No. for the online configuration and configuration check in the PIA Life Cycle Portal.</a>				
<b>Basic model</b>				
<b>Standard</b>	<b>Process connection</b>	<b>Form</b>		
DIN	Weld-in/flange connection	Form 4/4F	1 4	
<b>External diameter of root D</b>	<b>External diameter of tip D2</b>	<b>Bore hole D3</b>		
24 mm	12.5 mm	7 mm	1	
26 mm	12.5 mm	7 mm	2	
32 mm	17 mm	11 mm	3	
<b>Thermowell length L</b>				
110 mm			0 1	
140 mm			0 2	
170 mm			0 3	
200 mm			0 4	
260 mm			0 5	
410 mm			0 6	
<b>Thermowell material</b>				
316Ti / 1.4571				
316L / 1.4404				
Hastelloy C276 / 2.4819				
1.7335 Heat-resistant				
1.5415 Heat-resistant				
PTFE coating (thermowell made of 316/TI/L)				
ECTFE (HALAR) (thermowell made of 316/TI/L)				
Stellite coating (thermowell made of 316/TI/L)				
Customer-specific thermowell			9 8	8 N
				Y 9 9
				+
				Y 4 6
<b>Process connection material</b>				
Without (Form 4 for welding)				
316Ti / 1.4571				
316L / 1.4404				
Hastelloy C276 / 2.4819 (flange with flanged wheel)				
1.7335 Heat-resistant				
1.5415 Heat-resistant				
PTFE coating (thermowell made of 316/TI/L)				
ECTFE (HALAR) (thermowell made of 316/TI/L)				
Stellite coating (thermowell made of 316/TI/L)				
<b>Process connection</b>				
Without (Form 4 for welding)				
Flange according DIN EN 1092-1 Sealing surface Initial: B1 for uncoated variants				
• DN 40, PN 10 - 16				
• DN 40, PN 25 - 40				
• DN 50, PN 10 - 16				
• DN 50, PN 25 - 40				
Flansch according ASME B16.5 Sealing surface Initial: RF for uncoated variants				
• 1.50 inch; Class 150				
• 1.50 inch; Class 300				
• 1.50 inch; Class 600				
• 2.00 inch; Class 150				
• 2.00 inch; Class 300				
• 2.00 inch; Class 600				
Customer-specific process connection			Z 8 8	K 1 Y
<b>Installation length U</b>				
For welding (no process connection)				
130 mm				0 N
190 mm				0 A
340 mm				0 B
				0 C
Customer-specific installation length			8 Y	Y 4 4

## Temperature Measurement

Temperature sensors  
SITRANS TSthermowell

### Thermowells according to DIN 43772

Selection and Ordering data	Article No.	Order code
<b>Barstock thermowells according to DIN 43772 - Form 4</b>	7 MT	
<b>Connection to thermometer E1 (female thread)</b>		Q R T U W X Z
M18x1.5		
M20x1.5		
M27x2.0		
½-14 NPT		
G½		
G¾		
Special version		Q 1 Y
<b>Cone length C</b>		
Without (straight)		0
65 mm		2
73 mm		3
125 mm		4
133 mm		5
275 mm		6

Selection and Ordering data	Order code
<b>Options</b>	
Add "-Z" to Article No. and add options, separate extensions with "+".	
<b>Acceptance test certificate according to EN 10204-3.1</b>	
Material certificate for wetted parts	C12
PMI (positive material ident.) for wetted parts	C15
Pressure test	C31
Helium leak test	C32
Dye-penetration-test	C33
Visual, dimensional and functional check	C34
Compliance with order	C35
X-ray test concentricity of bore hole	C47
Ultrasound test concentricity of bore hole	C48
MR-01-75 NACE conformity	C50
MR-01-03 NACE conformity	C53
Grease-free (cleaned for oxygen applications, for example)	C51
<b>Additional options</b>	
Thread protection stainless steel plug and chain	A55
Forged flange	A76
Sealing surface with concentric lines	A77
TAG-marking	Y15

Selection and Ordering data	Order code
<b>Surface treatment, options on request</b>	
Wetted parts stained, neutralized and passivated	W01
Wetted parts electropolished	W02
<b>Additional flange sealing surfaces</b>	
FF-Flat Face according to ASME B16.5	A70
RTJ-Ring-Type Joint according to ASME B16.5	A71
Type B2 according to EN1092-1	A72
Type C according to EN1092-1	A73
Type D according to EN1092-1	A74
<b>Additional information</b>	
Add "-Z" to Article No. and specify Order code.	
Additional information in plain text: Process connection (material, type)	K1Y
Additional information in plain text: Connection to thermometer E1	Q1Y
<b>Customer specific production</b>	
Processing and quotation number of special version: specify in plain text	Y99

Dimensional drawings

Thermowells according to ASME B 40.9

7MT21, screwed design, straight, tapered process connection	7MT21, screwed design, cylindrical process connection	7MT31, for welding, straight
7MT22, screwed design, reduced, tapered process connection	7MT22, screwed design, reduced, cylindrical process connection	7MT32, for welding, reduced
7MT23, screwed design, tapered, tapered process connection	7MT23, screwed design, tapered, cylindrical process connection	7MT33, for welding, tapered

# Temperature Measurement

Temperature sensors  
SITRANS TSthermowells

## Thermowells according to ASME B40.9

2

**7MT41, flange connection, straight**

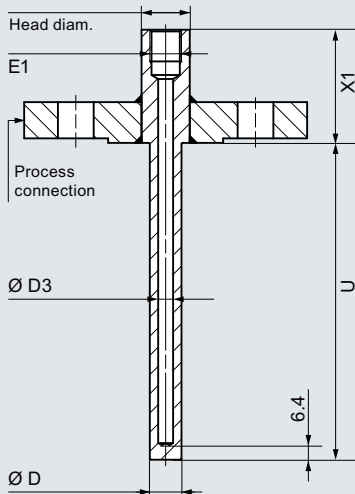

**7MT51, Van Stone type, straight**

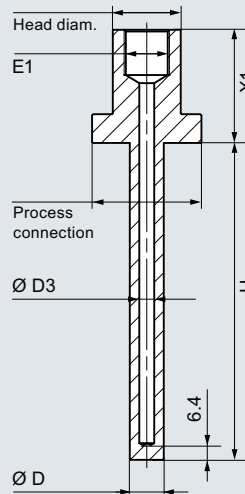

**7MT42, flange connection, reduced**

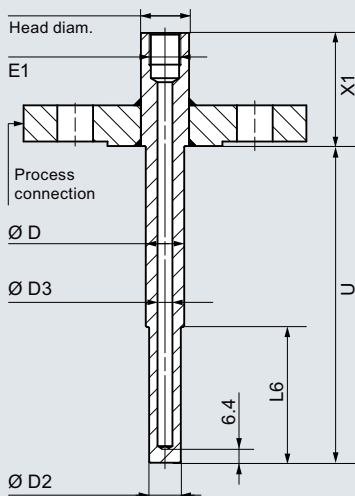

**7MT52, Van Stone type, reduced**

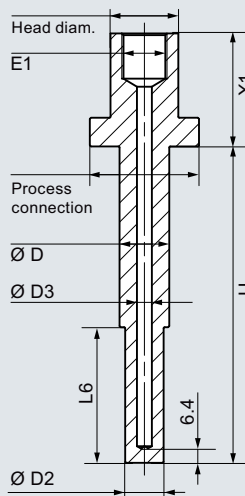

**7MT43, flange connection, tapered**

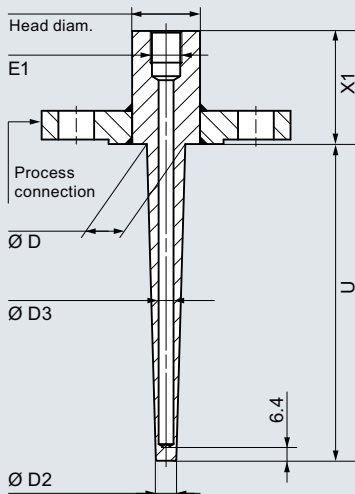

**7MT53 Van Stone type, tapered**

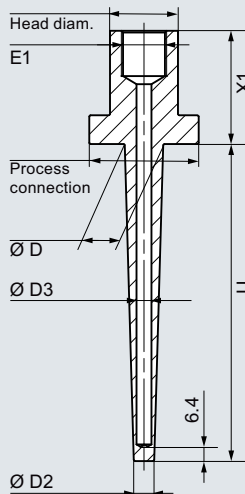

Selection and Ordering data				Article No.	Order code
<b>Barstock thermowells according to ASME 40.9</b>				7 MT	
<a href="#">Click on the Article No. for the online configuration and configuration check in the PIA Life Cycle Portal.</a>					
<b>Basic model</b>					
Standard	Process connection	Form			
ASME	Screwed design	Straight		2 1	
ASME	For welding	Straight		3 1	
ASME	Flange connection	Straight		4 1	
ASME	Van Stone type	Straight		5 1	
ASME	Screwed design	Reduced		2 2	
ASME	For welding	Reduced		3 2	
ASME	Flange connection	Reduced		4 2	
ASME	Van Stone type	Reduced		5 2	
ASME	Screwed design	Tapered		2 3	
ASME	For welding	Tapered		3 3	
ASME	Flange connection	Tapered		4 3	
ASME	Van Stone type	Tapered		5 3	
<b>Connection to thermometer E1</b>					
M18x1.5				1	
M20x1.5				2	
½-14 NPT				5	
G½				7	
Special version				9	Y 9 9
<b>Head diameter of the thermowell</b>					
Screwed design - width across flats	For welding	Flange connection	Van Stone head/ process connection		
H27	26.7 mm 33.4 mm 48.3 mm	28.6 mm 30 mm	33.4 mm / 51 mm 48.3 mm / 73 mm	0 1 2	
H32		32 mm	60.3 mm / 92 mm	3	
H36		34 mm		4	
H42		38 mm		5	
<b>Head length X1</b>					
	Screw-in	Weld-in	Flange	Van Stone	
25 ... 50 mm: Initial 38 mm (7MT2), 45 mm (7MT3/4)	✓	✓	✓		0
51 ... 75 mm: Initial 64 mm	✓	✓	✓	✓	1
76 ... 101 mm: Initial 89 mm	✓	✓	✓	✓	2
102 ... 126 mm: Initial 114 mm	✓	✓	✓	✓	3
127 ... 151 mm: Initial 140 mm	✓	✓	✓	✓	4
152 ... 177 mm: Initial 165 mm	✓	✓	✓	✓	5
178 ... 202 mm: Initial 191 mm	✓	✓	✓		6
<b>Installation length U</b>					
25 ... 126 mm: Initial 25 mm				A	
127 ... 253 mm: Initial 127 mm				B	
254 ... 380 mm: Initial 254 mm				C	
381 ... 507 mm: Initial 381 mm				D	
508 ... 634 mm: Initial 508 mm				E	
635 ... 761 mm: Initial 635 mm				F	
762 ... 888 mm: Initial 762 mm				G	

# Temperature Measurement

Temperature sensors  
SITRANS TSthermowells

## Thermowells according to ASME B40.9

### Selection and Ordering data

Article No.

Order code

### Barstock thermowells according to ASME 40.9

7 MT - - - - -

### Thermowell material

	Screw-in	Weld-in	Flange	Van Stone
316L / 1.4404	✓	✓	✓	✓
Carbon steel / A105	✓	✓	✓	✓
Hastelloy C276 / 2.4819 (flange with flanged wheel)			✓	✓
Hastelloy C22 / 2.4602 (flange with flanged wheel)			✓	✓
304L / 1.4306	✓	✓	✓	✓
321 / 1.4541	✓	✓	✓	✓
Monel alloy 400 / 2.4360 (flange with flanged wheel)			✓	✓
Tantalum (sleeve, thermowell, made of 316/Ti/L)			✓	✓
Duplex / 1.4462			✓	✓
Super Duplex / 1.4410			✓	✓
PTFE coating (thermowell made of 316/Ti/L)			✓	✓
ECTFE (HALAR) (thermowell made of 316/Ti/L)			✓	✓
Stellite coating (thermowell made of 316/Ti/L)			✓	✓
Customer-specific thermowell (head diameter/X1/U/material)	✓		✓	✓

### External diameter of root D/tip D2

#### Straight thermowell form

#### Reduced thermowell form

#### Tapered thermowell form

D	D	D2 (L6 = 60.3 mm/ 2.374 in)	D	D2
0.50 in (12.7 mm)				
0.625 in (15.9 mm)	0.625 in (15.9 mm)	0.5 in (12.7 mm)	0.625 in (15.9 mm)	0.5 in (12.7 mm)
0.75 in (19.1 mm)	0.75 in (19.1 mm)	0.5 in (12.7 mm)	0.75 in (19.1 mm)	0.5 in (12.7 mm)
1.00 in (25.4 mm)	1.00 in (25.4 mm)	0.5 in (12.7 mm)	1.00 in (25.4 mm)	0.50 in (12.7 mm)
1.25 in (31.8 mm)	1.25 in (31.8 mm)	0.5 in (12.7 mm)	1.00 in (25.4 mm)	0.50 in (12.7 mm)
1.50 in (38.1 mm)	1.50 in (38.1 mm)	0.5 in (12.7 mm)	1.00 in (25.4 mm)	0.75 in (19.1 mm)
			1.25 in (31.8 mm)	0.50 in (12.7 mm)
			1.25 in (31.8 mm)	0.75 in (19.1 mm)
			1.25 in (31.8 mm)	1.00 in (25.4 mm)
D = 12 mm (0.47 in)				
D = 14 mm (0.55 in)				
D = 16 mm (0.63 in)			1.50 in (38.1 mm)	0.50 in (12.7 mm)
D = 19 mm (0.75 in)			1.50 in (38.1 mm)	0.75 in (19.1 mm)
D = 22 mm (0.87 in)			1.50 in (38.1 mm)	1.00 in (25.4 mm)
D = 25 mm (0.98 in)			1.50 in (38.1 mm)	1.25 in (31.8 mm)
D = 27 mm (1.06 in)				
			12 mm (0.47 in)	9 mm (0.35 in)
			14 mm (0.55 in)	9 mm (0.35 in)
			16 mm (0.63 in)	9 mm (0.35 in)
			16 mm (0.63 in)	13 mm (0.51 in)
			16 mm (0.63 in)	14 mm (0.55 in)
			19 mm (0.75 in)	9 mm (0.35 in)
			19 mm (0.75 in)	13 mm (0.51 in)
			19 mm (0.75 in)	14 mm (0.55 in)
			22 mm (0.87 in)	9 mm (0.35 in)
			22 mm (0.87 in)	13 mm (0.51 in)
			22 mm (0.87 in)	14 mm (0.55 in)
			22 mm (0.87 in)	16 mm (0.63 in)
			25 mm (0.98 in)	9 mm (0.35 in)
			25 mm (0.98 in)	13 mm (0.51 in)
			25 mm (0.98 in)	14 mm (0.55 in)
			25 mm (0.98 in)	16 mm (0.63 in)
			25 mm (0.98 in)	19 mm (0.75 in)
			27 mm (1.06 in)	9 mm (0.35 in)
			27 mm (1.06 in)	13 mm (0.51 in)
			27 mm (1.06 in)	14 mm (0.55 in)
			27 mm (1.06 in)	16 mm (0.63 in)
			27 mm (1.06 in)	19 mm (0.75 in)
			27 mm (1.06 in)	22 mm (0.87 in)
			32 mm (1.26 in)	9 mm (0.35 in)
			32 mm (1.26 in)	13 mm (0.51 in)

B  
C  
E  
F  
H  
K  
L  
Q  
P  
R  
U  
V  
W  
9 8 NN G 1 Y

2

Selection and Ordering data			Article No.		Order code	
<b>Barstock thermowells according to ASME 40.9</b>			7 MT			
<b>External diameter of root D/tip D2 (continued)</b>						
<b>Straight thermowell form</b>		<b>Reduced thermowell form</b>		<b>Tapered thermowell form</b>		
<b>D</b>	<b>D</b>	<b>D2</b>	<b>D</b>	<b>D2</b>		
			32 mm (1.26 in)	14 mm (0.55 in)	7 2	
			32 mm (1.26 in)	16 mm (0.63 in)	7 3	
			32 mm (1.26 in)	19 mm (0.75 in)	7 4	
			32 mm (1.26 in)	22 mm (0.87 in)	7 5	
			32 mm (1.26 in)	25 mm (0.98 in)	7 6	
			34 mm (1.34 in)	9 mm (0.35 in)	8 0	
			34 mm (1.34 in)	13 mm (0.51 in)	8 1	
			34 mm (1.34 in)	14 mm (0.55 in)	8 2	
			34 mm (1.34 in)	16 mm (0.63 in)	8 3	
			34 mm (1.34 in)	19 mm (0.75 in)	8 4	
			34 mm (1.34 in)	22 mm (0.87 in)	8 5	
			34 mm (1.34 in)	25 mm (0.98 in)	8 6	
Customer-specific	Customer-specific		Customer-specific		9 0	L 1 Y
<b>Process connection</b>						
Thread for 7MT2... (Screw-in thermowells)						
<ul style="list-style-type: none"> <li>• G<math>\frac{1}{2}</math>"</li> <li>• G<math>\frac{3}{4}</math>"</li> <li>• G1"</li> <li>• R<math>\frac{1}{2}</math>"</li> <li>• R<math>\frac{3}{4}</math>"</li> <li>• R1"</li> <li>• <math>\frac{1}{2}</math>" NPT</li> <li>• <math>\frac{3}{4}</math>" NPT</li> <li>• 1" NPT</li> <li>• M20 x 1.5</li> <li>• M27 x 2</li> <li>• M33 x 2</li> </ul>					1 A 1 B 1 C 1 D 1 E 1 F 1 G 1 H 1 J 1 L 1 M 1 N	
Flange according to EN 1092-1 for 7MT4... (Flange thermowells), Sealing surface Initial: B1 for uncoated variants						
<ul style="list-style-type: none"> <li>• DN 25, PN 10 - 16</li> <li>• DN 40, PN 10 - 16</li> <li>• DN 50, PN 10 - 16</li> <li>• DN 50, PN 25 - 40</li> </ul>					2 D 2 F 2 H 2 J	
Flange according to ASME B16.5 for 7MT4... (Flange thermowells), Sealing surface Initial: RF for uncoated variants						
<ul style="list-style-type: none"> <li>• 1.00 inch; Class 150</li> <li>• 1.00 inch; Class 300</li> <li>• 1.00 inch; Class 600</li> <li>• 1.50 inch; Class 150</li> <li>• 1.50 inch; Class 300</li> <li>• 1.50 inch; Class 600</li> <li>• 2.00 inch; Class 150</li> <li>• 2.00 inch; Class 300</li> <li>• 2.00 inch; Class 600</li> <li>• 3.00 inch; Class 150</li> <li>• 3.00 inch; Class 300</li> <li>• 3.00 inch; Class 600</li> <li>• 4.00 inch; Class 150</li> <li>• 4.00 inch; Class 300</li> <li>• 4.00 inch; Class 600</li> </ul>					3 E 3 F 3 G 3 K 3 L 3 M 3 R 3 S 3 T 4 C 4 D 4 E 4 G 4 H 4 J	
For 7MT3... and 7MT5... (Weld-in and Van Stone thermowells)						
<ul style="list-style-type: none"> <li>• Without (optional collar flange for Van-Stone see "Options")</li> </ul>					0 N	



## Temperature Measurement

Temperature sensors  
SITRANS TSthermowells

### Thermowells according to ASME B40.9

Selection and Ordering data					Article No.	Order code
<b>Barstock thermowells according to ASME 40.9</b>					7 MT	
<b>Process connection material (identical to thermowell)</b>						
	Screw-in	Weld-in	Flange	Van Stone		
316L / 1.4404	✓		✓	✓		B
Carbon steel / A105	✓		✓			C
Hastelloy C276 / 2.4819 (Flange with flanged wheel)			✓			E
Hastelloy C22 / 2.4602			✓			F
304L / 1.4306	✓		✓			H
321 / 1.4541	✓		✓			K
Monel alloy 400 / 2.4360 (Flange with flanged wheel)			✓			L
Tantal (sleeve, thermowell made of 316/TI/L)			✓			Q
Duplex / 1.4462			✓			P
Super Duplex			✓			R
PTFE coating (thermowell made of 316/TI/L)			✓			U
ECTFE (HALAR) (thermowell made of 316/TI/L)			✓			V
Stellite coating (thermowell made of 316/TI/L)			✓			W
Customer-specific	✓		✓	✓		9NN
<b>Bore D3</b>						
D3 = 6.6 mm (0.260 in)						2
Customer-specific						9 R 1 Y

Auswahl- und Bestelldaten	Kurzangabe
<b>Options</b>	
Add "-Z" to Article No. and add options, separate extensions with "+".	
<b>Acceptance test certificate according to EN 10204-3.1</b>	
Material certificate for wetted parts	C12
PMI (positive material ident.) for wetted parts	C15
Pressure test	C31
Helium leak test	C32
Dye-penetration-test	C33
Visual, dimensional and functional check	C34
Compliance with order	C35
X-ray test for welding seams	C41
Ultrasound test for welding seams	C44
X-ray test concentricity of bore hole	C47
Ultrasound test concentricity of bore hole	C48
MR-01-75 NACE conformity	C50
MR-01-03 NACE conformity	C53
Grease-free (cleaned for oxygen applications, for example)	C51
<b>Additional options</b>	
Thread protection stainless steel plug and chain	A55
Forged flange	A76
Sealing surface with concentric lines	A77
TAG-marking	Y15
<b>Full penetration options</b>	
Process connection welded	G02
<b>Surface treatment, options on request</b>	
Wetted parts stained, neutralized and passivated	W01
Wetted parts electropolished	W02

Auswahl- und Bestelldaten	Kurzangabe
<b>Additional flange sealing surfaces</b>	
FF-Flat Face according to ASME B16.5	A70
RTJ-Ring-Type Joint according to ASME B16.5	A71
Type B2 according to EN1092-1	A72
Type C according to EN1092-1	A73
Type D according to EN1092-1	A74
<b>Additional information</b>	
Add "-Z" to Article No. and specify Order code.	
Additional information in plain text: Thermowell (head diameter/X1/U/material)	G1Y
Additional information in plain text: AD root D / [tip D2]	L1Y
Additional information in plain text: Process connection (material/type):	N1Y
Additional information in plain text: Bore hole D3:	R1Y
<b>Customer specific production</b>	
Length options U: Specify special installation length (in spec. area)	Y44
Length options X1: Specify special length extension (in spec. area)	Y45
Processing and quotation number of special version: specify in plain text	Y99
<b>Optional collar flanges 316L (Van Stone only)</b>	
1.00 inch, Class 150 sealing surface initial: RF	B24
1.00 inch, Class 300 sealing surface initial: RF	B25
1.00 inch, Class 600 sealing surface initial: RF	B26
1.50 inch, Class 150 sealing surface initial: RF	B29
1.50 inch, Class 300 sealing surface initial: RF	B30
1.50 inch, Class 600 sealing surface initial: RF	B31
2.00 inch, Class 150 sealing surface initial: RF	B35
2.00 inch, Class 300 sealing surface initial: RF	B36
2.00 inch, Class 600 sealing surface initial: RF	B37