

## Temperature Measurement

Temperature sensors  
SITRANS TS200

Compact version, mineral-insulated

### Dimensional drawings

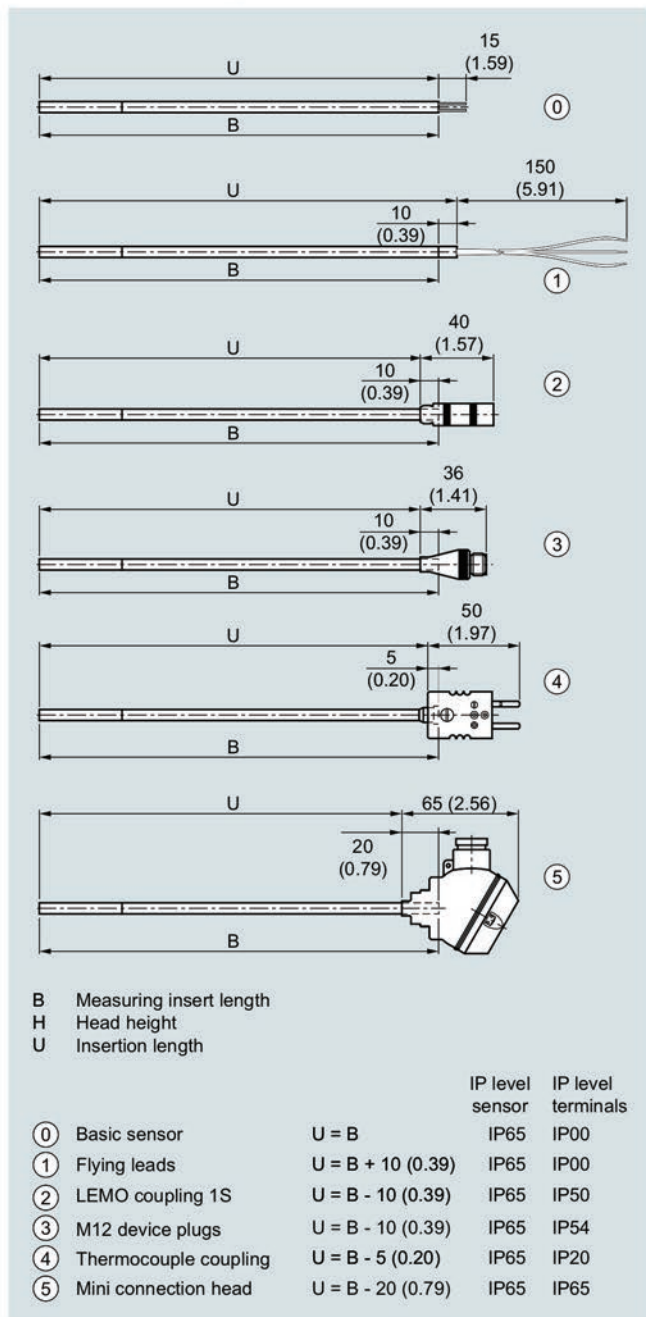

SITRANS TS200, temperature sensors in cable design, for universal use, mineral-insulated version, for unfavorable space conditions, dimensions in mm (inch)

Selection and Ordering data	Article No.	Selection and Ordering data	Order code
<b>SITRANS TS200</b> Temperature sensors in compact version, universal use, mineral-insulated version, for unfavorable space conditions ↗ Click on the Article No. for the online configuration in the PIA Life Cycle Portal.	↗ <b>7MC7212-</b> 	<b>Further designs</b> Add "-Z" to Article No. and specify Order code.	
<b>Sensor diameter</b> 6 mm (0.24 inch)	6	<b>Customer-specific length of sensor element B, effective length, U see dimensional drawing on page 2/44</b> Select range, enter desired length in plain text (No entry = standard length)	Y44
<b>Length of sensor element B, effective length U see dimensional drawing on page 2/44</b> 200 mm (7.87 inch) 500 mm (19.68 inch) 750 mm (29.53 inch)	C D E	1) Pt1000 versions are also available. To find these, please switch to Online Configuration in the PIA Life Cycle Portal: <a href="http://www.siemens.com/pia-portal">www.siemens.com/pia-portal</a>	
<b>Customer-specific length of sensor element B, effective length U see dimensional drawing on page 2/44</b> enter customer specific length with Y44, see Order codes below 70 ... 100 mm (2.76 ... 3.94 inch) Initial: 100 mm (3.94 inch) 101 ... 250 mm (3.98 ... 9.84 inch) Initial: 200 mm (7.87 inch) 251 ... 500 mm (9.88 ... 19.68 inch) Initial: 500 mm (19.68 inch) 501 ... 750 mm (19.72 ... 29.53 inch) Initial: 750 mm (29.53 inch) 751 ... 1 000 mm (29.57 ... 39.37 inch) Initial: 1 000 mm (39.37 inch) 1 001 ... 1 500 mm (39.4 ... 59.00 inch) Initial: 1 500 mm (59.00 inch) Special length: < 70 mm (2.76 inch) or > 1500 mm (59.00 inch)	B C D E F G X	<b>Additional configurations on page after next page!</b> <b>You find ordering examples on page 2/40.</b>	
<b>Sensor<sup>1)</sup></b> Please note: The accuracy class range can be lower than the measuring range. For more information, see page 2/21 Pt100, basis, -50 ... +400 °C (-58 ... +752 °F) Pt100, vibration-resistant, -50 ... +400 °C (-58 ... +752 °F) Pt100, expanded range, -196 ... +600 °C (-320.8 ... +1 112 °F) Thermocouple Type K, -40 ... +1 000 °C (-40 ... +1 832 °F) Thermocouple Type J, -40 ... +750 °C (-40 ... +1 382 °F)	A B C K J		
<b>Number/Accuracy</b> Pt 100 connection: 1 x 4-wire connection or 2 x 3-wire connection, see "Measuring technology: connection types", page 2/23 Single, basic accuracy (Class 2/Class B) Single, increased accuracy (Class 1/Class A) Single, highest accuracy (Class AA) Double, basic accuracy (Class 2/Class B) Double, increased accuracy (Class 1/Class A) Double, highest accuracy (Class AA)	1 2 3 4 5 6		
<b>Design of connection side</b> Solid wire ends (sensor element) Flying leads LEMO coupling 1S M12 device plug, not for double Pt100 Thermocouple coupling, from TC-material (2xTC on request) Mini connection head, aluminum, not for double Pt100	0 1 2 3 4 5		

## Temperature Measurement

Temperature sensors  
SITRANS TS200

### Compact version, mineral-insulated

2

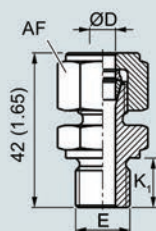

Compression fitting, metric (A30, A31), dimensions in mm (inch)

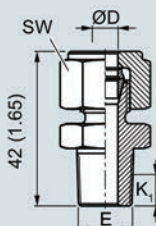

Compression fitting NPT (A32), dimensions in mm (inch)

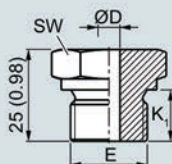

Soldering nipple, metric (A20, A21, A23), dimensions in mm (inch)

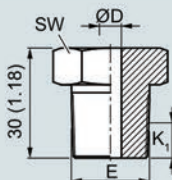

Soldering nipple NPT (A22), dimensions in mm (inch)

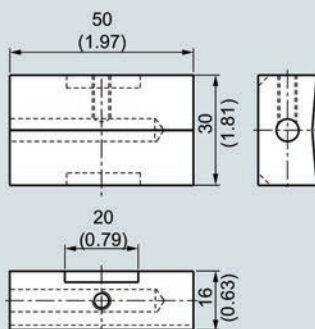

Surface connection piece (A50), dimensions in mm (inch)

### Selection and Ordering data

Order code

#### Options

Add **"-Z"** to Article No., add options, separate extensions with "+".

#### Process connection

Soldering nipple G $\frac{1}{4}$ ", enclosed	A20
Soldering nipple G $\frac{1}{2}$ ", enclosed	A21
Soldering nipple NPT $\frac{1}{2}$ ", enclosed	A22
Soldering nipple M18x1.5, enclosed	A23
Compression fitting G $\frac{1}{4}$ ", enclosed	A30
Compression fitting G $\frac{1}{2}$ ", enclosed	A31
Compression fitting NPT $\frac{1}{2}$ ", enclosed	A32
Surface connection piece, aluminum, enclosed (non Ex)	A50

#### Explosion protection

Without explosion protection requirements (Europe, Australia, New Zealand)	E00
Intrinsic safety "i"/IS1 according to ATEX and IECEx (Europe, Australia, New Zealand)	E01
Without explosion protection requirements (USA, Canada), Basis CSA	E17
Intrinsic safety "i"/IS*1 according to cCSAus (USA, Canada)	E18
Without explosion protection requirements (China)	E54
Intrinsic safety "i"/IS*1 according to NEPSI (China)	E55
Without explosion protection requirements (EAC)	E80
Intrinsic safety "i"/IS*1 according to EACEx (EAC)	E81

#### Marine approvals

Det Norske Veritas Germanischer Lloyd (DNV GL)	D01
--	-----

#### Certificates and approvals

EN 10204-3.1 Inspection certificate for materials coming into contact with media	C12
EN 10204-3.1 Inspection certificate visual, measurement and functional inspection	C34
EN 10204-2.1: Declaration of compliance with the order	C35
ISO 9001 grease-free (cleaned for e.g. oxygen applications)	C51

Setting, designation, calibration

Stainless steel TAG plate , Enter lettering in plain text	Y15
--	-----

Plant calibration per 1 point, enter temperature in plain text. Attention: For devices with built-in head transmitters, select test points within the set measurement range

#### Option not found?

Handling number special version	Y99
---------------------------------	-----

<sup>1)</sup> Please select Ex i version of the optional transmitter.

**You find ordering examples on page 2/40.  
Accessories, see page 2/251.**