

Overview

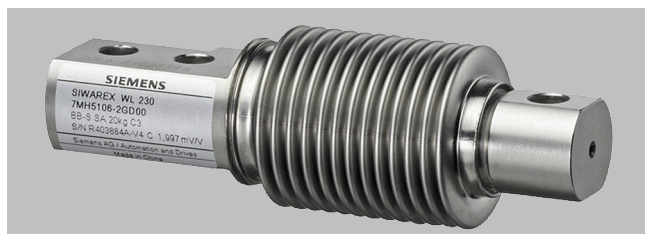

The bending beam load cell is particularly suitable for use in small hopper and platform scales.

Design

The measuring element is a double bending beam made of stainless steel to which 4 strain gauges are applied.

The strain gauges are arranged so that two are stretched and two are compressed.

Under the influence of the load acting in the measuring direction, the spring bodies and therefore the friction-locked strain gauges are elastically deformed. This generates a measuring signal voltage that is proportional to the load.

Selection and ordering data

Load cell, type WL230 BB-S SA Legal-for-trade according to OIML R60 up to 3 000d, connecting cable 3 m (9.84 ft)	Article No. 7MH5106-			
	●	●	D 0	●
Click on the Article No. for the online configuration in the PIA Life Cycle Portal.				
Rated load				
• 10 kg (22.05 lb)	2	A		
• 20 kg (44.09 lb)	2	G		
• 50 kg (110.23 lb)	2	P		
• 100 kg (220.46 lb)	3	A		
• 200 kg (440.92 lb)	3	G		
• 350 kg (771.62 lb)	3	L		
• 500 kg (1102.31 lb)	3	P		
Explosion protection				
Without				0
Explosion protection				1

Load Cells

Bending beam load cells

SIWAREX WL230 BB-S SA Load cell

Technical specifications

SIWAREX WL230 BB-S SA	
Possible applications	<ul style="list-style-type: none"> Hopper scales Belt scales Platform scales
Type of construction	Bending beam load cell
Loads	
Rated load E_{max}	<ul style="list-style-type: none"> 10 kg (22.05 lb) 20 kg (44.09 lb) 50 kg (110.23 lb) 100 kg (220.46 lb) 200 kg (440.92 lb) 350 kg (771.62 lb) 500 kg (1 102.3 lb)
Minimum initial loading E_{min}	0% E_{max}
Maximum working load L_u	150% E_{max}
Breaking load L_d	300% E_{max}
Safe side load L_{Lq}	100% E_{max}
Measurement characteristic values	
Rated displacement h_n at E_{max}	0.3 mm
Rated characteristic value C_n	$2.0 \pm 0.02\%$ mV/V
Tolerance D_0 of zero signal	$< \pm 1.0\%$ C_n
Maximum scale interval n_{LC}	3 000 ¹⁾
Minimum scale interval V_{min}	$E_{max}/15\ 000$
Minimum application range $R_{min(LC)}$	20%
Combined error F_{comb}	$\leq 0.02\%$ C_n
Repeatability F_v	$\leq 0.017\%$ C_n
Creep error F_{cr}	<ul style="list-style-type: none"> 30 min $\leq \pm 0.02\%$ C_n
Temperature coefficient	
• Zero signal T_{K0}	$\leq \pm 0.017\%$ $C_n/5\ K$
• Characteristic value T_{Kc}	$\leq \pm 0.014\%$ $C_n/5\ K$
Electrical characteristic values	
Recommended reference voltage U_{ref}	5 ... 10 V DC
Input resistance R_e	$460\ \Omega \pm 50\ \Omega$
Output resistance R_a	$350\ \Omega \pm 3.5\ \Omega$
Insulation resistance R_{is}	5 000 M Ω at 50 V DC
Current calibration	Standard
Connection and environmental conditions	
Sensor material (DIN)	Stainless steel EN 1.4542
Max. tightening torque of the fixing screws	
• $E_{max} = 10, 200\ kg (22.05 \dots 440.92\ lb)$	23 Nm ²⁾
• $E_{max} = 350, 500\ kg (771.62, 1\ 102.31\ lb)$	70 Nm ²⁾
Function	
	Color
• EXC + (supply +)	Green
• EXC - (supply -)	Black
• SIG + (measured signal +)	White
• SIG - (measured signal -)	Red
• Shield (not connected to the load cell body)	Transparent
Rated temperature range B_{Tn}	-10 ... +40 °C (+14 ... +104 °F)
Operating temperature range B_{Tu}	-35 ... +65 °C (-31 ... +149 °F)
Storage temperature range B_{Ts}	-35 ... +65 °C (-31 ... +149 °F)
Degree of protection according to EN 60529; IEC 60529	IP68
Certificates and approvals	
Accuracy class according to OIML R60	C3

Technical specifications (Continued)

SIWAREX WL230 BB-S SA	
Explosion protection	<ul style="list-style-type: none"> EU/UK: <ul style="list-style-type: none"> - ATEX/UKEX II 1 G Ex ia IIC T4 - ATEX/UKEX II 1 D Ex ia IIIC T200 135°C D-a - ATEX/UKEX II 3 G Ex ic IIC T4 Gc - ATEX/UKEX II 3 D Ex tc IIIC T73°C Dc - ATEX/UKEX II 3 G Ex ec T4 IIC Gc USA: <ul style="list-style-type: none"> - IS CL I, II, III, DIV 1, GP A, B, C, D, E, F, G; T4 - IS CL I, ZN 0, AEx ia IIC T4 Ga - Zone 20, AEx ia IIIC T135°C Da - CL I, II, III, DIV 2, GP A, B, C, D, E, F, G; T4 - CL 1, ZN 2, GP IIC T4 - IS CL I, ZN 2, AEx ic IIC T4 Gc Canada: <ul style="list-style-type: none"> - IS CL I, II, III, DIV 1, GP A, B, C, D, E, F, G; T4 - IS CL I, ZN 0, Ex ia IIC T4 Ga - Ex ia IIIC T135°C Da - CL I, II, III, DIV 2, GP A, B, C, D, E, F, G; T4 - CL 1, ZN 2, GP IIC T4 - Ex ic IIC T4 Gc China: <ul style="list-style-type: none"> - NEPSI Ex ia IIC T6 Ga; Ex iaD 20 T80

1) Higher accuracy class available on request.

2) The tightening torque is to be selected according to the strength class of the screws.

Dimensional drawings

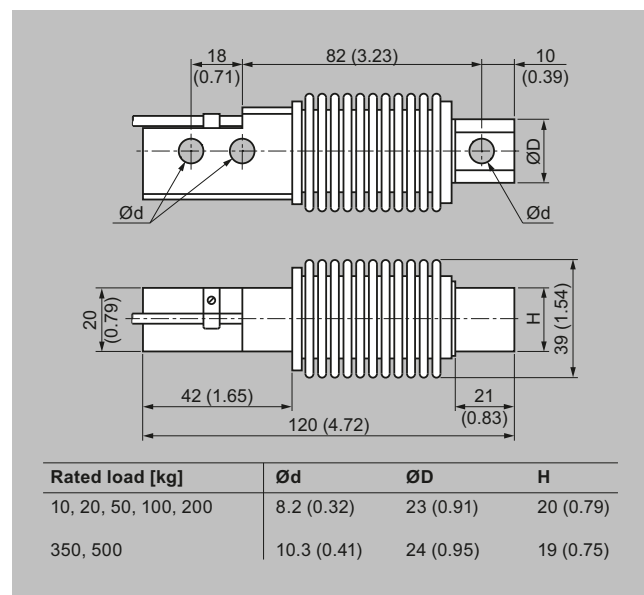

SIWAREX WL230 BB-S SA load cell, dimensions in mm (inch)

Overview

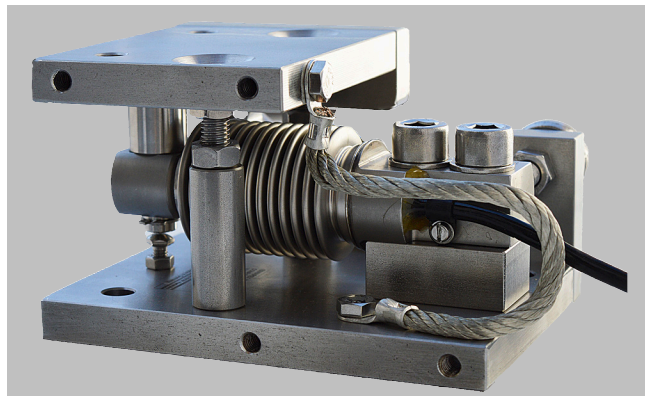

The self-centering installation unit for SIWAREX WL230 BB-S SA load cells is particularly suitable for implementation in small-scale container, platform and roller table scales.

Design

The mounting unit comprises a base plate and a top plate, a pendulum bolt, two countersunk screws and overload protection.

A highly flexible grounding cable between the top and base plate conducts any fault currents past the load cell. On both sides of the base and top plate there are threaded holes for the later flange-fitting of guide elements.

The top plate is aligned and fixed above the base plate with the two countersunk screws. This results in a stable unit. The height of the top plate can be adjusted so that it is two millimeters above the installation height with load cell.

In this state, the mounting unit serves as an installation aid and can be used as a dummy for light installation jobs.

The load cell is inserted with the pendulum bolt into the mounting unit. The load cell can be inserted in the scale before mounting the mounting unit. It is also possible to insert the load cell in the mounting unit after mounting. After the mounting unit has been mounted in the scale, the load bearing implement is ideally aligned. The load cells are not yet loaded.

Finally, the load bearing implement is lowered by loosening the two hexagon nuts under the top plate. The weight now rests on the load cells.

In this state the load cell and the pressure pieces together form a self-centering unit. The mounting unit permits sideways displacement of the top plate, and hence of the load bearing implement, by up to 2 mm (0.079 in). The countersunk head screws prevent the load bearing implement from being lifted off or tipping.

The overload protection is set so that the load cell cannot be loaded beyond the limit load.

Using the mounting unit as an installation aid results in optimum alignment of the load cells. This is essential to enable the load cells to perform at their best in terms of accuracy. For maintenance or troubleshooting purposes, the load cell can be relieved again by tightening the hexagon nuts. After loosening the clamping washers, it can then easily be replaced. Guide elements are used if the lateral movement of a load bearing implement is to be prevented. Lateral movements can be initiated by agitator start-up in a container, by braking or accelerating forces in a roller conveyor, or through forces exerted by the wind on outdoor silos. A guide element consists of two flanges and one clamping screw. The clamping screw is adjusted to the correct length. The guide element is attached to the operational mounting unit. A guide element can be mounted on the front or rear of the mounting unit. If necessary, two guide elements can be used in parallel in order to double the transferrable lateral force. In the case of scales with four load cells, only three mounting units may be equipped with guide elements. Shims are used to compensate for angular errors and delays in the lug plates. If more

Design (Continued)

than three load cells are used, the shims are also used to adjust the height of the lugs.

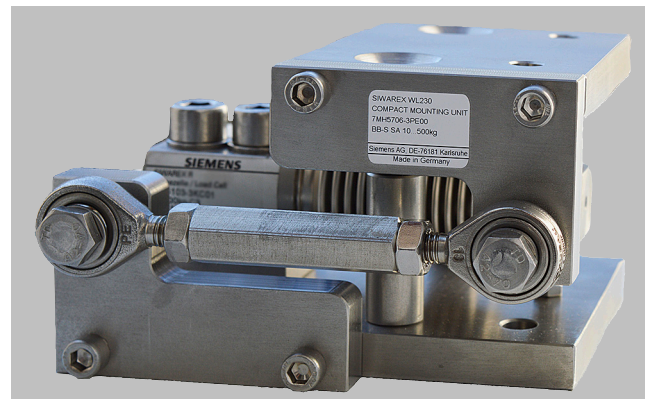

Guide element for SIWAREX WL230 BB-S SA mounting units

Selection and ordering data

	Article No.
Compact mounting units For load cells of the SIWAREX WL230 BB-S SA series Material: Stainless steel EN 1.4301 and EN 1.4112 For load cells with a rated load of <ul style="list-style-type: none"> • 10 ... 200 kg (22.05 ... 440.92 lb)¹⁾ • 350, 500 kg (771.61, 1 102.3 lb)¹⁾ 	7MH5706-3GA00 7MH5706-3PA00
Guide elements (optional) For load cells of the SIWAREX WL230 BB-S SA series Material: Stainless steel EN 1.4301 For load cells with a rated load of ¹⁾ <ul style="list-style-type: none"> 10 ... 500 kg (22.05 ... 1102.3 lb); permissible lateral force: 2.5 kN 	7MH5706-3PE00
Shims (accessories) For compact mounting units of the SIWAREX WL230 BB-S SA series Material: Stainless steel EN 1.4301 For load cells with a rated load of ¹⁾ <ul style="list-style-type: none"> • 10 ... 200 kg (22.05 ... 440.92 lb); Content: 16 units, each 0.5 mm thick 	7MH5713-3JG00

¹⁾ The load cell is not included in the scope of delivery.

Load Cells

Bending beam load cells

SIWAREX WL230 BB-S SA Mounting unit

Technical specifications

Mounting unit for load cells of the SIWAREX WL230 BB-S SA series

Rated load	10 ... 200 kg (22.01 ... 440.92 lb)	350, 500 kg (771.62, 1 102.31 lb)
Permissible lateral deflection:	± 2 mm (0.08 inch)	± 2 mm (0.08 inch)
Lifting path of top plate	2 ... 2.5 mm (0.08 ... 0.10 inch)	2 ... 2.5 mm (0.18 ... 0.10 inch)
Max. lateral force	1.7 kN	2.5 kN
Max. lifting force	2.5 kN	2.5 kN

Stainless steel guide element

Size	Values with rated load
	10 ... 500 kg (22.01 ... 1 102.31 lb)
Permissible lateral force ¹⁾	2.5 kN

¹⁾ The values apply to one guide element.

Dimensional drawings

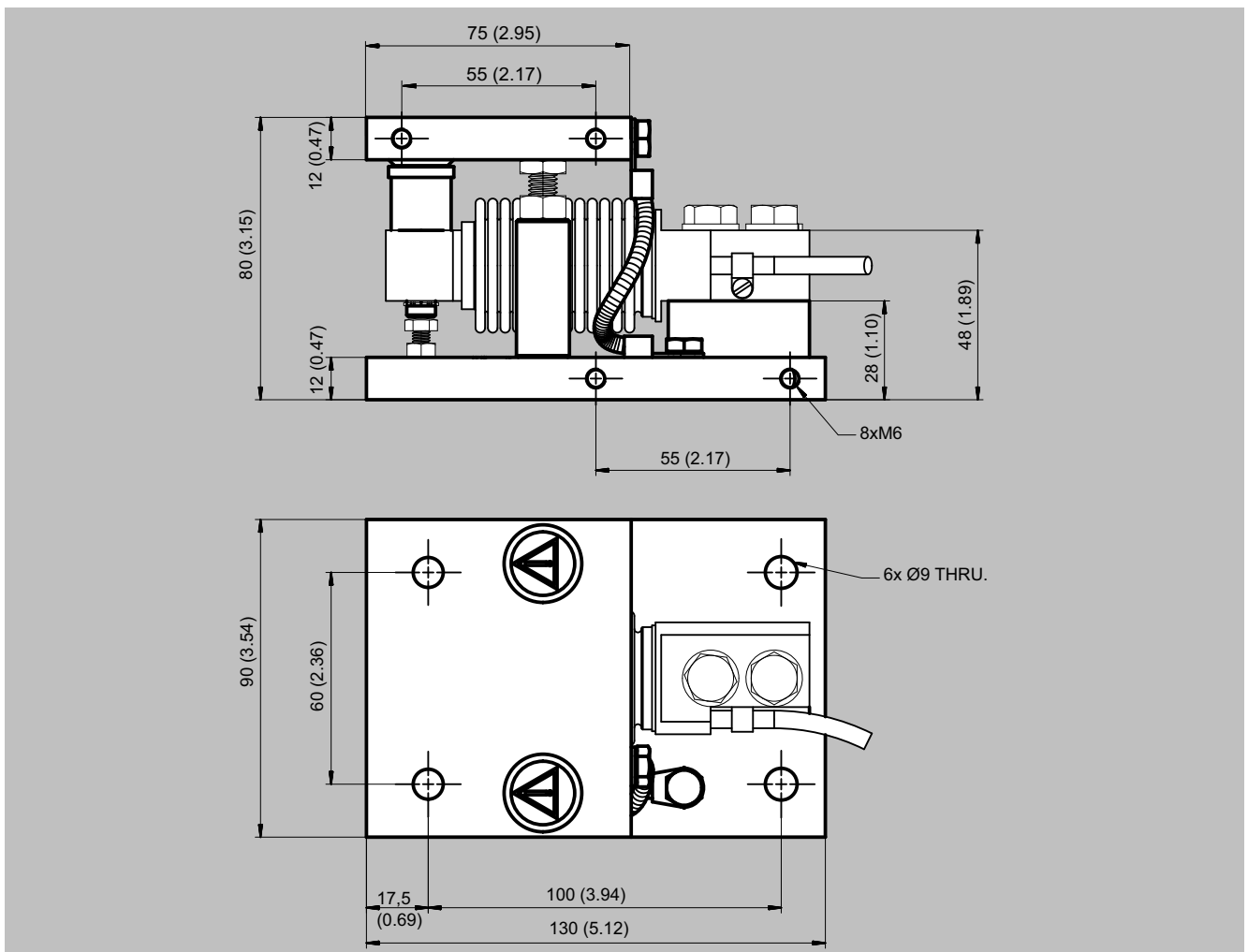

Mounting unit for SIWAREX WL230 BB-S SA load cells, 10 ... 200 kg (22.05 ... 440.92 lb), dimensions in mm (inch)

Dimensional drawings (Continued)

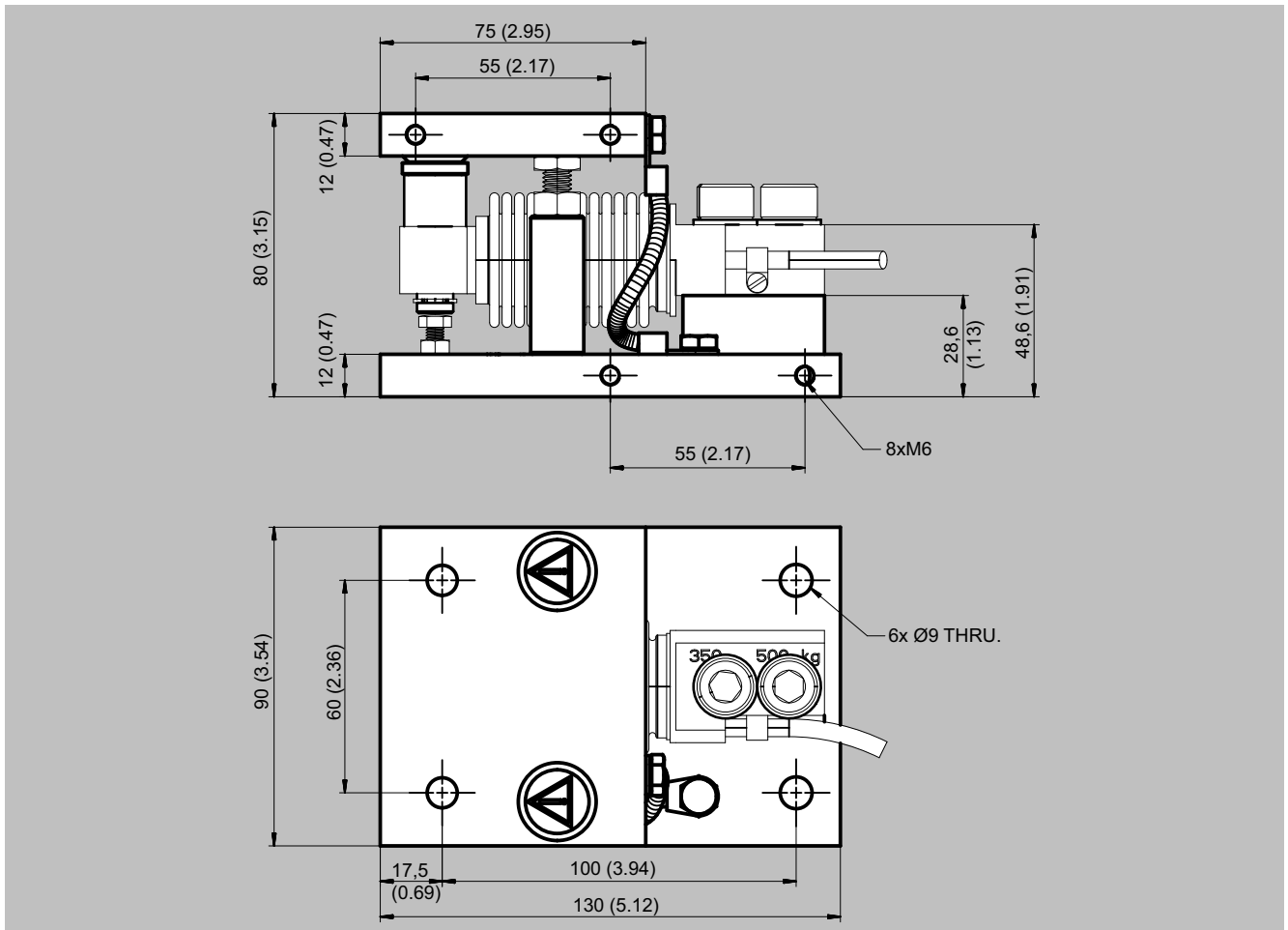

Mounting unit for SIWAREX WL230 BB-S SA load cells, 350 and 500 kg (771.62 and 1 102.31 lb), dimensions in mm (inch)

Load Cells

Bending beam load cells

SIWAREX WL230 BB-S SA Mounting unit

Dimensional drawings (Continued)

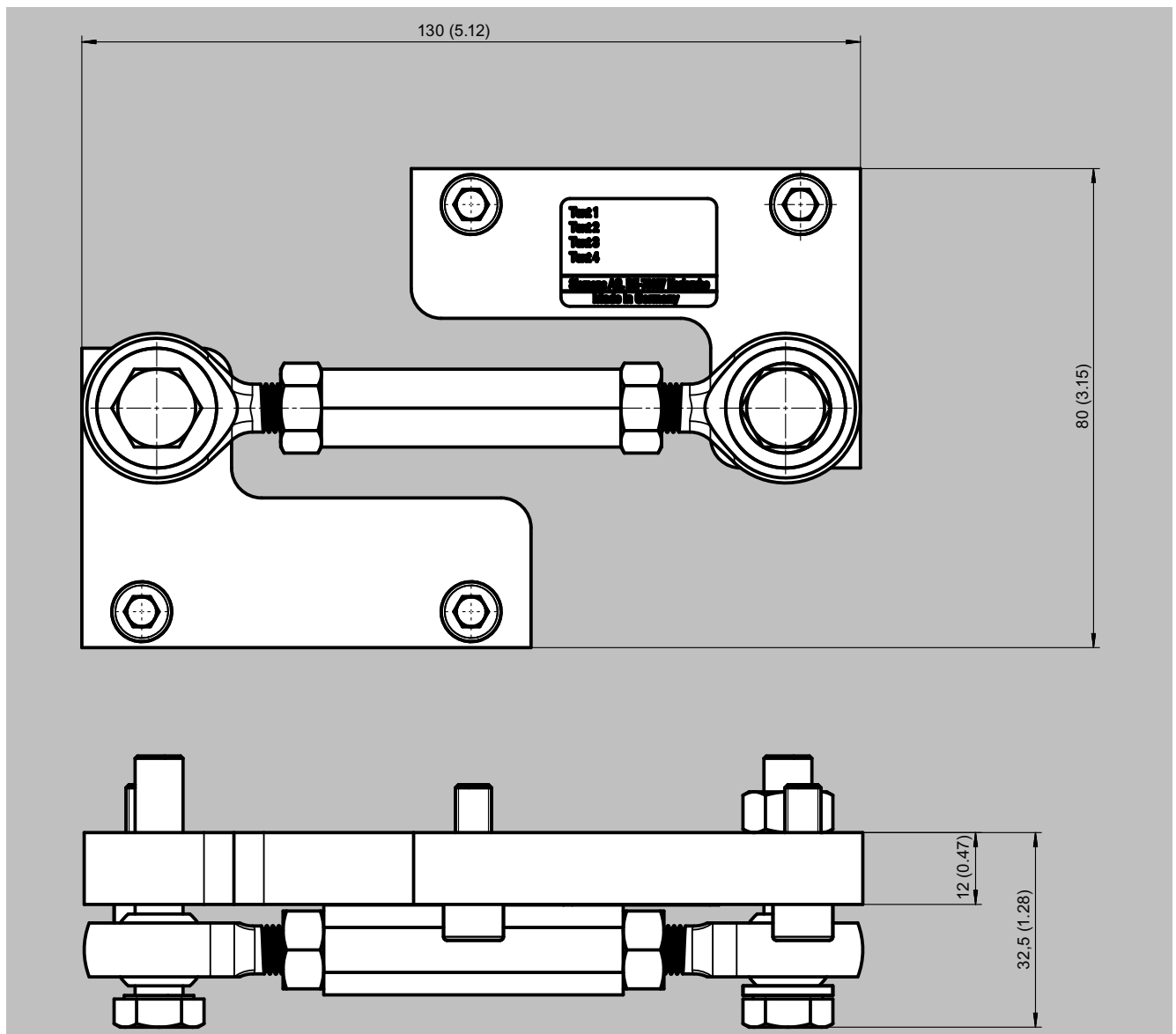

Guide element for SIWAREX WL230 BB-S SA load cells, 10 ... 500 kg (22.01 ... 1 102.31 lb), dimensions in mm (inch)

Overview



Elastomer bearing for load cells of the SIWAREX WL230 BB-S SA, 10 ... 200 kg (22.05 ... 440.93 lb) series

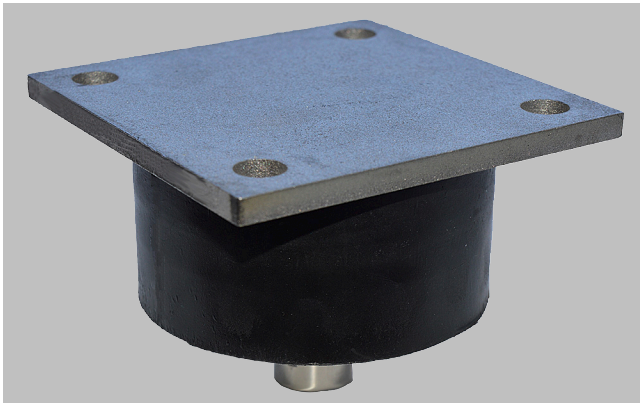

Elastomer bearing for load cells of the SIWAREX WL230 BB-S SA, 350 und 500 kg (771.62 and 1 102.31 lb) series

The self-centering elastomer bearing for load cells of the SIWAREX WL230 BB-S SA series is the ideal load introduction element for scales without guide elements. It serves to damp vibrations and shocks.

Design

Elastomer bearings are rubber-metal composites made of neoprene and stainless steel. They ensure large spring excursions (i.e. a high degree of damping) despite small dimensions.

If the load bearing implement is displaced by more than 4 mm (0.16 inch) in the horizontal direction, measures for restricting sideways play (e.g. in the form of guide elements) must be provided in the construction of the load bearing implement.

In combination with the base plate and integral overload protection, it is ensured that the load cell is not damaged by static overloading with vertical forces of up to 5 kN.

The load cell and the base plate are not included in the scope of delivery of the elastomer bearing.

Selection and ordering data

Elastomer bearings For load cells of the SIWAREX WL230 BB-S SA series		Article No.
Material: Neoprene, stainless steel EN 1.4301		
For load cells with a rated load of ¹⁾²⁾		
• 10 ... 200 kg (22.05 ... 440.92 lb)		7MH4133-3DE11
• 350, 500 kg (771.61, 1 102.31 lb)		7MH5706-0PC00

¹⁾ The load cell is not included in the scope of delivery.

²⁾ It is highly recommendable to use a grounding cable (7MH3701-1AA1) in order to protect the load cell.

Load Cells

Bending beam load cells

SIWAREX WL230 BB-S SA Elastomer bearing

Technical specifications

Elastomer bearings for load cells of the SIWAREX WL230 BB-S SA series

Rated load	10 kg (22.05 lb)	20 kg (44.09 lb)	50 kg (110.23 lb)	100 kg (220.46 lb)	200 kg (440.93 lb)	350 kg (771.62 lb)	500 kg (1 102.31 lb)
Max. permissible lateral deflection	± 4 mm (0.16 inch)	± 4 mm (0.16 inch)	± 4 mm (0.16 inch)	± 4 mm (0.16 inch)	± 4 mm (0.16 inch)	± 4 mm (0.16 inch)	± 4 mm (0.16 inch)
Vertical rigidity	0.89 kN/mm	0.89 kN/mm	0.89 kN/mm	0.89 kN/mm	0.89 kN/mm	3.8 kN/mm	3.8 kN/mm
Horizontal rigidity	0.16 kN/mm	0.16 kN/mm	0.16 kN/mm	0.16 kN/mm	0.16 kN/mm	0.1 kN/mm	0.1 kN/mm
Spring compression at rated load	0.10 mm	0.20 mm	0.50 mm	1.10 mm	2.10 mm	0.68 mm	1.28 mm

Dimensional drawings

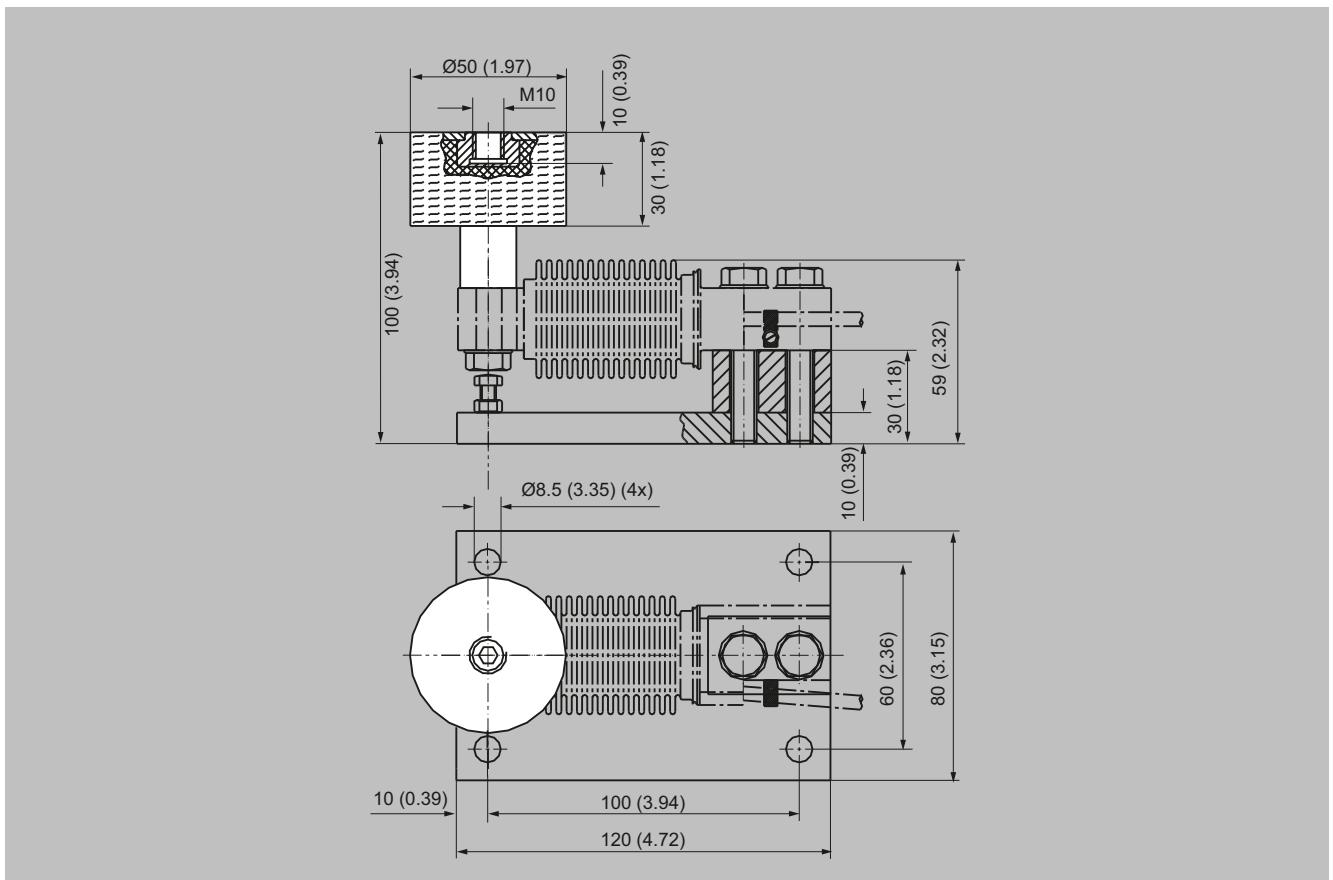

Elastomer bearings for SIWAREX WL230 BB S SA load cells, 10 ... 200 kg (22.05 lb ... 440.92 lb), dimensions in mm (inch)

Overview



The base plate with integral overload protection for load cells of the SIWAREX WL230 BB-S SA series ensures easy, correct installation of the load cell.

Design

The integrated overload protection ensures that the load cell is not damaged by static overloading with vertical forces of up to 5 kN. The load cells can be installed on the base plate and aligned even before final installation of the scales. This ensures that the permissible spring excursion of the load cell is precisely set, up to contact with the overload protection.

The load cell is not included in the scope of delivery of the base plate with overload protection.

Selection and ordering data

	Article No.
Base plate with overload protection	
For load cells of the SIWAREX WL230 BB-S SA series	
Material: Stainless steel EN 1.4301	
For load cells with a rated load of ¹⁾²⁾	
• 10 ... 200 kg (22.05 ... 440.92 lb)	7MH4133-3DG11
• 350, 500 kg (771.62, 1 102.31 lb)	7MH4133-3KG11

¹⁾ The load cell is not included in the scope of delivery.

²⁾ It is highly recommendable to use a grounding cable (7MH3701-1AA1) in order to protect the load cell.

Dimensional drawings

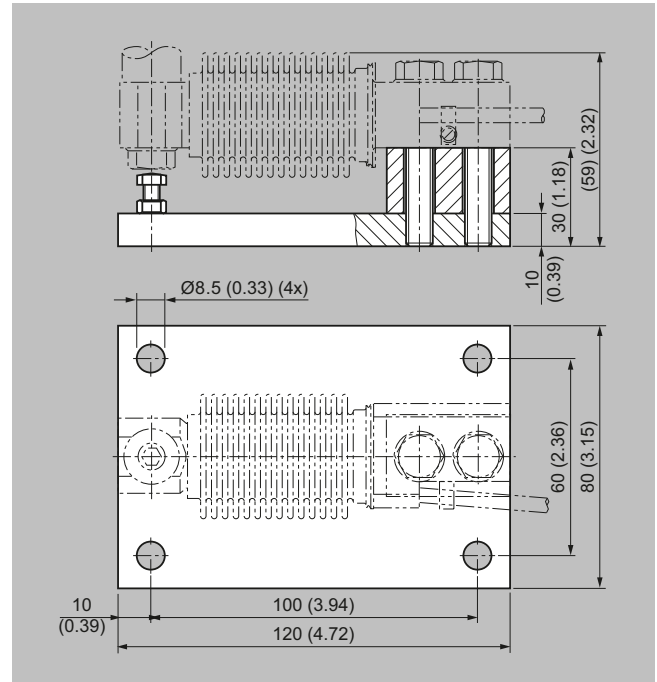

Elastomer bearing and base plate with overload protection for SIWAREX WL230 BB-S SA load cells, 10 ... 200 kg (22.05 ... 440.92 lb), dimensions in mm (inch)