









## Swivel modules DSMI-B, with integrated angular displacement encoder

**FESTO**



Product range overview

Function	Type	Description
Drives	<b>Rodless</b>	
	DDLI	<ul style="list-style-type: none"> <li>• Without guide</li> <li>• With displacement encoder for contactless measurement</li> <li>• Based on linear drive DGC-K</li> <li>• Supply ports on the end face</li> <li>• System product for handling and assembly technology</li> </ul>
		
	DGCI	<ul style="list-style-type: none"> <li>• With guide</li> <li>• With displacement encoder for contactless measurement</li> <li>• Based on linear drive DGC</li> <li>• Supply ports optionally on the end face or at the front</li> <li>• System product for handling and assembly technology</li> </ul>
		
	<b>With piston rod</b>	
	DNCI	<ul style="list-style-type: none"> <li>• With displacement encoder for contactless measurement</li> <li>• Range of piston rod variants</li> <li>• Standards-based cylinder to ISO 15552</li> </ul> 
		
	DDPC	<ul style="list-style-type: none"> <li>• With displacement encoder for contactless measurement</li> <li>• Range of piston rod variants</li> <li>• Standards-based cylinder to ISO 15552</li> </ul> 
		
DNC/DSBC	<ul style="list-style-type: none"> <li>• With attached potentiometer MLO-LWG</li> <li>• Range of piston rod variants</li> <li>• Standards-based cylinder to ISO 15552</li> </ul> 	
		
Semi-rotary drive	<b>Semi-rotary drive</b>	
		<ul style="list-style-type: none"> <li>• Based on semi-rotary drive DSM</li> <li>• Integrated rotary potentiometer</li> <li>• Compact design</li> <li>• Wide range of mounting options</li> </ul>

## Product range overview

Piston $\varnothing$	Stroke/swivel angle [mm/°]	Suitable			As a measuring cylinder
		For positioning with		For end-position controller	
		CPX-CMAX	CPX-CMPX	SPC11	
<b>Rodless</b>					
25, 32, 40, 63	100, 160, 225, 300, 360, 450, 500, 600, 750, 850, 1000, 1250, 1500, 1750, 2000	■	■	■	■
18, 25, 32, 40, 63	100, 160, 225, 300, 360, 450, 500, 600, 750, 850, 1000, 1250, 1500, 1750, 2000	■	■	■	■
<b>With piston rod</b>					
32, 40, 50, 63	10 ... 2000	–	–	–	■
	100 ... 750	■	■	■	–
80, 100	10 ... 2000	–	–	–	■
	100 ... 750	■	■	■	–
32, 40, 50, 63, 80	100, 150, 225, 300, 360, 450, 600, 750	■	■	■	■
<b>Semi-rotary drive</b>					
40	270	■	■	■	■

### Key features

#### Servo-pneumatic drive technology

Positioning and Soft Stop applications as an integral component of the valve terminal CPX – the modular peripheral system for decentralised automation tasks. The modular design means that valves, digital inputs and outputs, positioning modules and end-position controllers, as appropriate for the application, can be combined in almost any way on the CPX terminal.

#### Advantages:

- Pneumatics and electrics – control and positioning on one platform
- Innovative positioning technology – piston rod drives, rodless drives, rotary drives
- Actuation via fieldbus
- Remote maintenance, remote diagnostics, web server, SMS and e-mail alerts are all possible via TCP/IP
- Modules can be quickly exchanged and expanded without altering the wiring

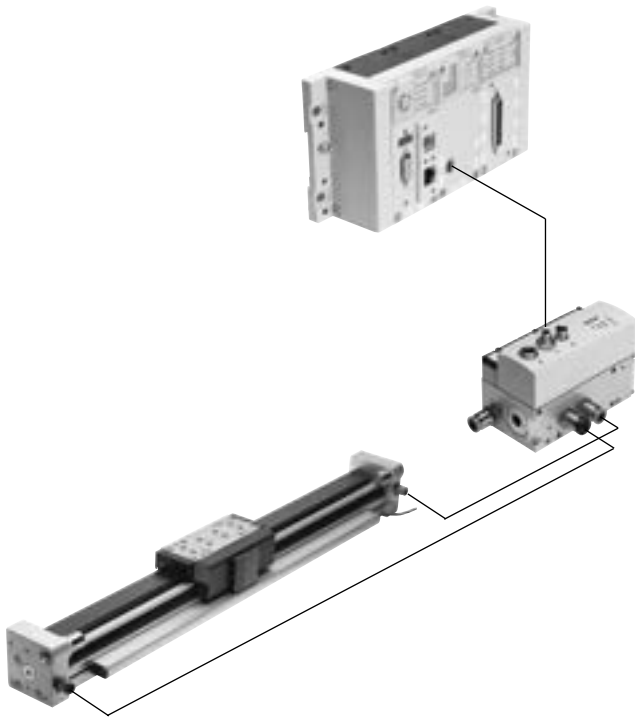

#### Axis controller CPX-CMAX



#### Free choice:

Position and force control, directly actuated or selected from one of 128 configurable position sets.

If you are looking for something more: The configurable record sequencing function enables simple functional sequences to be realised with the axis controller CPX-CMAX.

Everything is recognisable: the auto-identification function identifies each participant with its device data on the controller CPX-CMAX.

#### Also included:

Actuation of a brake or clamping unit via the proportional directional control valve VPWP is also part of the scope of performance of the controller CPX-CMAX.

Up to 8 modules (max. 8 axes) can be operated in parallel and independently of each other.

Commissioning via FCT (Festo configuration software) or via fieldbus: no programming, only configuration.

#### Advantages:

- Greater flexibility
- OEM friendly – commissioning also via fieldbus
- Easy installation and fast commissioning
- Cost-effective
- You program the system in your PLC environment

## Key features

## End-position controllers CPX-CMPX

Datasheets → Internet: [cpx-cmpx](#)

Fast travel between the mechanical end stops of the cylinder, stopping gently and without impact in the end position.  
 Fast commissioning via control panel, fieldbus or handheld unit.  
 Improved control of standstills.  
 Actuation of a brake or clamping unit via the proportional directional control valve VPWP is an integral part of the controller CMPX.

Depending on the fieldbus chosen, up to 9 end-position controllers can be actuated on the CPX terminal.  
 All system data can be read and written via the fieldbus, including, for example, the mid-positions.

- Advantages:
- Greater flexibility
  - OEM friendly – commissioning also via fieldbus
  - Easy installation and fast commissioning
  - Cost-effective
    - Up to 30% faster cycle rates
    - Significantly reduced system vibration
  - Improved work ergonomics thanks to significantly reduced noise level
  - The extended diagnostics help to reduce the service time of the machine

## Proportional directional control valve VPWP

Datasheets → Internet: [vpwp](#)

The 5/3-way proportional directional control valve for applications with Soft Stop and pneumatic positioning.  
 Fully digitalised – with integrated pressure sensors, with new diagnostic functions.  
 In sizes 4, 6, 8 and 10.  
 Flow rates of 350, 700, 1400 and 2000 l/min.

With switching output for controlling a brake.  
 Colour-coded supply ports.  
 Pre-assembled cables guarantee error-free and fast connection to the controllers CPX-CMPX and CPX-CMAX.

- Advantages:
- Easy installation and fast commissioning
  - Reduction of system downtimes thanks to the new diagnostic options
  - With switching output for controlling a brake/clamping unit

## Measuring module CPX-CMIX

Datasheets → Internet: [cpx-cmix](#)

Fully digital data acquisition and transmission means that pneumatic cylinders can be used as sensors. With very high repetition accuracy and incorporating both analogue and digital measuring sensors.

Suitable for the linear drive DGCI with displacement encoder for measuring absolute values, for the piston rod drive DNCI/DDPC with incremental displacement encoder or even for a potentiometer type MLO.

- Advantages:
- All process steps can be documented, which improves quality
  - An adjustable contact force (via pressure regulator) increases the precision of the "displacement sensor"
  - With displacement encoders for measuring absolute values, the actual position is immediately available after the system is switched on

## Drive options

### System with linear drive DDLI, DGCI

Datasheets → Internet: ddli or dgci

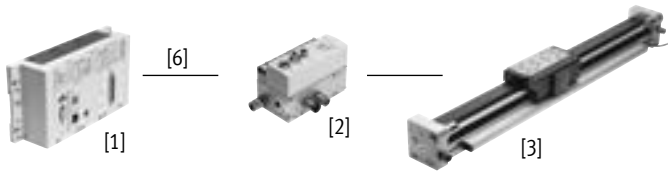

- [1] Controller module CPX-CMPX or CPX-CMAX
- [2] Proportional directional control valve VPWP
- [3] Linear drive DDLI, DGCI with displacement encoder
- [6] Connecting cable KVI-CP-3...

- Pneumatic rodless linear drive with displacement encoder, with or without recirculating ball bearing guide
- Displacement encoder with absolute and contactless measurement
- Diameter:
  - With DGCI: 18 ... 63 mm
  - With DDLI: 25 ... 63 mm
- Stroke: 100 ... 2000 mm in fixed lengths
- Application areas: Soft Stop and pneumatic positioning
- Loads from 1 ... 180 kg
- No sensor interface required

#### Advantages:

- Complete drive unit
- DDLI for easy connection to customer's guide system
- Excellent running characteristics
- For fast and accurate positioning up to ±0.2 mm (only with axis controller CPX-CMAX)

### System with standards-based cylinder DNCI, DDPC

Datasheets → Internet: dnci

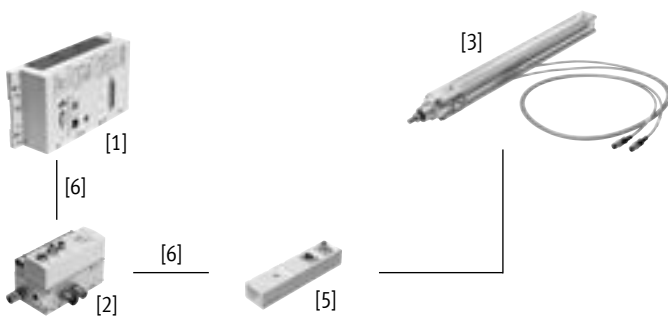

- [1] Controller module CPX-CMPX or CPX-CMAX
- [2] Proportional directional control valve VPWP
- [3] Standards-based cylinder DNCI, DDPC with displacement encoder
- [5] Sensor interface CASM-S-D3-R7
- [6] Connecting cable KVI-CP-3...

- Standards-based cylinder with integrated displacement encoder, conforms to DIN ISO 6432, VDMA 24 562, NF E 49 003.1 and Uni 10 290
- Displacement encoder with contactless and incremental measurement
- Diameter: 32 ... 100 mm
- Stroke: 100 ... 750 mm
- Application areas: Soft Stop and pneumatic positioning
- Loads from 3 ... 450 kg and the corresponding sensor interface CASM-S-D3-R7
- Pre-assembled cables guarantee error-free and fast electrical connection

#### Advantages:

- Compact drive unit
- Universal applications
- Also with guide unit
- For fast and accurate positioning up to ±0.5 mm (only with axis controller CPX-CMAX)

## Drive options

## System with semi-rotary drive DSMI

Datasheets → Internet: dsmi

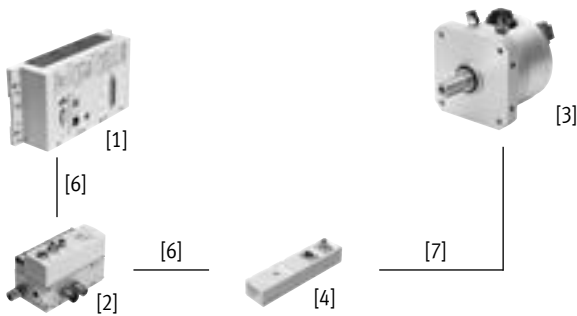

- [1] Controller module CPX-CMPX or CPX-CMAX
- [2] Proportional directional control valve VPWP
- [3] Semi-rotary drive DSMI with displacement encoder
- [4] Sensor interface CASM-S-D2-R3
- [6] Connecting cable KVI-CP-3-...
- [7] Connecting cable NEBC-P1W4-K-0.3-N-M12G5

- Swivel drive DSMI with integrated displacement encoder
- Identical design to pneumatic semi-rotary drive DSM
- Absolute displacement encoder based on a potentiometer
- Swivel range from 0 ... 270°
- Size: 40
- Max. torque: 20 Nm
- Application areas: Soft Stop and pneumatic positioning
- Mass moments of inertia of 60 ... 1200 kgcm<sup>2</sup> and the corresponding sensor interface CASM-S-D2-R3
- Pre-assembled cables guarantee error-free and fast connection to the proportional directional control valve VPWP

## Advantages:

- Complete drive unit, compact, can be used immediately
- High angular acceleration
- With adjustable fixed stops
- For fast and accurate positioning down to ±0.2° (only with axis controller CPX-CMAX)

## System with potentiometer

Datasheets → Internet: casm

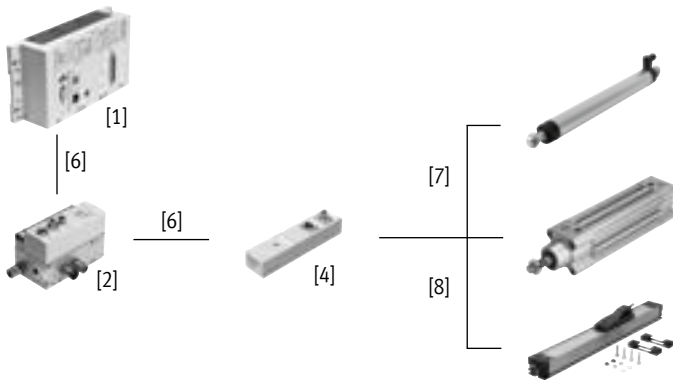

- [1] Controller module CPX-CMPX or CPX-CMAX
- [2] Proportional directional control valve VPWP
- [4] Sensor interface CASM-S-D2-R3
- [6] Connecting cable KVI-CP-3-...
- [7] Connecting cable NEBC-P1W4-K-0.3-N-M12G5
- [8] Connecting cable NEBC-A1W3-K-0.4-N-M12G5

- Attachable potentiometers with absolute measurement, with high degree of protection
- With connecting rod or moment compensator
- Measuring range:  
Connecting rod: 100 ... 750 mm  
Moment compensator: 225 ... 2000 mm
- Pre-assembled cables guarantee error-free and fast connection to the sensor interface CASM
- Application areas: Soft Stop and pneumatic positioning with cylinder diameters of 25 ... 80 mm
- Loads from 1 ... 300 kg

## Advantages:

- Easy installation and fast commissioning
- Cost-effective
- Can also be used in harsh operating conditions
- Variety of drives: CPX-CMPX and CPX-CMAX also support cylinders with external displacement encoder

## Drive options

System components for Soft Stop systems with end-position controller CPX-CMPX						
	Linear drive	Standards-based cylinder	Semi-rotary drive	Displacement encoder		→ Page/ Internet
	DDL/DGCI	DNCI, DDPC	DSMI	MLO-LWG/-TLF	MME-MTS	
End-position controller CPX-CMPX	■	■	■	■	■	cmpx
Proportional directional control valve VPWP	■	■	■	■	■	vpwp
Sensor interface CASM-S-D2-R3	–	–	■	■	–	casm
Sensor interface CASM-S-D3-R7	–	■	–	–	–	casm
Connecting cable KVI-CP-3-...	■	■	■	■	■	kvi
Connecting cable NEBC-P1W4-...	–	–	■	■ / –	–	nebc
Connecting cable NEBC-A1W3-...	–	–	–	– / ■	–	nebc
Connecting cable NEBP-M16W6-...	–	–	–	–	■	vpwp

System components for pneumatic positioning systems with axis controller CPX-CMAX						
	Linear drive	Standards-based cylinder	Semi-rotary drive	Displacement encoder		→ Page/ Internet
	DDL/DGCI	DNCI, DDPC	DSMI	MLO-LWG/-TLF	MME-MTS	
Axis controller CPX-CMAX	■	■	■	■	■	cmax
Proportional directional control valve VPWP	■	■	■	■	■	vpwp
Sensor interface CASM-S-D2-R3	–	–	■	■	–	casm
Sensor interface CASM-S-D3-R7	–	■	–	–	–	casm
Connecting cable KVI-CP-3-...	■	■	■	■	■	kvi
Connecting cable NEBC-P1W4-...	–	–	■	■ / –	–	nebc
Connecting cable NEBC-A1W3-...	–	–	–	– / ■	–	nebc
Connecting cable NEBP-M16W6-...	–	–	–	–	■	vpwp

System components for measuring cylinders with measuring module CPX-CMIX						
	Linear drive	Standards-based cylinder	Semi-rotary drive	Displacement encoder		→ Page/ Internet
	DDL/DGCI	DNCI, DDPC	DSMI	MLO-LWG/-TLF	MME-MTS	
Measuring module CPX-CMIX-M1-1	■	■	■	■	■	cmix
Sensor interface CASM-S-D2-R3	–	–	■	■	–	casm
Sensor interface CASM-S-D3-R7	–	■	–	–	–	casm
Connecting cable KVI-CP-3-...	(■) <sup>1)</sup>	■	■	■	(■)	kvi
Connecting cable NEBC-P1W4-...	–	–	■	■ / –	–	nebc
Connecting cable NEBC-A1W3-...	–	–	–	– / ■	–	nebc
Connecting cable NEBP-M16W6-...	–	–	–	–	■	vpwp

1) As an extension



## Key features

### At a glance

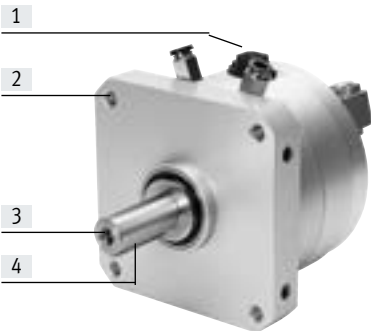

- [1] Connector plug for displacement encoder
- [2] Wide range of integrated mounting options
- [3] Option for mounting on the drive shaft by the customer
- [4] Feather key

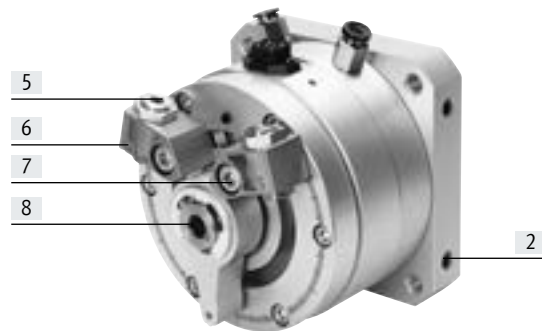

- [7] Fixed stop can be set at any point within the swivel angle
- [8] Manual operation via internal hexagon socket in the drive shaft. A female thread is already integrated for attaching an additional drive shaft by the customer.

### Mounting options

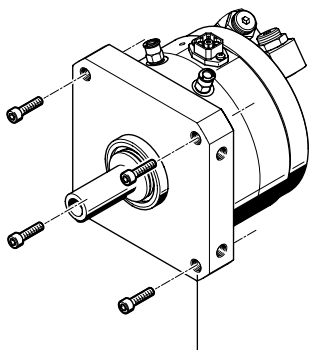

Threaded through-hole

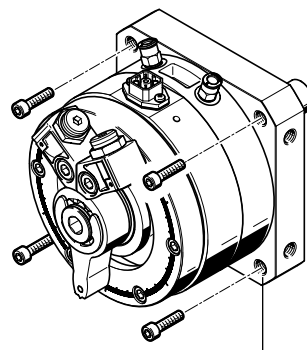

Threaded through-hole

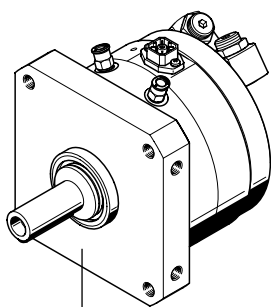

Centring collar

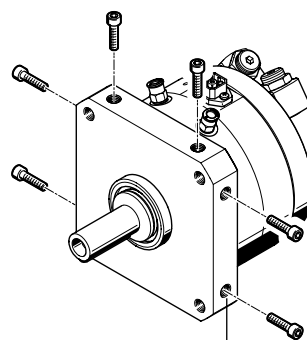

Basic thread

## Swivel modules DSMI-B, with integrated angular displacement encoder

### Type codes

001	Series
<b>DSMI</b>	Semi-rotary drive with displacement encoder, double-acting

002	Size [mm]
<b>25</b>	25
<b>40</b>	40

003	Nominal swivel angle [°]
<b>270</b>	270

004	Position sensing
<b>A</b>	For proximity sensor

005	Variant
<b>B</b>	B-series

## Peripherals overview

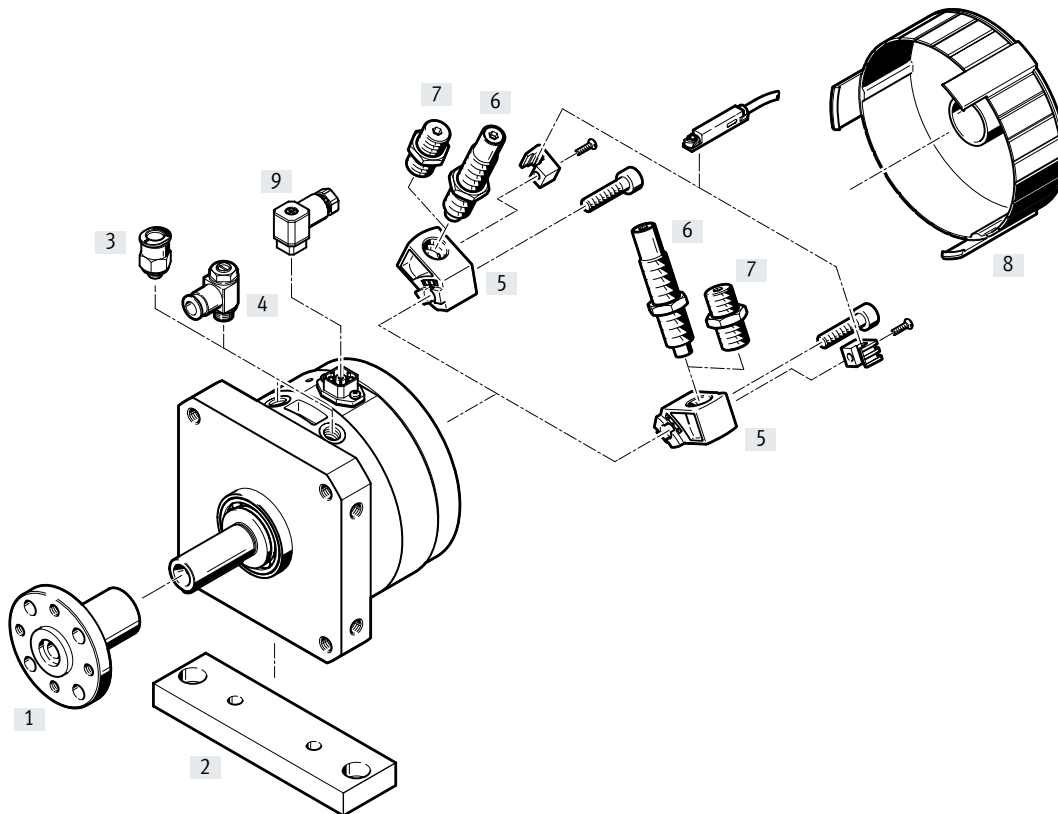

## Accessories

	Description	→ Page/Internet
[1]	Push-on flange FWSR	For mounting attachments 17
[2]	Mounting plate HSM	Adapter plate for mounting the drive 17
[3]	Push-in fitting QS	For connecting tubing with standard O.D. (push-in fittings are included in the scope of delivery of the drive) qs
[4]	One-way flow control valve GRLA	For regulating speed (is recommended when using the DSMI as a measuring cylinder) 19
[5]	Cushioning mount DSM-B	<ul style="list-style-type: none"> <li>• For elastic cushioning components</li> <li>• For shock absorbers</li> <li>• As a mechanical stop in Soft Stop applications</li> </ul> 18
[6]	Shock absorber DYSC	Self-adjusting shock absorbers with fixed stop (is recommended when using the DSMI as a measuring cylinder) 18
[7]	Cushioning kit DSM-...-P-B	Elastic cushioning components with fixed stop 18
[8]	Cover cap AKM	Reduces the risk of injury in the swivel range of the stop lever 18
[9]	Plug socket SD	For connecting the displacement encoder 19

# Swivel modules DSMI-B, with integrated angular displacement encoder

## Datasheet

-  Size  
40
-  Torque  
20 Nm



General technical data		
Size		40
Design		Vane
		Drive shaft, fitted with ball bearings
Operating mode		Double-acting
Type of mounting		Via female thread
Position sensing		Via integrated angular displacement encoder
		Via proximity sensor <sup>1)</sup>
Measuring principle (angular displacement encoder)		Analogue with conductive plastic potentiometer
Min. travel speed	[°/s]	50
Max. travel speed	[°/s]	2 000
Max. swivel angle <sup>2)</sup>	[°]	272
Setting range of swivel angle	[°]	0 ... 270
Pneumatic connection		G1/8
Push-in fitting used		QS-G1/8-8-I
Compressed air tubing O.D.	[mm]	8

- 1) Not included in the scope of delivery, can be ordered as an option  
 2) Note stroke reduction in combination with axis controller CPX-CMAX

Operating and environmental conditions		
Size		40
Operating pressure	[MPa]	0.2 ... 1
	[bar]	2 ... 10
	[psi]	29 ... 145
Operating pressure <sup>1)</sup>	[MPa]	0.4 ... 0.8
	[bar]	4 ... 8
	[psi]	58 ... 116
Operating medium <sup>2)</sup>		Compressed air to ISO 8573-1:2010 [6:4:4]
Note on the operating/pilot medium		Lubricated operation not possible Pressure dew point 10 °C below ambient/medium temperature
Ambient temperature <sup>3)</sup>	[°C]	-10 ... +60
Vibration resistance to DIN/IEC 68, Part 2-6		Severity level 2
Continuous shock resistance to DIN/IEC 68, Part 2 - 82		Severity level 2
CE marking (see declaration of conformity) <sup>4)</sup>		To EU EMC Directive
		To EU RoHS Directive
UKCA marking (see declaration of conformity) <sup>4)</sup>		To UK instructions for EMC
		To UK RoHS instructions
Corrosion resistance class CRC <sup>5)</sup>		1

- 1) Only applies to applications with end-position controller CPX-CMPX, SPC11 and axis controller CPX-CMAX  
 2) The proportional directional control valve VPWP, MPYE used requires these characteristic values  
 3) Note operating range of proximity switches  
 4) For information about the area of use, see the EC declaration of conformity at: [www.festo.com/sp](http://www.festo.com/sp) → Certificates.  
 If the devices are subject to usage restrictions in residential, commercial or light-industrial environments, further measures for the reduction of the emitted interference may be necessary.  
 5) Corrosion resistance class CRC 1 to Festo standard FN 940070  
 Low corrosion stress. Dry internal application or transport and storage protection. Also applies to parts behind covers, in the non-visible interior area, or parts that are covered in the application (e.g. drive trunnions).

Weight		
Size		40
DSMI	[g]	3950

## Datasheet

<b>Torque [Nm]</b>	
Size	40
Torque <sup>1)</sup>	20

1) Theoretical values, calculated at 0.6 MPa (6 bar, 87 psi)

<b>Permissible forces on the drive shaft</b>	
Size	40
Max. radial force	[N] 350
Max. axial force	[N] 120
Max. swivel frequency <sup>1)</sup>	[Hz] 2

1) At max. permissible mass moment of inertia, operating pressure of 0.6 MPa (6 bar, 87 psi) and a swivel angle of 270°



### Note

Additional technical data

→ Internet: dsm

<b>Positioning characteristics with axis controller CPX-CMAX</b>	
Size	40
Mounting position	Any
Resolution	[°] 0.1
Repetition accuracy	[°] ≤ ±0.3
Min. mass moment of inertia, horizontal <sup>1)</sup>	[kgm <sup>2</sup> ] 60 x 10 <sup>-4</sup>
Max. mass moment of inertia, horizontal <sup>1)</sup>	[kgm <sup>2</sup> ] 1200 x 10 <sup>-4</sup>
Min. mass moment of inertia, vertical <sup>2)</sup>	[kgm <sup>2</sup> ] 60 x 10 <sup>-4</sup>
Max. mass moment of inertia, vertical <sup>2)</sup>	[kgm <sup>2</sup> ] 1200 x 10 <sup>-4</sup>
Min. travel speed	[°/s] 50
Max. travel speed	[°/s] 2000
Typical positioning time, long stroke <sup>3)</sup>	[s] 0.30/0.55
Typical positioning time, short stroke <sup>4)</sup>	[s] 0.25/0.25
Min. positioning stroke	[°] 5
Max. swivel stroke <sup>5)</sup>	[°] 260
<b>Recommended proportional directional control valve</b>	
For CPX-CMAX	VPWP-4-L-5-Q8-10-E-F

- 1) Must not change during the movement, but may be outside the centre of gravity
- 2) Must not change during the movement, must act at the centre of gravity
- 3) At 0.6 MPa (6 bar, 87 psi), vertical mounting position, 260° positioning angle at min./max. mass moment of inertia
- 4) At 0.6 MPa (6 bar, 87 psi), vertical mounting position, 15° positioning angle at min./max. mass moment of inertia
- 5) A stroke reduction of 5° on both sides must be observed

## Datasheet

**Positioning characteristics with Soft Stop end-position controller CPX-CMPX, SPC11**

Size	40	
Mounting position	Horizontal	
End-position repetition accuracy <sup>1)</sup>	[°]	< ±0.2
Intermediate-position repetition accuracy	[°]	±2
Cushioning <sup>2)</sup>	Electronically controlled	
Min. mass moment of inertia, horizontal <sup>3)</sup>	[kgm <sup>2</sup> ]	60 x 10 <sup>-4</sup>
Max. mass moment of inertia, horizontal <sup>3)</sup>	[kgm <sup>2</sup> ]	1200 x 10 <sup>-4</sup>
Min. swivel stroke	[°]	15
<b>Recommended proportional directional control valve</b>		
For CPX-CMPX	VPWP-4-L-5-Q8-10-E-F	
For SPC11	MPYE-5-1/8-LF-010-B	

- 1) When using the DSMI stops
- 2) The cushioning pad on the stop lever must be removed for applications with Soft Stop. The stop lever must not swivel to the end stop at too great a speed as this could damage the swivel module
- 3) Must not change during the movement, but may be outside the centre of gravity

**Electrical data – Displacement encoder**

Size	40		
Output signal	Analogue		
Linearity error <sup>1)</sup>	[%]	< ±0.25	
Power supply <sup>2)</sup>	[V DC]	10	
Max. current consumption	[mA]	4	
Wiper current	Recommended	[µA]	< 1
	Maximum <sup>3)</sup>	[mA]	10
Connection resistance	[kΩ]	5	
Connection resistance tolerance	[%]	±20	
Degree of protection	IP65		
CE marking (see declaration of conformity)	To EU EMC Directive <sup>4)</sup>		
Electrical connection	4-pin plug, □ 16, DIN 45 322		

- 1) In relation to max. swivel angle
- 2) Stabilised power supply is recommended, max. 42 V DC permissible
- 3) Only permissible in the short term in the event of a fault
- 4) For information about the area of use, see the EC declaration of conformity at: [www.festo.com/sp](http://www.festo.com/sp) → Certificates.  
If the devices are subject to usage restrictions in residential, commercial or light-industrial environments, further measures for the reduction of the emitted interference may be necessary.

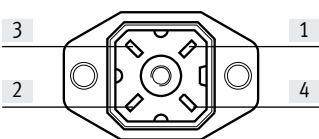
**Pin allocation for the plug**

Pin	Function
1	24 V Power supply
2	Sig Signal
3	0 V GND
4	PE Shield

## Datasheet

## Materials

## Sectional view

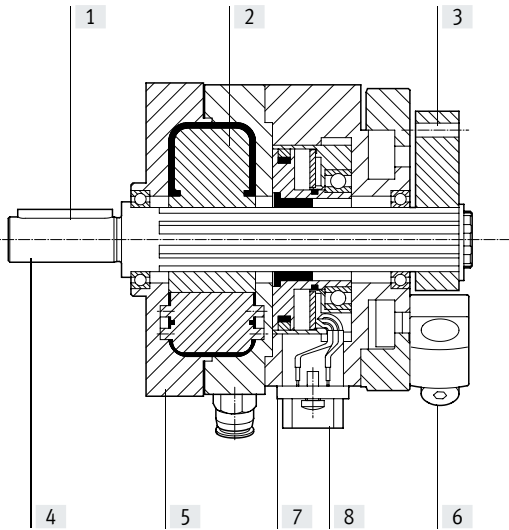

## Cylinder/displacement encoder

## Cylinders

[1]	Feather key	Steel
[2]	Vane	Glass fibre-reinforced plastic
[3]	Stop lever	Anodised wrought aluminium alloy
[4]	Drive shaft	Nickel-plated steel
[5]	Housing	Anodised wrought aluminium alloy
[6]	Fixed stop/screw	Steel
	Note on materials	RoHS-compliant PWIS conformity: VDMA24364-B2-L

## Displacement encoder

[7]	Coupling	Polyurethane
[8]	Housing	Anodised aluminium

Datasheet

Dimensions

Download CAD data → [www.festo.com](http://www.festo.com)

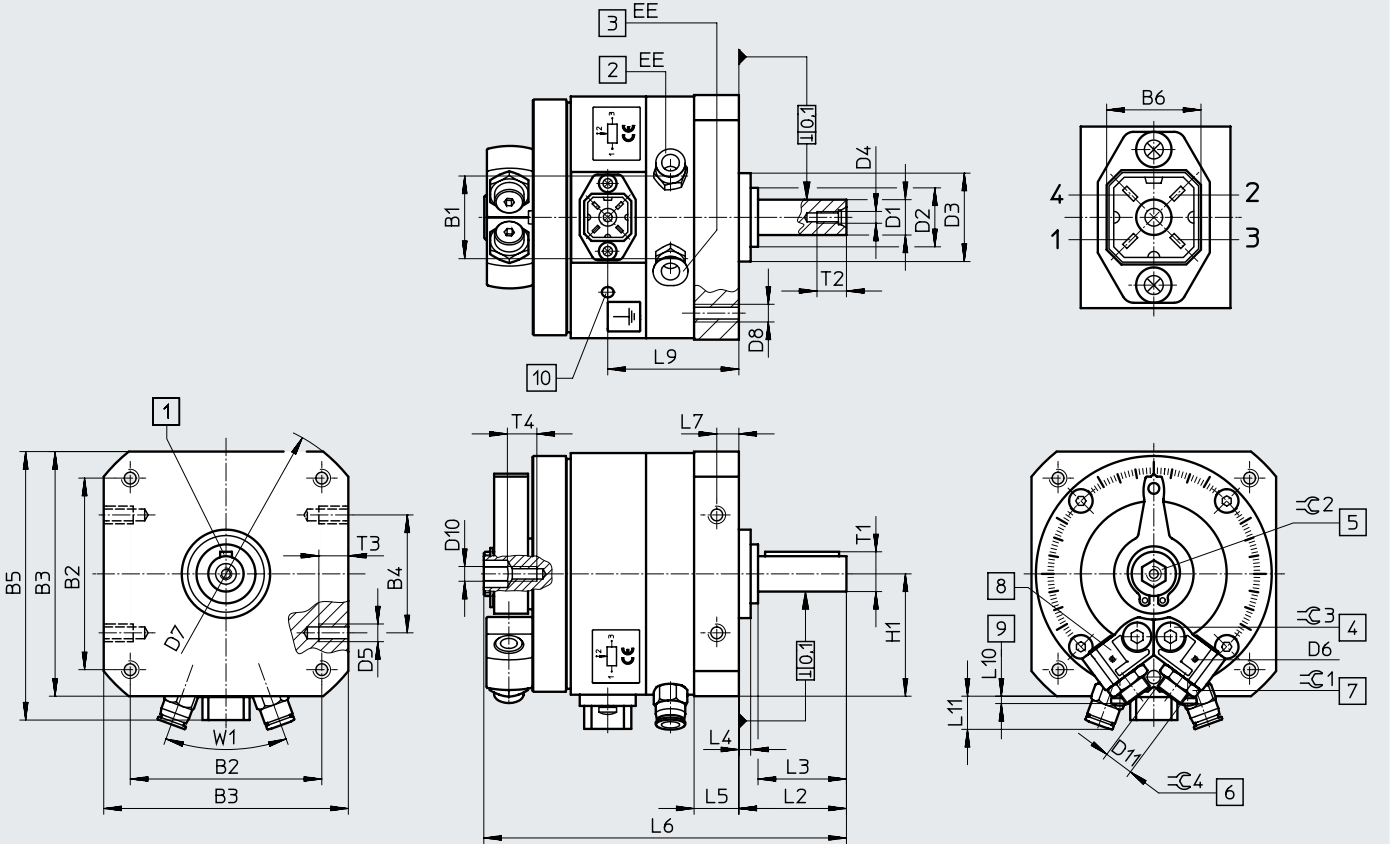

- [1] Feather key position at 0°
- [2] Blue releasing ring for supply port
- [3] Black releasing ring for supply port
- [4] Locking screw for clamping the stop
- [5] Manual override (internal hexagon)
- [6] End-position adjustment
- [7] Lock nut for end-position adjustment
- [8] Infinitely adjustable stops
- [9] Projection for end-position adjustment
- [10] Earth terminal for self-tapping M4x8 screw

Size	B1	B2	B3	B4	B5	B6	D1	D2	D3	D4	D5	D6	D7
[mm]	±0.5						g7 ∅	∅	f8 ∅				∅
40	43.8	105±0.3	130±0.5	80±0.3	139	16	20	36-0.4	52	M6	M10	M2	168±0.5

Size	D8	D10	D11	EE	H1	L2	L3	L4	L5	L6	L7	L9	L10
[mm]					±0.2	+0.6/-0.7	±0.2	±0.4	+0.2/-0.3			±0.2	±1
40	M10	M6	M16x1	G1/8	65	62	50	8	23.7	184±0.6	12	64.5	3.4

Size	L11	T1	T2	T3	T4	W1	∠ 1	∠ 2	∠ 3	∠ 4	Feather key to DIN 6885
[mm]	±2	max.	+2	±0.2		40°	19	10	8	5	A6x6x45
40	16	22.5	16	15	10	40°	19	10	8	5	A6x6x45



## Accessories

Ordering data	Size	Swivel angle [°]	Part no.	Type
	40	270	561691	DSMI-40-270-A-B

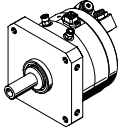
### Accessories

#### Push-on flange FWSR

Material:  
Anodised aluminium

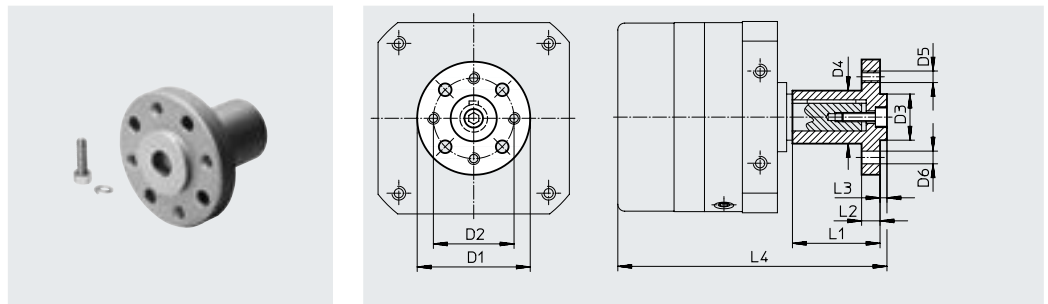

Dimensions and ordering data													
For size	B5	D11	D12 ∅	D13 ∅	D14 ∅	D15 ∅	L9	L10	L11	L12	Weight	Part no.	Type
[mm]			H13	g7							[g]		
40	54	M8	9	36	70	38	60	11	5	186.5	240	14656	FWSR-40

#### Mounting plate HSM

Material:  
Anodised aluminium

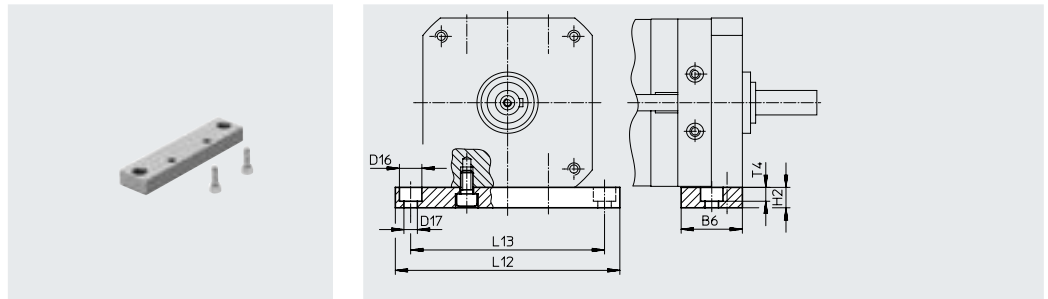

Dimensions and ordering data										
For size	B6	D16 ∅	D17 ∅	H2	L12	L13	T4	Weight	Part no.	Type
[mm]								[g]		
40	45	18	11	20	180	155	11	459	165575	HSM-40

# Swivel modules DSMI-B, with integrated angular displacement encoder

## Accessories

### Cover cap AKM

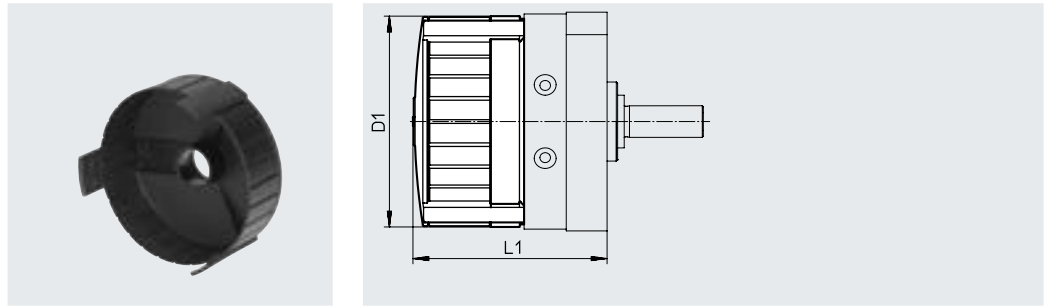

Material:  
Polyamide



#### Dimensions and ordering data

For size [mm]	D1 ∅	L1	Part no.	Type
40	130	135.5±1.5	549198	AKM-40

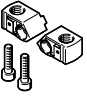
#### Ordering data

	For size	Description	Part no.	Type	PU <sup>1)</sup>
<b>Cushioning mount</b>					
	40	<ul style="list-style-type: none"> <li>• For elastic cushioning components</li> <li>• For shock absorbers</li> </ul>	547904	DSM-40-B	2
<b>Cushioning kit</b>					
	40	For cushioning mount DSMI-...-B	550660	DSM-40-P-B	2
<b>Shock absorber</b>					
	40	For cushioning mount DSMI-...-B	548014	DVSC-12-12-Y1F	1

1) Packaging unit.

## Accessories

Ordering data – One-way flow control valves						Datasheets → Internet: grla
	For size	Connection Thread	For tubing O.D.	Material	Part no.	Type
<b>For exhaust air</b>						
	40	G1/8	3	Metal design	193142	GRLA-1/8-QS-3-D
			4		193143	GRLA-1/8-QS-4-D
			6		193144	GRLA-1/8-QS-6-D
			8		193145	GRLA-1/8-QS-8-D

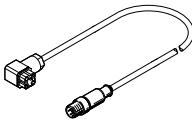
Ordering data – Connecting cable			
	Description	Part no.	Type
	Between sensor interface CASM and displacement encoder	549293	NEBC-P1W4-K-0.3-N-M12G5

Ordering data – Plug sockets			
	Description	Part no.	Type
	For displacement encoder connection	194332	SD-4-WD-7